

RESTRICTED

**PILOT TRAINING MANUAL**

**FOR THE LIBERATOR**

**B-24**

**Published for Headquarters, AAF**

**Office of Assistant Chief of Air Staff, Training**

**By Headquarters, AAF, Office of Flying Safety**

**Revised 1 May, 1945**

**ADDITIONAL COPIES OF THIS MANUAL MAY BE OBTAINED UPON REQUEST TO HQ AAF,  
OFFICE OF FLYING SAFETY, SAFETY EDUCATION DIVISION, WINSTON-SALEM 1, N. C.  
RESTRICTED**



## Foreword

THIS MANUAL is the text for your training as a B-24 pilot and airplane commander.

The Air Forces' most experienced training and supervisory personnel have collaborated to make it a complete exposition of what your pilot duties are, how each duty will be performed, and why it must be performed in the manner prescribed.

The techniques and procedures described in this book are standard and mandatory. In this respect the manual serves the dual purpose of a training checklist and a working handbook. Use it to make sure that you learn everything described herein. Use it to study and review the essential facts concerning everything taught. Such additional self-study and review will not only advance your training, but will alleviate the burden of your already overburdened instructors.

This training manual does not replace the Technical Orders for the airplane, which will always be your primary source of information concerning the B-24 so long as you fly it. This is essentially the textbook of the B-24. Used properly, it will enable you to utilize the pertinent Technical Orders to even greater advantage.

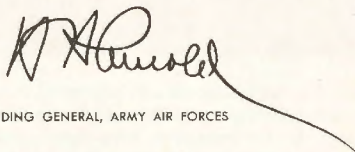

COMMANDING GENERAL, ARMY AIR FORCES

RESTRICTED



## THE B-24 IN COMBAT

The B-24 is used today all over the world. It is the workhorse of every air force. Its formations are roaring over mountains, seas, desert, and arctic, laden with tons of destruction for the enemy.

Liberators are being used more and more in combat for one conclusive reason: The B-24 has everything—speed, climbing power, carrying ability, and above all, **guts**. The B-24 can take it and dish it out. The B-24's combat rec-

ord is best told by those who have flown it through flak and swarming fighters, in mission after mission, and know first hand what it can do.

### WHAT COMBAT LEADERS SAY:

"The B-24 has proved itself capable of delivering tremendous blows against the enemy over extremely long ranges, under unfavorable weather conditions and against heavy enemy opposition. If the gunners are properly trained, they can create havoc among enemy fighters. I have seen formations of B-24's penetrate heavily defended battle zones, completely destroy their target, fight off twice their number of enemy fighters and, through their maneuverability and firepower, destroy over 50% of all attacking enemy fighters without loss to themselves."

### There and Back

"In the words of the old-time pilots, 'She'll take you there and bring you back.' I have seen B-24's shot up by 88-mm. anti-aircraft so badly

it seemed impossible that the airplane could stay in the air. One pilot brought his B-24 back to base with half the rudder control completely shot away. We have had airplanes come back under almost unbelievable handicaps: with propellers shot off; with direct hits in gasoline cells by 20, 40 and 88-mm. explosive shells; with the 2 lower engine supports knocked completely off; with both ailerons gone; after complete loss of rudder control; after loss of elevator control. Airplanes have returned with controls so badly damaged they were landed on autopilot."

#### Maneuverability

"A good gunner will conserve his ammunition and make every bullet count. I was caught once, separated from a formation, with no guns working and 500 miles behind enemy front lines, by an enemy plane which had a full load of ammunition. We successfully evaded his attacks and forced him to expend all his ammunition. Maneuverability alone enabled us to return to base. One B-24 was separated from formation over the target and attacked by 15 ME 109's. Through skillful maneuvering and use of firepower this crew shot down 8 of the enemy fighters in a running battle of 100 miles and returned safely to base. In another instance a B-24 with the tail turret out was attacked in a running battle. Enemy fighters knew the vulnerable spot and, as they approached from the rear, the airplane was maneuvered so that the top turret gunner could fire at them. Nine enemy planes were shot down in this manner."

#### Instrument Flying

"The B-24 is a good instrument airplane. About 80% of our flying was instrument or formation or a combination of the two. It is a good indication of your flying ability and of the flight characteristics of the airplane when you can fly formation for 5 or 6 hours and do it well and then go back on instruments and fly a good compass course for 3 or 4 hours. The ability to get your plane back sometimes depends on this. I know that during training in the U. S. it is pretty hard to sit under a hood and fly instruments when you could just be cruising around. It's hard to sit in a Link trainer for hours at a time and work out your procedure. But it pays

off when you get out where you have to be good in formation and instrument flying."

#### Guts

"The housing around the propeller and 3 cylinders of our No. 4 engine were shot out. Two feet of prop on No. 1 engine was smashed, tearing a foot-and-a-half hole in the left aileron. The engine was vibrating like a bucking bronco. And we had a wing cell leak in No. 3. We were both flying that airplane with every ounce of skill we possessed. We put on 10° of flaps to get the best lift without too much drag, and kept our wings straight by using rudder. We muddled through the fighter attack and staggered away from the target on 2½ engines. To gain altitude to cross a mountain range, we threw out everything that was movable, including oxygen bottles, gas masks, ammunition, radio equipment, and everything a screwdriver could get loose. Somehow she brought us back. We had to crash-land the plane but nobody was hurt. The first thing I did after we got away from the plane was to kiss the navigator."

#### Come-Back

"One of the B-24's was hit on the left wing, just outside the outboard engine. I thought the wing would fall off, since the shot went right through the main structure. You could have dropped a barrel through the hole, but the airplane continued to fly formation. A few seconds later a direct hit ripped a big hole in the bomb bay, severed the aileron cable, knocked out the hydraulic and electric systems and the oxygen system. We escorted it 800 miles to the base. It landed without ailerons and without brakes and was back in service in about 3 weeks."

#### Range

A fully loaded Liberator crossed the Atlantic in 6 hours and 12 minutes. The raid on the Rumanian oil refineries was a round trip of 2500 miles. Raids from Midway Island on Jap-held Wake Island involved a round trip of 2400 miles. British Air Chief Marshal Sir Christopher Courtney termed the Liberator the "most successful of all anti-submarine aircraft now used by the United Nations." The combat record of the B-24 speaks for itself.

RESTRICTED



**DUTIES  
AND RESPONSIBILITIES  
of the  
AIRPLANE COMMANDER**

Here's where they separate the men from the boys. You can be one of the best B-24 pilots ever trained and still fail as an airplane commander. In addition to qualifying yourself as a top-flight pilot, you have the job of building a fighting team that you can rely on in any emergency. Failure of any member of the crew to do the right thing at the right time may mean failure of your mission, unnecessary loss of life and possible loss of your airplane.

**You Can't Pass the Buck**

Your authority as airplane commander carries with it responsibility that you can not shirk. Your engineer is a trained specialist, but his training is incomplete. He knows how to transfer fuel, but does he know how to transfer it in the particular airplane you are flying? It isn't enough that he *thinks* so. You must **know** what he knows. It is up to you to perfect the basic training he has been given. An oversight

of this kind cost a B-24 and 2 lives in the Pacific.

You are now flying a 10-man weapon. It is your airplane, and your crew. You are responsible for the safety and efficiency of the crew at all times—not just when you are flying, but for the full 24 hours of every day while you are in command.

Your crew is made up of specialists. Each man—whether he is the navigator, bombardier, engineer, radio operator, or one of the gunners—is an expert in his line. But how well he does his job, and how efficiently he plays his part as a member of your combat team, will depend to a great extent on how well you play your own part as the airplane commander.

#### **Know Your Crew**

Learn all you can about each member of your crew just as soon after he joins your outfit as possible. Where is his home? What is his education? Is he married? What jobs has he had? Where did he get his flight training? How does he like the idea of being assigned to a B-24?

Your job is to learn all you can about each crew member so you can evaluate his qualifications, initiative, proficiency and reliability.

#### **Know His Personal Habits**

It is no business of yours whether a crew member spends his free hours in prayer, gambling, or hunting turtle's eggs unless these habits interfere with the proper performance of his duty. Then his business is your business. You can't afford to see a mission jeopardized because a crew member doesn't get enough sleep, comes to duty with a hangover, starts on a high-altitude mission with gas-producing food in his stomach, or is so distracted by worry that he cannot concentrate on the task at hand.

See that your men are properly quartered, clothed, and fed. There will be many times, when your airplane and crew are away from the home base, when you may even have to carry your interest to the extent of financing them yourself. Remember always that you are the commanding officer of a miniature army—a specialized army; and that morale is one of the biggest problems for the commander of any army, large or small.

RESTRICTED

#### **Crew Discipline**

Your success as the airplane commander will depend in a large measure on the respect, confidence, and trust which the crew feels for you. It will depend also on how well you maintain crew discipline.

Your position commands obedience and respect. This does not mean that you have to be stiff-necked, overbearing, or aloof. Such characteristics certainly will defeat your purpose.

Be friendly, understanding, but firm. Know your job, and, by the way you perform your duties daily, impress upon the crew that you do know your job. Keep close to your men, and let them realize that their interests are uppermost in your mind. Make fair decisions, after due consideration of all the facts involved; but make them in such a way as to impress upon your crew that your decisions are made to stick.

Crew discipline is vitally important, but it need not be as difficult a problem as it sounds. Good discipline in an air crew breeds comradeship and high morale. And the combination is unbeatable.

You can be a good CO and still be a regular guy. You can command respect from your men, and still be one of them.

"To associate discipline with informality, comradeship, a leveling of rank, and at times a shift in actual command away from the leader, may seem paradoxical," says a former combat group commander. "Certainly, it isn't down the military groove. But it is discipline just the same—and the kind of discipline that brings success in the air."

#### **Crew Training**

Train your crew as a team. Keep abreast of their training. It won't be possible for you to follow each man's courses of instruction, but you can keep a close check on his record and progress.

Get to know each man's duties and problems. Know his job, and try to devise ways and means of helping him to perform it more efficiently.

Each crew member naturally feels great pride in the importance of his particular specialty. You can help him to develop this pride

## RESTRICTED

to include the manner in which he performs that duty. To do that you must possess and maintain a very thorough knowledge of each man's job and the problems he has to deal with in the performance of his duties.

### Are You Ready to Fight?

Are your guns working? The only way you can be sure is to know how competent and reliable your gunners are. It is uncomfortable to get caught by a swarm of enemy fighters and find that your guns won't function.

What about your navigator? You can't do his job for him throughout training in the states and expect him to guide you safely over a thousand miles of water to a speck on the map. Remember that there aren't any check points in the ocean and you have to rely on your navigator.

Your bombs miss the target. Long hours of flying wasted . . . why? It may be because the bombsight gyro was not turned on long enough in advance or because the bombsight was not kept warm by means of the heater so that when the bombardier put his warm face to the eyepiece, it fogged up and was unusable. Who is at fault? The bombardier is, of course, primarily to blame, but in the background there is usually lack of leadership, guidance and inspiration. No crew is ever any more on the ball than its airplane commander.

### Practical Questions

1. Are you the airplane commander, qualifying yourself to do justice to your crew?
2. Can all of your crew fly at high altitudes without discomfort or physical handicap?
3. Does anyone in your crew get airsick?
4. Are the turret gunners too big for their turrets?
5. Can the copilot take over in emergency?
6. Does the radio operator understand DF aids?
7. Do the gunners know how to unload and stow their guns?
8. Do the engineer and the copilot (and do you) know how to use the load adjuster and how to load the airplane properly?
9. Do the engineer and copilot (and you) use

the control charts on every flight to check your knowledge of power settings and the efficient performance of your airplane?

10. Does your crew know emergency procedures and signals?

11. Is each member of your crew properly equipped?

12. What can you do to prevent or relieve anoxia, air sickness, fatigue?

13. Who is qualified to render first aid?

14. How's the morale of your outfit? Are they eager or do they sluff off?

15. How will your crew react in emergency?

These are just a few of the practical questions you as airplane commander must be able to answer to your own satisfaction.

---

## RULES TO BE ENFORCED ON EVERY FLIGHT BY THE AIRPLANE COMMANDER

### 1. Smoking

- a. No smoking in airplane at an altitude of less than 1000 feet.
- b. No smoking during fuel transfer.
- c. Never carry lighted cigarette through bomb bays.
- d. Never attempt to throw a lighted cigarette from the airplane. Put it out first.

### 2. Parachutes

- a. All persons aboard will wear parachute harness at all times from takeoff to landing.
- b. Each person aboard will have a parachute on every flight.

### 3. Propellers

- a. No person will walk through propellers at any time whether they are turning or not.
- b. No person will leave the airplane when propellers are turning unless personally ordered to do so by the airplane commander.

### 4. Oxygen Masks

- a. Oxygen masks will be carried on all day flights where altitude may exceed 10,000 feet



and on all night flights, regardless of altitude.

b. Day: All persons will use oxygen starting at 7000 to 10,000 feet on all day flights where altitude at any time will exceed 10,000 feet.

c. Night: All persons will use oxygen from the ground up on all flights during which altitude may exceed 10,000 feet.

#### 5. Training

a. Tell your crew the purpose of each mission and what you expect each to accomplish.

b. Keep the crew busy throughout the flight. Get position reports from the navigator; send them out through the radio operator. Put the engineer to work in the cruise control and maximum range charts. Require the copilot to keep a record of engine performance. Give them a workout. Encourage them to use their skill. Let them sleep in their own bunks—not

in a B-24. A team is an active outfit. Make the most of every practice mission.

c. Practice all emergency procedures at least once a week; bailout, ditching and fire drill.

#### 6. Inspections

a. Check your airplane with reference to the particular mission you are undertaking. **Check everything.**

b. Check your crew for equipment, preparedness and understanding.

#### 7. Interphone

a. Keep the interphone chattering. Ask for immediate reports of aircraft, trains, and ships just as you would expect them in combat—with proper identification.

b. Require interphone reports every 15 minutes from all crew men when on oxygen.

---

## SUGGESTED COMBAT CREW DUTY ASSIGNMENTS

#### PILOT

Principal duty : Airplane Commander  
 Secondary duty: Pilot  
 Added duty : Navigation Specialist

#### COPILOT

Principal duty : Assistant Airplane Commander  
 Secondary duty: Airplane Engineering Officer and Assistant Pilot  
 Added duty : Fire Officer  
 Added duty : Navigational Specialist  
 Added duty : Gunfire Control Officer

#### NAVIGATOR

Principal duty : Navigator  
 Secondary duty: Qualified as Nose Turret Gunner  
 Added duty : Assistant Bombardier  
 Added duty : Oxygen and Equipment Officer  
 Added duty : First Aid Specialist

#### BOMBARDIER

Principal duty : Bombardier  
 Secondary duty: Qualified as Nose Turret Gunner  
 Added duty : Airplane Armament Officer  
 Added duty : Navigation Specialist

## RESTRICTED

### AERIAL ENGINEER

Principal duty : Aerial Engineer  
Secondary duty: Top Turret Gunner  
Added duty : Qualified for Copilot Duties  
Added duty : Parachute Officer  
Added duty : First Aid Specialist  
Added duty : Assistant Radio Operator

### RADIO OPERATOR

Principal duty : Radio Operator  
Secondary duty: Waist Gunner  
Added duty : Assistant Airplane Engineer  
Added duty : First Aid Specialist  
Added duty : Qualified as Top Turret Gunner

### NOSE TURRET GUNNER

Principal duty : /Nose Turret Gunner  
Secondary duty: Turret Specialist  
Added duty : Assistant to Armament Officer

### BELLY TURRET GUNNER

Principal duty : Belly Turret Gunner  
Secondary duty: Turret Specialist

### TAIL TURRET GUNNER

Principal duty : Tail Turret Gunner  
Secondary duty: Turret Specialist  
Added duty : Assistant to Parachute Officer

---

### Purpose of Assigning Added Duties

These assignments are not just so many titles. Each duty represents a specific job to be done. As airplane commander, you are **responsible** for everything but you can't **do** everything. These assignments, properly explained, will arouse the enthusiasm, energy and initiative of your crew. You have the right to demand that each crew member become an expert and maintain expert status in the particular duties assigned to him. There is nothing ironclad about the added duty assignments. These can be shifted around if there is a clear-cut advantage in doing so. For example, the suggested added

duty of the crew oxygen and equipment officer can be shifted from the navigator to the bombardier or to one of the other crew members if he is better qualified or indicates a greater interest in the problem. The main thing is to **spread** the duties, encourage the individual to become an expert and then require him to educate and supervise the rest of the crew regarding his particular specialty. Ask the crew member to read all he can and learn all he can about his specific duties; to be prepared to conduct and aid in inspections and drills, and to give the crew periodic instruction in his

specialty. You, as airplane commander, are the sparkplug of this plan. You will assign duties, call drills, and give your specialists as much opportunity as possible to spread their knowledge. To aid you, here are definitions of some of the less understood added duties.

#### Definitions of Added Duties

**Airplane Engineering Officer**—It is the duty of this officer (almost always the copilot) to know more about the airplane than any member of the crew and to see that all other crew members are instructed in all procedures pertaining to the airplane. The engineering officer should be able, by judicious questioning, to size up a new flight engineer in a few minutes' time. He should be able to perform any of the flight engineer's duties. It is his job to see that all crew members are instructed in the proper methods of transferring fuel. He is charged with the duty of seeing that proper records of engine operations are kept from flight to flight so that faulty operation will be detected before it becomes serious. He should be intimately familiar with the cruise control, climb, and maximum range charts and should educate the engineer in their use.

**Gunfire Control Officer**—It has been found that the copilot is in the best position to serve as gunfire control officer. He has the best view of developing attacks, although he cannot possibly see all enemy fighters. Although he does not attempt to actively direct the fire from all guns, he does supervise the calling of attacks, maintains strict interphone discipline, and sees that the plan and procedure for controlling fire is strictly followed. He is responsible for seeing that the crew is properly indoctrinated in the use of the throat microphone and established practice-mission procedures which will simulate as nearly as possible the interphone conversations that would be necessary in combat. In the heat of battle, crew members tend to talk too fast, speak in too high a tone, or allow the microphone to be improperly placed. The gunfire control officer will develop the interphone proficiency to a point where absolute cooperation between gun stations can be maintained on interphone.

RESTRICTED

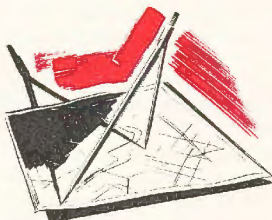

**Navigation Specialist**—Individuals with this assignment should understand all aids to navigation, understand how the navigator's log is kept, and be able in emergency to ascertain the location of the airplane and help to bring it back to base. Obviously, these men cannot be fully qualified navigators, but should know everything possible about navigation procedures that may be of aid in case the navigator is incapacitated.

**Oxygen and Equipment Officer**—This job requires a detailed understanding of the equipment and its operation. This officer confers with the personal equipment officer of the squadron regarding the use of all equipment, precautions to be taken, proper fit and care, and sees that all crew members are properly instructed. He makes periodic inspections of the crew as directed by the pilot to see that oxygen equipment is properly fitted and used. He checks all crew members on the use of walk-around bottles and sees that correct procedures are followed on high-altitude missions.

**First-Aid Specialist**—This assignment should be given, as far as possible, to individuals who already have a good knowledge of first aid. However, there should be one specialist in the nose, one in the rear compartment and one on the flight deck. If individuals in these compartments are not familiar with first aid, pilot should see that they receive adequate instruction. Combat reports reveal that lack of knowledge of first aid has cost lives on combat missions.

**Fire Officer**—This officer, usually the copilot, should know the location of all fire-fighting apparatus and know specifically when and how to use it. He should instruct the entire crew on their exact duties in case of fires. He will

## RESTRICTED

arrange a program of fire drill with the pilot, aid in conducting the drill, and point out all mistakes. He will conduct a periodic inspection of the ship for fire hazards, see that the fire prevention rules are obeyed and be responsible to the pilot for proper precautions against fire.

**Qualified as Turret Gunner**—Crew members whose stations are adjacent to turrets should be able to take over the turret and operate it if emergency requires. Turret specialists instruct such crew members in the operation of the turret and use spare time in flight and on the ground to qualify such crew members as emergency turret gunners. Then they can give assistance in case of trouble with the turret or if the turret specialist is incapacitated.

**Airplane Armament Officer**—The armament officer must be familiar with all armament the airplane carries, the protection it provides and how it can best be used. In addition to his duties in connection with the loading, arming and dropping of bombs, he aids the pilot in enforcing the safety regulations regarding practice bombing, practice gunnery, and proper loading, unloading, and stowing of guns. In case of accidental discharge of a gun, he, with the gunner and pilot, will usually be considered at fault, on the ground that he has insufficiently instructed the gunner in procedures and precautions.

**Parachute Officer**—This officer will see that each crew member has his own properly fitted parachute, that he knows how to use it, that he knows how and where to leave the plane and how to open the chute and descend. (See PIF.) He will plan a drill schedule with the pilot and aid in parachute drill. Through the pilot he will see that rules regarding the care, inspection, fitting and wearing of parachutes

are observed in accordance with AAF regulations and requirements.

**Turret Specialist**—The turret specialist must know not only how to operate his turret but how to repair it and put it back in operation if necessary. He will give instruction at every opportunity to crew members near his station to qualify them as assistant turret gunners.

**Assistant Assignments**—An assistant is one who can take over a job and do it as well as the regularly assigned individual if necessary. The assistant radio operator, for example, should be able to take over and operate the radio as well (or almost as well) as the regular radio operator, etc. The most valuable man on a team is the one who can take over other jobs than his own if and when required to do so.

The above is by no means a complete statement of this problem but it should give the airplane commander the idea of what it means to "train your crew," for every man to "know every other man's job," and what is meant by teamwork. These are not empty phrases. Every 15 minutes wasted on a mission means your crew is 15 minutes less well prepared for combat. There is no reason for your radio equipment to be idle. Your engineer has no time to sleep or sit and vegetate if he is carrying out his job of teaching all crew members to transfer fuel, working the cruise control charts, really keeping on the ball. You have to fly a practice mission . . . so why not run it so that your crew will get all they can out of it? It is real pleasure to develop topnotch proficiency and teamwork, and your crew will actually enjoy missions more if they feel that their skills are being utilized to the fullest extent, if only in practice.

It is worth while to discuss here also the principal duties of each of the crew members to aid the commander in judging their ability.



### COPILOT

The copilot is the executive officer: your chief assistant, understudy, and strong right arm. He must be familiar enough with every one of your duties—both as pilot and airplane commander—and be able to take over and act in your place at any time.

He must be able to fly the airplane under all conditions as well as you would fly it yourself.

He must be extremely proficient in engine operation, and know instinctively what to do to keep the airplane flying smoothly even though he is not handling the controls.

He must have a thorough knowledge of cruising control data, and know how to apply it at the proper time.

He is also the engineering officer aboard the airplane, and maintains a complete log of performance data.

He must be a qualified instrument pilot.

He must be qualified to navigate during day or night by pilotage, dead reckoning, and by use of radio aids.

He must be proficient in the operation of all radio equipment located in the pilot's compartment.

In formation flying, he must be able to make engine adjustments almost automatically.

He must be prepared to take over on instruments when the formation is climbing through an overcast, thus enabling you to watch the rest of the formation.

Always remember that the copilot is a fully trained, rated pilot just like yourself. He is subordinate to you only by virtue of your position as the airplane commander. But the B-24 is a lot of airplane; more airplane than any one pilot can handle alone over a long period of time. Therefore, you have been provided with

a second pilot who will share the duties of flight operation.

Treat your copilot as a brother pilot. Remember that the more proficient he is as a pilot, the more efficiently he will be able to perform the duties of the vital post he holds as your second in command.

Be sure that he is always allowed to do his share of the flying, in the copilot's seat, on take-offs, landings, and on instruments.

The importance of the copilot is eloquently testified by airplane commanders overseas. There have been numerous cases in which the pilot has been disabled or killed in flight and the copilot has taken full command of both airplane and crew, completed the mission, and returned safely to the home base. Usually, the copilots who have distinguished themselves under such conditions have been copilots who have been respected and trained by the airplane commander as pilots.

Bear in mind that the pilot in the right-hand seat of your airplane is preparing himself for an airplane commander's post too. Allow him every chance to develop his ability and to profit by your experience.



### NAVIGATOR

The navigator's job is to direct your flight from departure to destination and return. He must know the exact position of the airplane at all times. In order for you to understand fully how best to get most reliable service from your navigator, you must know as much about his job as possible.

Navigation is the art of determining geographic positions by means of (a) pilotage, (b) dead reckoning, (c) radio, or (d) celestial navigation, or any combination of these 4 methods. By any one or combination of methods the navigator determines the position of the airplane in relation to the earth.

## RESTRICTED

### Pilotage

Pilotage is the method of determining the airplane's position by visual reference to the ground. The importance of accurate pilotage cannot be overstressed. In combat navigation, all bombing targets are approached by pilotage, and in many theaters the route is maintained by pilotage. This requires not merely the vicinity type, but **pin-point pilotage**. The exact position of the airplane must be known not within 5 miles, but within  $\frac{1}{4}$  of a mile.

The navigator does this by constant reference to groundspeeds, the ground, and to his maps and charts. ETA's are established for points ahead. During the mission, as long as he can maintain visual contact with the ground, the navigator can establish these pin-point positions so that the exact track of the airplane will be known when the mission is completed.

### Dead Reckoning

Dead reckoning is the basis of all other types of navigation. For instance, if the navigator is doing pilotage, and computes ETA's for points ahead, he is using dead reckoning.

Dead reckoning determines the position of the airplane at any given time by keeping an account of the track and distance flown over the earth's surface from the point of departure or the last known position.

Dead reckoning can be subdivided into two classes:

1. **Dead reckoning based on a series of known positions.** For example, you, as pilot, start on a mission at 25,000 feet. For the first hour your navigator keeps track by pilotage, at the same time recording the heading and airspeed which you are holding. According to plan at the end of the first hour the airplane goes above the clouds, thus losing contact with the ground. By means of dead reckoning from his last pilotage point, the navigator is able to tell the position of the aircraft at any time. The first hour's travel has given him the wind prevalent at the altitude, and the track and groundspeed being made. By computing track and distance from the last pilotage point, he can always tell the position of the airplane. When your airplane

comes out of the clouds near the target, the navigator will have a very close approximation of his exact position, and will be able to pick up pilotage points very quickly.

2. **Dead reckoning as a result of visual references other than pilotage.** When flying over water, desert, or barren land, where no reliable pilotage points are available, very accurate DR navigation still can be performed. By means of the drift meter the navigator is able to determine drift, the angle between the heading of the aircraft and the track of the aircraft over the ground. The true heading of the aircraft is obtained by application of compass error to the compass reading. The true heading plus or minus the drift (as read on the drift meter) gives the track of the airplane. At a constant airspeed, drift on 2 or more headings will give the navigator information necessary to obtain the wind by use of his computer. Groundspeed is computed easily once the wind, heading, and airspeed are known. So by constant recording of true heading, true airspeed, drift, and groundspeed, the navigator is able to determine accurately the position of the aircraft at any given time. For greatest accuracy, constant courses and airspeeds must be maintained by the pilot. If course or airspeed is changed, notify the navigator so he can record these changes.

### Radio

Radio navigation makes use of various radio aids to determine position. The development of many new radio devices has increased the use of radio in combat zones. However, the ease with which radio aids can be jammed, or bent, limits the use of radio to that of a check on DR and pilotage. The navigator, in conjunction with the radioman, is responsible for all radio procedures, approaches, etc., that are in effect in the theater.

### Celestial

Celestial navigation is the science of determining position by reference to 2 or more celestial bodies. The navigator uses a sextant accurate time and numerous tables to obtain what

he calls a line of position. Actually this line is part of a circle on which the altitude of the particular body is constant for that instant of time. An intersection of 2 or more of these lines gives the navigator a fix. These fixes can be relied on as being accurate within approximately 10 miles. The reason for inaccuracy is the instability of the airplane as it moves through space, causing acceleration of the sextant bubble (a level denoting the horizontal). Because of this acceleration, the navigator takes observations over a period of time so that the acceleration error will cancel out to some extent. If the navigator tells the pilot when he wishes to take an observation, extremely careful flying on the part of the pilot during the few minutes it takes to make the observations will result in much greater accuracy. Generally speaking, the only celestial navigation used by a combat crew is during the delivering flight to the theater. But in all cases celestial navigation is used as a check on dead reckoning and pilotage except where celestial is the only method available, such as on long over-water flights, etc.

#### Instrument Calibration

Instrument calibration is an important duty of the navigator. All navigation depends directly on the accuracy of his instruments. Correct calibration requires close cooperation and extremely careful flying by the pilot. Instruments to be calibrated include the altimeter, all compasses, airspeed indicators, alignment of the astrocompass, astrograph, and drift meter, and checks on the navigator's sextant and watch.

#### Pilot-Navigator Preflight Planning

1. Pilot and navigator must study flight plan of the route to be flown, and select alternate airports.
2. Study the weather with the navigator. Know what weather you are likely to encounter. Decide what action is to be taken. Know the weather conditions at the alternate airports.
3. Inform your navigator of what airspeed and altitude you wish to fly so that he can prepare his flight plan.
4. Learn what type of navigation the navigator intends to use: pilotage, dead reckoning,

radio, celestial, or a combination of all methods.

5. Determine check points; plan to make radio fixes.
6. Work out an effective communication method with your navigator to be used in flight.
7. Synchronize your watch with your navigator's.

#### Pilot-Navigator in Flight

1. **Constant course**—For accurate navigation you, the pilot, must fly a constant course. The navigator has many computations and notations to make in his log. Constantly changing course makes his job more difficult. A good navigator is supposed to be able to follow the pilot, but he cannot be taking compass readings all the time.

2. **Constant airspeed** must be held as nearly as possible. This is as important to the navigator as is a constant course in determining position.

3. **Precision flying** by the pilot greatly affects the accuracy of the navigator's instrument readings, particularly celestial readings. A slight error in celestial reading can cause considerable error in determining positions. You can help the navigator by providing as steady a platform as possible from which he can take readings. The navigator should notify you when he intends to take readings so that the airplane can be leveled off and flown as smoothly as possible preferably by using the automatic pilot. Do not allow your navigator to be disturbed while he is taking celestial readings.

4. **Notify the navigator in advance of any change in flight** such as change in altitude, course, or airspeed. If change in flight plan is to be made, consult the navigator. Talk over the proposed change so that he can plan the flight and advise you concerning it.

5. In the event there is doubt as to the position of the airplane, pilot and navigator should work together, refer to the navigator's flight log, talk the problem over and decide together the best course of action to take.

6. Check your compasses at intervals with those of the navigator, noting any deviation.

7. Require your navigator to give position reports at regular intervals.

## RESTRICTED

8. You are ultimately responsible for getting the airplane to its destination. Therefore, it is your duty to know your position at all times.

9. Encourage your navigator to use as many of the methods of navigation as possible as a means of double-checking and for practice.

### Post-flight Critique

After every flight get together with the navigator and discuss the flight and compare notes. Go over the navigator's log. If there have been serious navigational errors, discuss them with the navigator and determine their cause. If the navigator has been at fault, caution him that it is his job to see that the same mistake does not occur again. If the error has been caused by faulty instruments, see that they are corrected before another navigation mission is attempted. If your flying has contributed to the inaccuracy of the navigation, try to fly a better course the next mission.

### Miscellaneous Duties

The navigator's primary duty is navigating your airplane with a high degree of accuracy. But as a member of the team, he must also have a general knowledge of the entire operation of the airplane.

He has a .50-cal. machine gun at his station, and he must be able to use it skillfully and to service it in emergencies.

He must be familiar with the oxygen system, know how to operate the turrets, radio equipment, and fuel transfer system.

He must know the location of all fuses and spare fuses, lights and spare lights, affecting navigation.

He must be familiar with emergency procedures, such as the manual operation of landing gear, bomb bay doors, and flaps, and the proper procedures for crash landings, ditching, bailout, etc.

## THE BOMBARDIER

Accurate and effective bombing is the ultimate purpose of your entire airplane and crew. Every other function is preparatory to hitting and destroying the target.

That's your bombardier's job. The success or failure of the mission depends upon what



he accomplishes in the short interval of the bombing run.

When the bombardier takes over the airplane for the run on the target, he is in command. He will tell you what he wants done, and until he gives you the word "Bombs away," his word is virtually law.

A great deal, therefore depends on the understanding between bombardier and pilot. You expect your bombardier to know his job when he takes over. He expects you to understand the problems involved in his job, and to give him full cooperation. Teamwork between pilot and bombardier is essential.

Under any given set of conditions, ground speed, altitude, direction, etc., there is only one point in space where a bomb may be released from the airplane to hit a predetermined object on the ground.

There are many things with which a bombardier must be thoroughly familiar in order to release his bombs at the right point to hit this predetermined target.

He must know and understand his bomb-sight, what it does, and how it does it.

He must thoroughly understand the operation and upkeep of his bombing instruments and equipment.

He must know that his racks, switches, controls, releases, doors, linkage, etc., are in first-class operating condition.

He must understand the automatic pilot as it pertains to bombing.

He must know how to set it up, make air adjustments and minor repairs while in flight.

He must know how to operate all gun positions in the airplane.

He must know how to load and how to clear simple stoppages and jams of guns in flight.

He must be able to load and fuse his own bombs.



He must understand the destruction power of bombs and must know the vulnerable spots on various types of targets.

He must understand the bombing problem, bombing probabilities, bombing errors, etc.

He must be thoroughly versed in target identification and in aircraft identification.

The bombardier should be familiar with the duties of all members of the crew and should be able to assist the navigator in case the navigator becomes incapacitated.

For the bombardier to be able to do his job, the pilot of the aircraft must place the aircraft in the proper position to arrive at a point on a circle about the target from which the bombs can be released to hit the target.

Unless the pilot performs his part of the bombing run correctly, even the best bombardier in the world will be unable to bomb accurately. The pilot's failure to hold airspeed and altitude will cause the following bombing errors:

1. Flying too high: bomb will hit over.
2. Flying too low: bomb will fall short.
3. Flying too fast: bomb will fall short.
4. Flying too slow: bomb will hit over.



### THE RADIO OPERATOR

There is a lot of radio equipment in today's B-24's. There is one special man who is supposed to know all there is to know about this equipment. Sometimes he does but often he doesn't. His deficiencies often do not become apparent until the crew is in the combat zone, when it is too late. Too often the lives of pilots and crew are lost because the radio operator has accepted his responsibility indifferently.

Radio is a subject that cannot be learned in a day. It cannot be mastered in 6 weeks, but sufficient knowledge can be imparted to the radio man during his period of training in the United States providing he is willing to study.

RESTRICTED

It is imperative that you check your radio operator's ability to handle his job before taking him overseas as part of your crew. To do this you may have to check the various instructor-departments to find out any weakness in the radio operator's training and proficiency and to aid the instructors in overcoming such weaknesses.

Training in the various phases of the heavy bomber program is designed to fit each member of the crew for the handling of his jobs. The radio operator will be required to:

1. Render position reports every 30 minutes.
2. Assist the navigator in taking fixes.
3. Keep the liaison and command sets properly tuned and in good operating order.
4. Understand from an operational point of view:

- (a) Instrument landing
- (b) IFF
- (c) VHF

and other navigational aids equipment in your airplane.

5. Maintain a log.

In addition to being radio operator, the radio man is also a gunner. During periods of combat he will be required to leave his watch at the radio and take up his guns. He is often required to learn photography. Some of the best pictures taken in the Southwest Pacific were taken by radio operators. The radio operator who cannot perform his job properly may be the weakest member of your crew. And the crew is no stronger than its weakest member.



### THE ENGINEER

Size up the man who is to be your engineer. This man is supposed to know more about the mechanical features of the airplane you are to fly than any other member of the crew.

## RESTRICTED

He has been trained in the Air Forces' highly specialized technical schools. Probably he has served some time as a crew chief. Nevertheless there may be some blank spots in his training which you, as a pilot and airplane commander, must fill in.

Think back on your own training. In many courses of instruction, you had a lot of things thrown at you from right and left. You had to concentrate on how to fly; and where your equipment was concerned you learned to rely more and more on the enlisted personnel, particularly the crew chief and the engineer, to advise you about things that were not taught to you because of lack of time and the arrangement of the training program.

Both pilot and engineer have a responsibility to work closely together to supplement and fill in the blank spots in each other's education.

To be a qualified combat engineer a man must know his airplane, his engines, and his armament equipment thoroughly and know how to strip, clean and re-assemble the guns. This is a big responsibility: the lives of the entire crew, the safety of the equipment, the success of the mission depend squarely upon it.

He must work closely with the copilot, checking engine operation, fuel consumption, and the operation of all equipment.

He must be able to work with the bombardier, and know how to cock, lock, and load the bomb racks.

It is up to you, the airplane commander, to see that he is familiar with these duties, and, if he is hazy concerning them, to have the bombardier give him special help and instruction.

He should have a general knowledge of radio equipment and be able to assist in tuning transmitters and receivers.

Your engineer should be your chief source of information concerning the airplane. He should know more about the equipment than anyone, yourself included.

You, in turn, are his source of information concerning flying. Bear this in mind in all your discussions with the engineer. The more complete you can make his knowledge of the reasons behind every function of the equipment,

the more valuable he will be as a member of the crew. Who knows? Some day that little bit of extra knowledge in the engineer's mind may save the day in an emergency.

Generally, in emergencies, the engineer will be the man to whom you turn first. Build up his pride, his confidence, his knowledge. Know him personally; check on the extent of his knowledge. Make him a man upon whom you can rely.



## THE GUNNERS

The B-24 is a most effective gun platform, but its effectiveness can be either amplified or defeated by the way the gunners in your crew perform their duties in action.

Your gunners belong to one of two distinct categories: turret gunners and flexible gunners.

The power turret gunners require many mental and physical qualities similar to what we know as inherent flying ability, since the operation of the power turret and gunsight are much like airplane operation.

While the flexible gunner does not require the same delicate touch as the turret gunner, he must have a fine sense of timing and be familiar with the rudiments of exterior ballistics.

All gunners should be familiar with the coverage area of all gun positions, and be prepared to bring the proper gun to bear as the condition may warrant.

They should be experts in aircraft identification.

Where the Sperry turret is used, failure to set the target dimension dial properly on the K-type sight will result in miscalculation of range.

They must be familiar thoroughly with the Browning aircraft machine gun. They should know how to maintain the guns, how to clear

jams and stoppages, and how to harmonize the sights with the guns.

While participating in training flights, the gunners should be operating their turrets constantly, tracking with the flexible guns even when actual firing is not practical. Other airplanes flying in the vicinity offer excellent tracking targets. Automobiles, houses, and other ground objects afford excellent tracking targets during low-altitude flights.

The importance of teamwork cannot be over-

emphasized. One poorly trained gunner, or one man not on the alert, can be the weak link that destroys the entire crew.

Keep the interest of your gunners alive at all times. Any form of competition among the gunners themselves will stimulate interest to a high degree.

Finally, each gunner should fire the guns at each station to familiarize himself with the other man's position and to insure knowledge of operation in the event of an emergency.

# GENERAL SPECIFICATIONS

## DIMENSIONS

### A. AIRPLANE—GENERAL

Fuselage Height	10' 5"
Over-all Span	110' 0"
Over-all Length	67' 2"
Over-all Height	17' 11"
Clearance, Inboard Propeller Tip to Ground	2' 10 <sup>1</sup> / <sub>2</sub> "
Clearance, Outboard Propeller Tip to Ground	3' 3 <sup>1</sup> / <sub>2</sub> "
Clearance, Propeller Tip to Fuselage	1' 9"
Clearance, Inboard to Outboard Propeller Tips	2' 6"
Clearance, Propeller to Wing Leading Edge	6' 2 1/16"
Clearance, Bottom of Fuselage to Ground	1' 8"

### B. WINGS

Root Chord	14' 0"
Dihedral	3° 26'
Incidence	3° 0'
Sweep—Leading Edge	3° 30'
Total Wing Area (Including Ailerons)	1048 sq. ft.

### C. FLAPS

Area (Total)	144.1 sq. ft.
Chord (Maximum)	2' 7 7/16"
Movement of Flaps (Maximum Down)	40°

### D.AILERONS

Total Area (each)	41.55 sq. ft.
Movement of Aileron, Up	20°
Down	20°
Area of Aileron Tab (Right Aileron)	2.52 sq. ft.
Movement of Tab, Up	10°
Down	10°

### E. TAIL GROUP

(1) Horizontal Stabilizer	
Over-all Span	26' 0"
Total Area	140.54 sq. ft.
(2) Elevators	
Total Area	60.06 sq. ft.
Movement of Elevator, Up	30°
Down	20°
Area of Elevator Tab (Both)	2.40 sq. ft.
Movement of Tab, Up	10°
Down	10°
(3) Vertical Fins	
Area (Both)	139.0 sq. ft.
(4) Rudders	
Total Area (Both)	65.0 sq. ft.
Movement (To Each Side)	20°
Area of Rudder Tabs (Both)	1.92 sq. ft.
Movement of Tab (Each Side)	10°

### F. LANDING GEAR

Tread	25' 7 <sup>1</sup> / <sub>2</sub> "
Wheel Base (Fore and Aft)	16' 0"

### NOTE:

It is impractical to include in a manual of this kind all data for all series. The object is to give the pilot a general picture of the B-24 airplane. It is your obligation to note and investigate the

individual differences in the particular airplane you are flying. Refer to the technical orders available in the airplane and at your base. Remember that you can never know too much about your airplane.

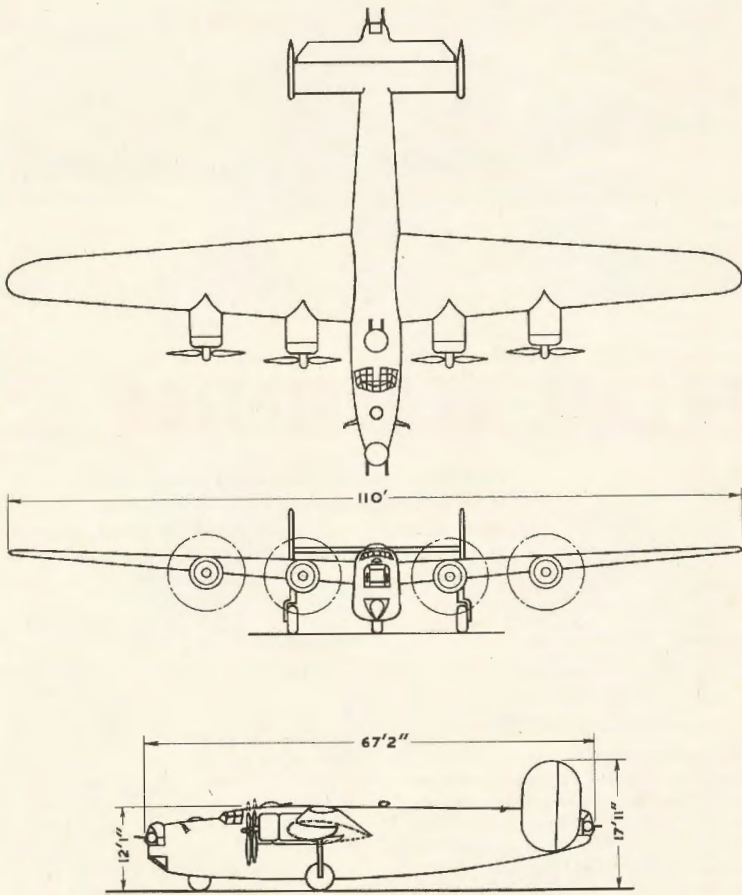



## GENERAL DESCRIPTION

The B-24 is a midwing, land, heavy bombardment airplane of the following approximate over-all dimensions: length 67 feet, 2 inches; height 17 feet, 11 inches; span 110 feet. Weight varies from a basic weight of approximately 38,000 lb. to combat loads of over 60,000 lb.

### Compartments

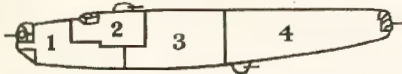

1. Bombardier-navigator's compartment, in the nose of the airplane, contains navigational equipment, bombsight, bomb controls, and nose guns, or in the case of later models, nose turret.

2. Flight deck includes pilots' compartment, radio operator's station and top gun turret.

3. Two bomb bays are in the center of the fuselage under the center wing section. Half deck is located above the rear bomb bay.

4. Rear fuselage compartment contains lower gun turret, waist guns, bottom camera hatch, and photographic equipment. Tail gun turret is in the extreme rear of the fuselage.

### Landing Gear

The tricycle gear consists of 2 main wheels and a nosewheel, mounted on air-oil shock struts. The nosewheel is free to swivel 45° each way but should never be turned more than 30°; it is damped against shimmying.

All 3 units are normally extended and retracted hydraulically by a lever on the pilot's control pedestal which also operates the landing gear locking mechanism.

The retractable shock-mounted tail bumper (or tailskid) is operated simultaneously with the landing gear (B-24 C's and early B-24 D's have non-retractable tail bumpers).

The inherent directional stability of the tricycle gear is an important aid to the pilot during taxiing, takeoff, landing operation in crosswinds, and with blown tires.

### Equipment and Systems

The various types of equipment and systems such as the fuel, oil, hydraulic, and other systems are described in detail in separate sections of this manual. Specific and complete practical understanding of these systems is imperative for the pilot because of the emergencies which arise in combat operations.

### Armament

Protective armor plate and guns are provided at crew stations as shown in the accompanying illustrations.

### Davis Wing

The B-24 wing is an internally braced, skin-stressed type, tapered, with a high aspect ratio. It is considered one of the most efficient airfoils ever developed and was a radical departure from airfoils in use when the Liberator was designed. Its unusual efficiency accounts

for the combination of high speed, long range and great load-carrying qualities of the airplane. Flaps greatly vary the lift-drag characteristics of the wing, as is evidenced by the fact that normal takeoffs are made with 20° of flaps, that maximum lift and stability at slow cruising speeds can be obtained with 5° to 9° of flaps, and that 10°, 20°, and 40° of flaps effect successively larger reductions in stalling speeds.

### Propellers

The 3-bladed propellers are Hamilton-Standard, hydromatic, full-feathering, controllable pitch, constant-speed. Toggle switches on the pilot's pedestal electrically control the governors which maintain the constant-speed feature. To operate the B-24 safely it is imperative that pilots fully understand the principle of the constant-speed propeller, its relationship to engine pressures (manifold pressure and brake mean effective pressure) and know when and when not to use the feathering feature.

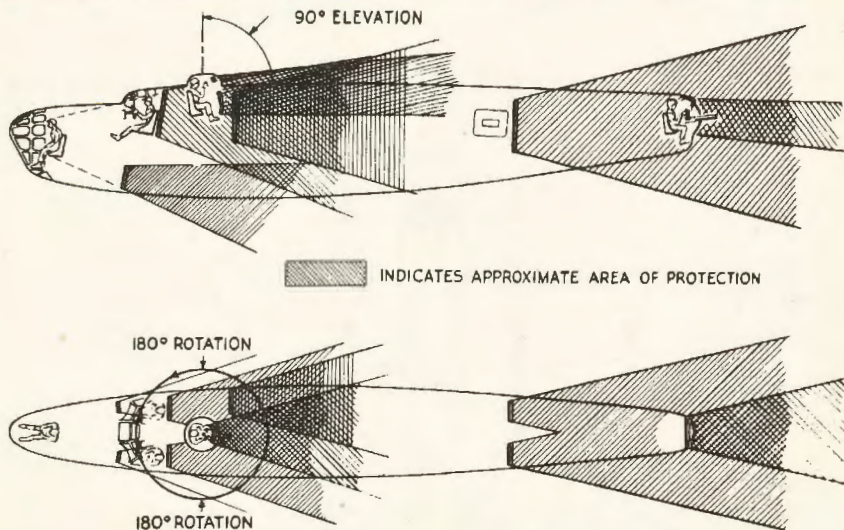

Armament and Angles of Armor Protection Diagram B-24D

## RESTRICTED

### Ignition

Engine ignition is provided by 2 American Bosch magnetos, mounted on the rear section of each engine. Separate switches permit either one or both magnetos to be operated on the engine. Battery switches are on the copilot's auxiliary switch panel. A master switch bar located just above the magneto switches is available for simultaneously shorting the primaries of all magnetos and for opening the battery circuit of the main electrical system.

### Cowl Flaps

Engine cooling is regulated by means of adjustable cowl flaps which are controlled electrically from the pilot's pedestal. The range of cowl flap control is from closed to  $12\frac{1}{4}^{\circ}$  to  $30^{\circ}$  open, depending on the model airplane.

### Carburetors

On No. 42-41115 and subsequent aircraft the Bendix Stromberg carburetor is replaced by the Chandler Evans Co. (Ceco) carburetor.

### Engines

The B-24 is equipped with 4 Pratt & Whitney 14-cylinder, twin-row radial, air-cooled engines with internal single-stage, single-speed, engine-driven integral superchargers. Engines are rated to produce up to a total of 4800 horsepower using Grade 100 fuel and takeoff power settings.

Each of the 4 engines is equipped with a turbo-supercharger to furnish compressed air to the fuel induction system at sea-level pressure.

### Control Surfaces

Rudders, elevators and ailerons are equipped with trim tabs (except left aileron) and are fabric covered; all other surfaces are metal covered.

### Wing Flaps

The all-metal, Fowler-type wing flaps retract into the wing center section trailing edge wells. Maximum down travel is  $40^{\circ}$ .

## THE ENGINES HAVE THE FOLLOWING ACCESSORIES

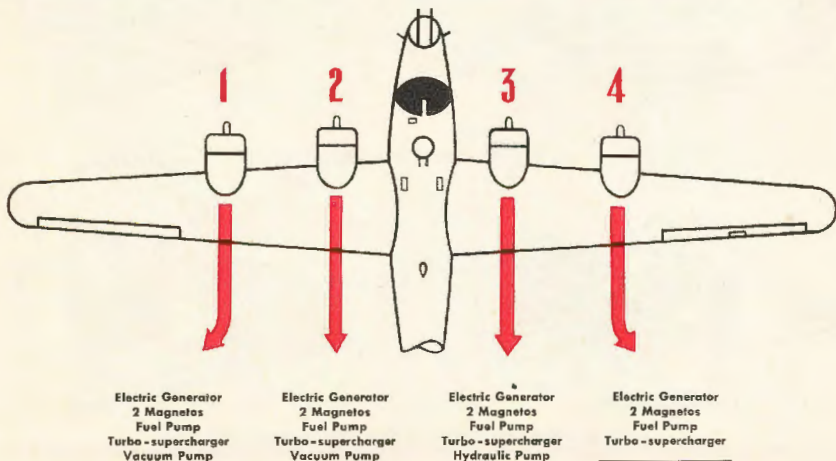



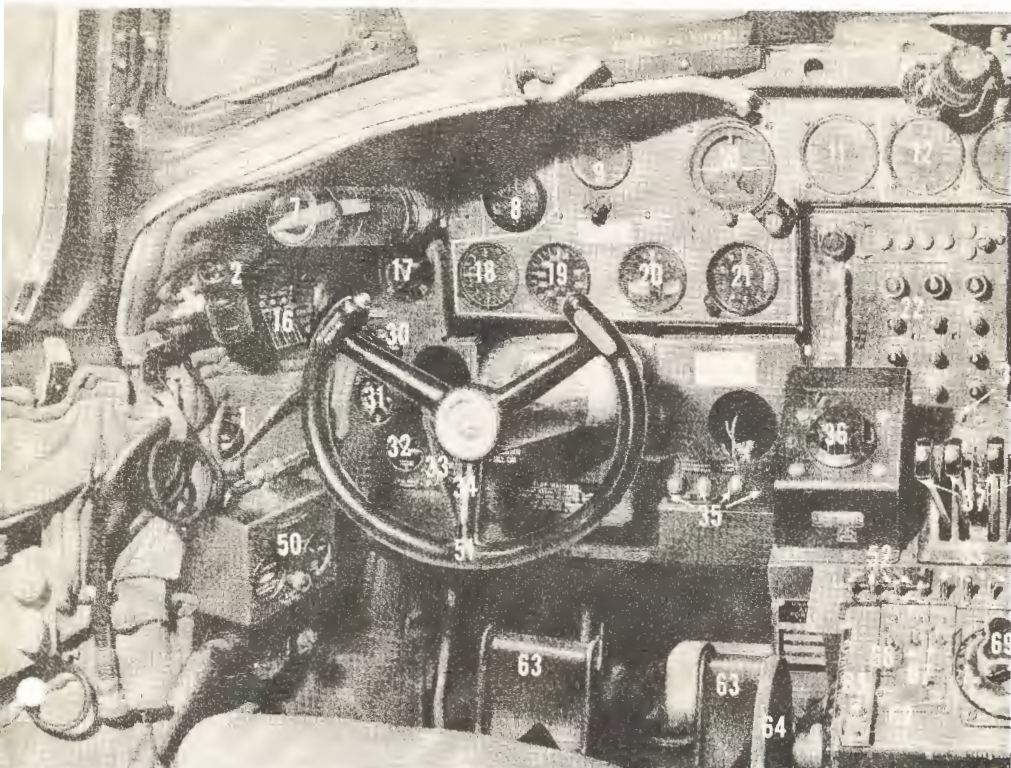

## *Cockpit of the Liberator...* B-24 PI

- |                                    |  |
|------------------------------------|--|
| 1. Fluorescent Light Switches      | 19. Airspeed Indicator                 |
| 2. 24 Volt DC Fluorescent Light    | 20. Turn and Bank Indicator            |
| 3. Magnetic Compass Light Rheostat | 21. Altimeter                          |
| 4. IFF Radio Destroyer Switch      | 22. C-1 Automatic Pilot                |
| 5. Bomb Doors Indicator            | 23. Marker Beacon Indicator            |
| 6. Bomb Release Indicator          | 24. Landing Gear Indicator Test Button |
| 7. Defroster Ducts                 | 25. Flap Position Indicator            |
| 8. Pilot Director Indicator        | 26. Landing Gear Indicator             |
| 9. Directional Gyro                | 27. Free Air Temperature Gage          |
| 10. Gyro Horizon                   | 28. Oil Pressure Gages                 |
| 11. Radio Compass Indicator        | 29. Oil Temperature Gages              |
| 12. Manifold Pressure Gages        | 30. Hydraulic Pressure Gages           |
| 13. Tachometers                    | 31. Suction Gage                       |
| 14. Fuel Pressure Gages            | 32. Inboard Brake Pressure Gage        |
| 15. Cylinder Temperature Gages     | 33. Outboard Brake Pressure Gage       |
| 16. Chemical Release Switches      | 34. Defroster Controls                 |
| 17. Ventilators                    | 35. Propeller Governor Limit Lights    |
| 18. Rate-of-climb Indicator        | 36. Turbo Boost Selector               |

RESTRICTED

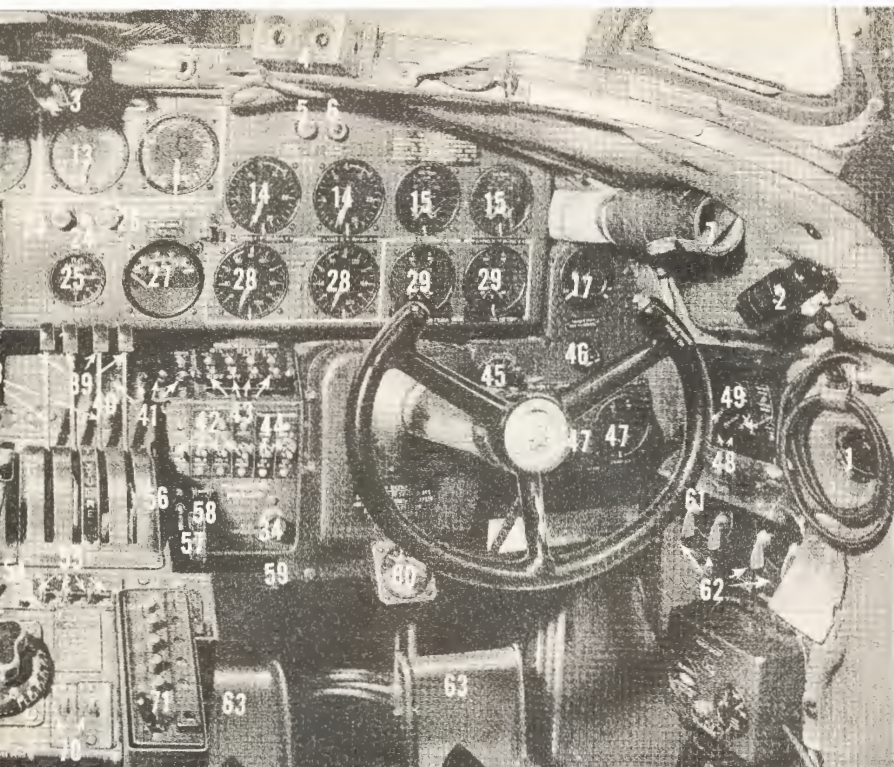

## OT'S INSTRUMENTS AND CONTROLS

- |   |                                   |
|---|-----------------------------------|
| 37. Throttles                             | 55. Cowl Flap Switches            |
| 38. Propeller Feathering Circuit Breakers | 56. SCR 535 Power Switch          |
| 39. Mixture Controls                      | 57. Throttle Friction Lock        |
| 40. Bomb Bay Fuel Transfer Switch         | 58. SCR 535 Emergency Switch      |
| 41. Booster Pump Switches                 | 59. De-icer Control               |
| 42. Engine Starter Switches               | 60. De-icer Pressure Gage         |
| 43. Oil Dilution Switches                 | 61. Emergency Ignition Switch Bar |
| 44. Primer Switches                       | 62. Ignition Switches             |
| 45. Anti-icer Control                     | 63. Brake Pedals                  |
| 46. Formation Lights Rheostat             | 64. Elevator Tab Control Wheel    |
| 47. Carburetor Air Temperature Gages      | 65. Alarm Button                  |
| 48. Main Storage Battery Switches         | 66. Passing Light Switch          |
| 49. Heater and Defroster Switches         | 67. Navigation Light Switches     |
| 50. Oxygen Panels                         | 68. A C Inverter Switch           |
| 51. Pilot's Wheel                         | 69. Rudder Tab Control Knob       |
| 52. Propeller Switches                    | 70. Landing Light Switches        |
| 53. Intercooler Shutter Switches          | 71. SCR 522 Control Box           |
| 54. Pitot Heater Switch                   |                                   |

RESTRICTED

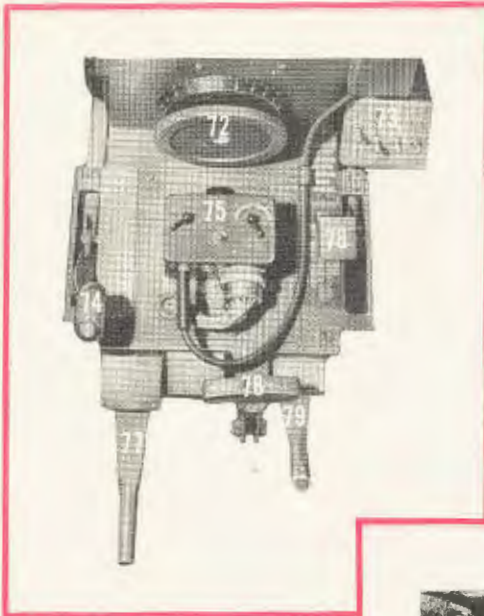

- 72. Aileron Tab Control Wheel
- 73. Recognition Light Switches
- 74. Landing Gear Control Lever
- 75. Command Radio Transmitter Control Box
- 76. Wing Flap Control Lever
- 77. Parking Brake Handle
- 78. Emergency Bomb Release Handle
- 79. Controls Lock Handle

**BASE OF  
CONTROL PEDESTAL**

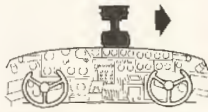
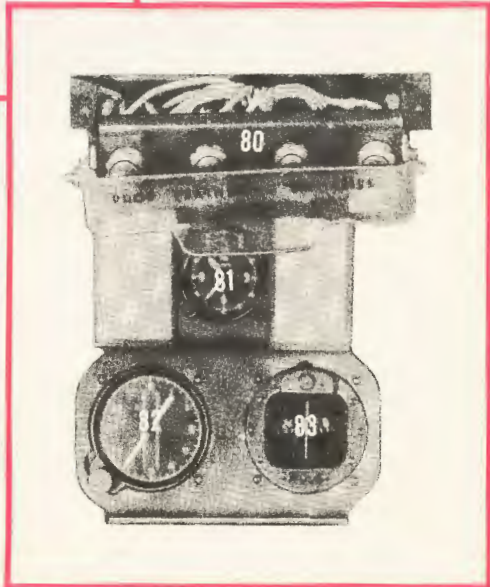
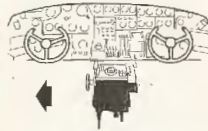

**ABOVE INSTRUMENT  
PANEL**

- 80. Propeller Feathering Switches
- 81. Clock
- 82. Remote Indicating Compass
- 83. Magnetic Compass

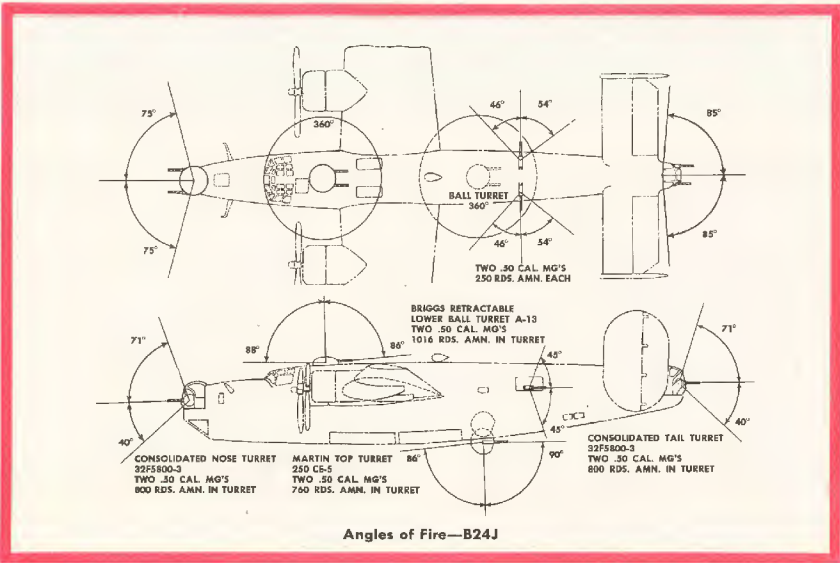
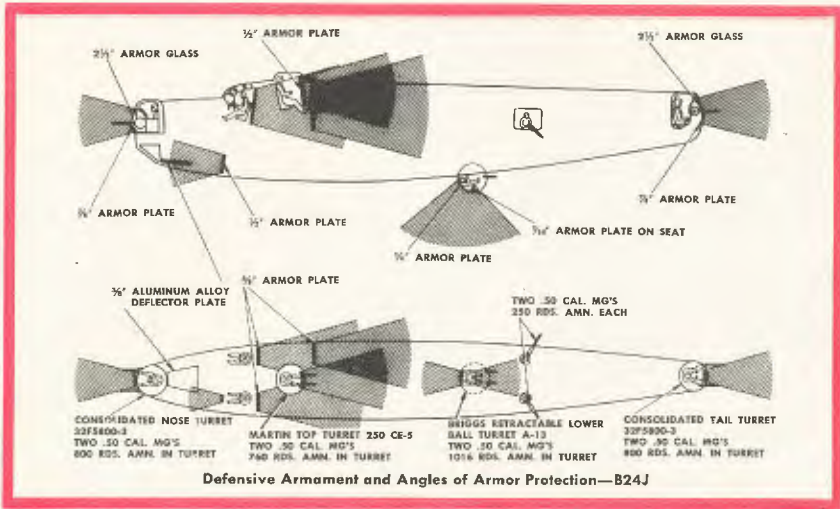

RESTRICTED



## PRESENTING THE B-24N

The new B-24N will soon be in operation in many bases in the continental United States. It incorporates a number of changes and new features developed as a result of the airplane's extensive combat experience.

The major difference in the exterior appearance of the B-24N is the single vertical stabilizer. Also, the new nose turret installation is ball type. This change has cleaned up the nose and greatly increased the pilot's forward visibility.

The most important change in the inside, as far as the pilot is concerned, is the relocation of many of the switches. Also, some of the instruments and other equipment have been moved.

The general flight characteristics of the B-24N are basically the same as those of other series, and stalling speeds are the same. The principal difference is that in earlier B-24 airplanes the rudder does not give enough directional control at low airspeeds (around 130 mph) with an outboard engine not working. In the B-24N, however, rudder control is good enough to maintain straight flight with

no yaw under these conditions. You can cruise with two engines out on one side at airspeeds of 150 to 155 mph and trim the airplane to fly "hands off." This condition has been tested, with No. 1 and No. 2 feathered and No. 3 and No. 4 pulling nearly rated power.

The control pressures have been improved making it much easier to hold the airplane under unbalanced power conditions. The rudder pressures are now considerably lighter, and aileron and elevator pressures have been lightened to a point where they are very satisfactory.

The B-24N is powered with four Pratt-Whitney, Model R-1830-75 engines, which allow more horsepower for takeoff.

The takeoff, or turbo bypass, valve has been added to the engines on the B-24N. The operation of this valve will require some study by the pilot before he becomes proficient in its use.

Generally speaking, the B-24N is much more of a pilot's airplane and the average pilot will find much less difficulty when flying under unbalanced power conditions.

RESTRICTED



## B-24N

INSTRUMENT PANEL

AND

CONTROL PEDESTAL

SECTION OF MAJOR

CHANGES SHOWN

IN RED

FOR FURTHER DETAIL

CONSULT T. O. AN 01-5EF-1

RESTRICTED

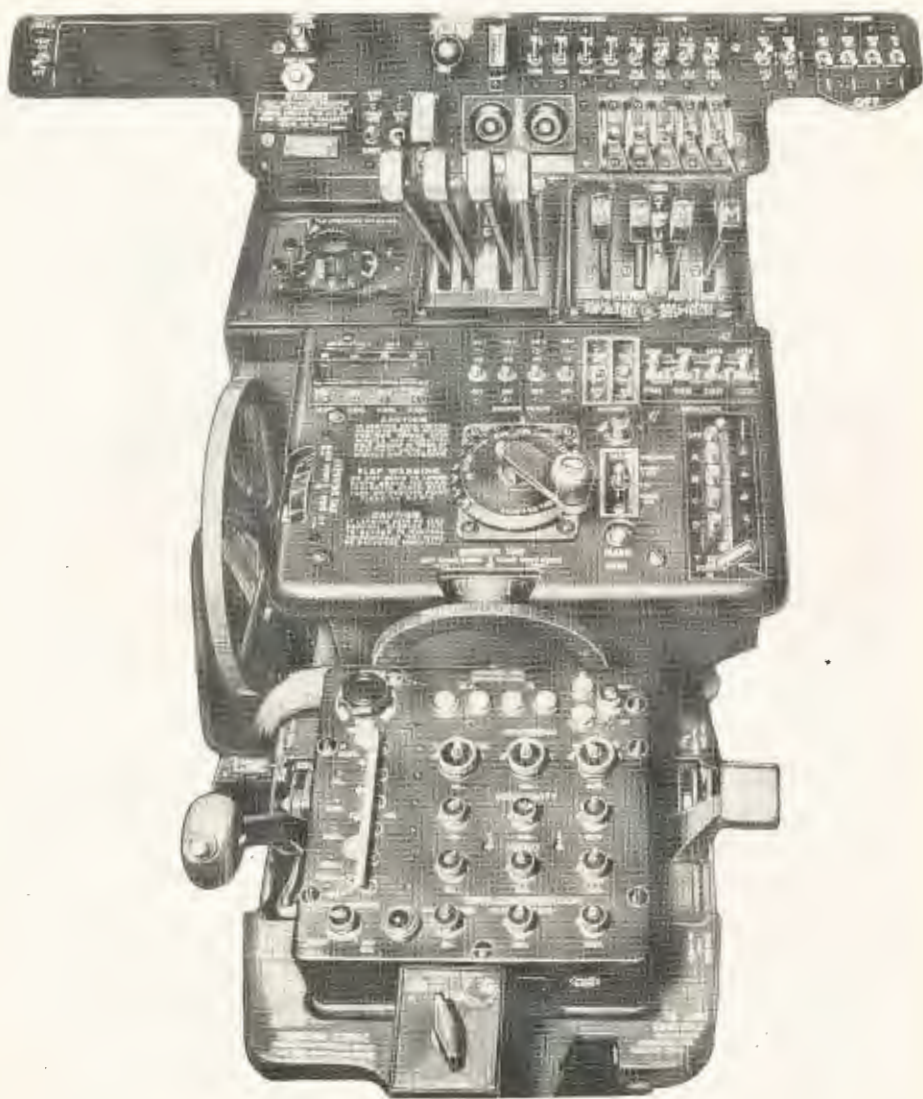

RESTRICTED

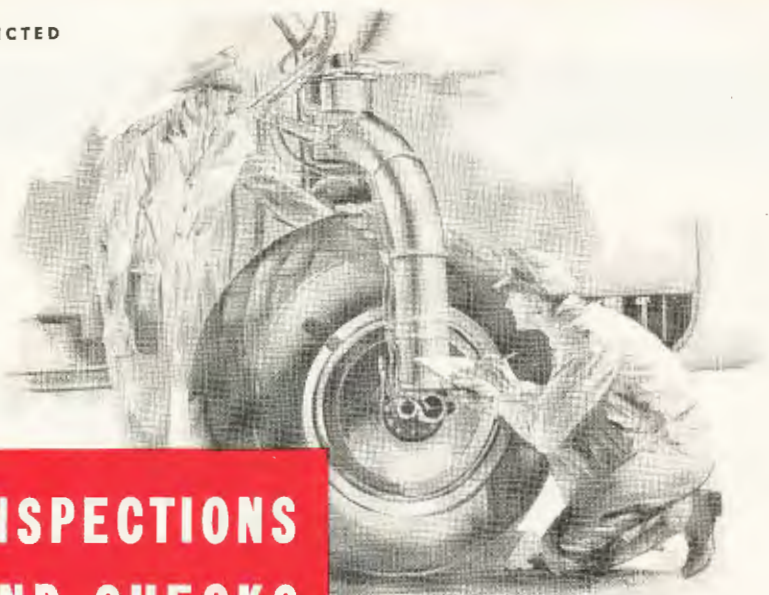

## INSPECTIONS AND CHECKS

As commander of a \$250,000 airplane, you can take nothing for granted. Satisfy yourself before every flight that your airplane is ready. One careless oversight can mean the failure of your mission. Think and act like an airplane commander from the moment you approach your airplane. This will inspire every member of your crew to work that much harder to demonstrate proficiency at his station.

### EXTERNAL VISUAL INSPECTION

Your first act upon approaching the airplane is to inspect the crew, making sure that every man is properly equipped and ready for the mission. After depositing your equipment in the airplane, execute the external inspection. Be businesslike and thorough. Keep in mind

that flying gravel, a passing vehicle or that last hard landing may have weakened your airplane. You are double-checking to see that the engineer has done his job properly.

#### **DANGER**

**Never allow anyone, under any circumstances, to walk through the propellers or between the fuselage and propellers even though the engines are not running. This is an ironclad rule that every airplane commander is bound to observe and enforce. If you are lax and set a bad example when there is no danger, it may someday cost you an absent-minded crewman.**

#### **Sequence**

The fastest, most efficient way to inspect your airplane is to follow a definite, prescribed sequence every time. Always start at the right side of the fuselage, proceed out along the right wing and around its tip (to avoid walking through the propellers) and continue on around the airplane to the starting point. **This check requires only 5 minutes.**



## SEQUENCE FOR EXTERNAL CHECK

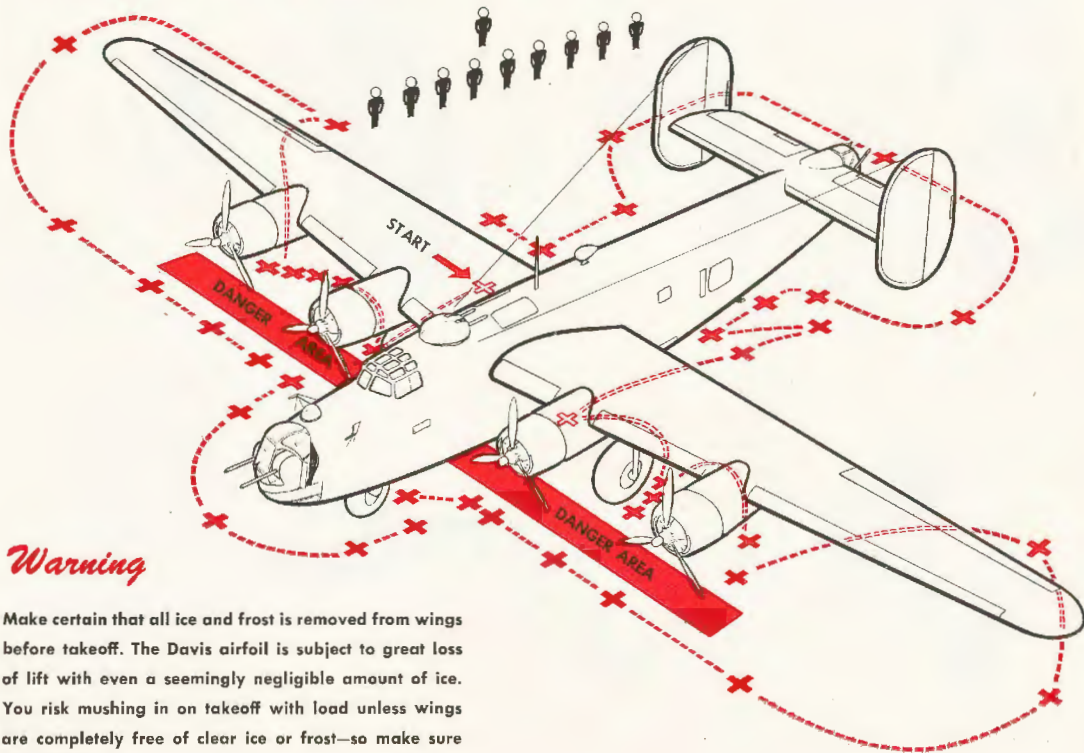

### *Warning*

Make certain that all ice and frost is removed from wings before takeoff. The Davis airfoil is subject to great loss of lift with even a seemingly negligible amount of ice. You risk mushing in on takeoff with load unless wings are completely free of clear ice or frost—so make sure they are clean!



1. **Fuel Cell Area:** Inspect fuel cell area of wing, between gear and fuselage, for security of inspection plates and for leaks.



3. **No. 3 Supercharger:** Check for free movement of bucket wheel, alignment and warping of buckets, and for missing or cracked buckets. Check the exhaust section for cracks or loose joints. Check the waste gate for full open position and free movement.

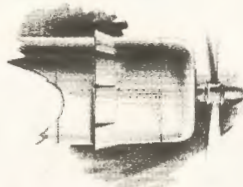

4. **No. 3 Nacelle:** Check for loose cowl fasteners or damage.

5. **No. 4 Supercharger:** Same check as for No. 3.

6. **No. 4 Nacelle:** Same check as for No. 3.



2. **Right Main Gear:** Check for proper inflation, cuts or bruises, tire slippage, and rim flange cracks. Oil leakage from the brake flange area usually indicates a ruptured brake expander tube. Inspect hydraulic lines and fittings for security and leaks, and check oleo strut for  $3\frac{1}{2}$ -inch extension. Check down-latch in position and undamaged. Check point of suspension of landing gear for cracks and buckling. A faulty gear may let you down hard.



7. **Right Aileron:** Inspect aileron for condition of fabric. (Check trim tab for damage.)



8. **Right Outer Wing Panel and Running Lights:** Check condition of wing panels, and check lights for breakage or dirt.

9. **Right Outboard De-icer Boot:** Inspect for cracks or damage.



10. **No. 4 Engine:** Inspect nose section for oil leaks or foreign matter wedged between cylinders. Check propeller for cracks, and anti-icer slinger ring for security. Inspect propeller governor connections.

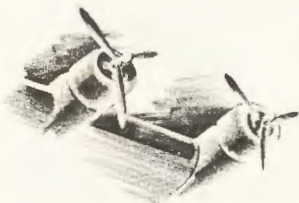

11. **De-icer Boot Between Engines:** Check for cracks or damage.

12. **No. 3 Engine:** Same check as for No. 4.

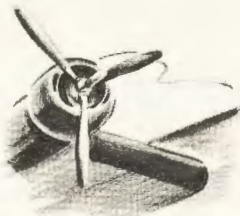

13. **Right Inboard De-icer Boot:** Check for cracks or damage.

14. **Right Pitot Tube:** Check pitot head cover; if it is not removed your bombardier's airspeed indicator won't work. (New G-2 pitot-static system has only one pitot tube, on lower left side of the nose.)

RESTRICTED

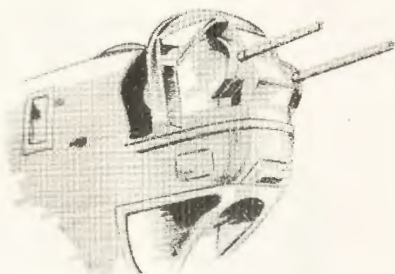

15. **Nose Turret:** Make sure that nose turret is locked in forward position and free from damage.



16. **Left Pitot Tube:** Same check as for right tube, to insure operation of pilot's airspeed indicator.

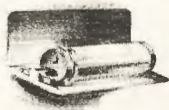

17. **Fire Extinguisher:** Open small access door in fuselage on left side of nose and check fire extinguisher for proper stowage. Reclose door securely.

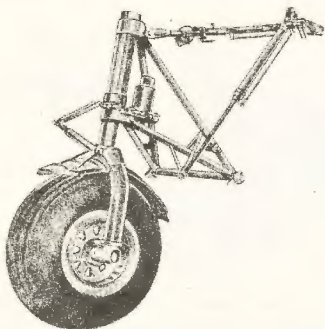

18. **Nosewheel Assembly:** Check tire for proper inflation, cuts, bruises, blisters, excessive wear, and slippage. Have tire inspected at once if it has slipped. Check oleo strut for  $4\frac{3}{4}$ -inch extension. Pressure gage on shimmy damper accumulator should read 250 lb. sq. in. If it is a Houdaille type shimmy damper (which has no accumulator), check the needle plunger at top of damper assembly for  $\frac{3}{8}$  to  $\frac{5}{8}$ -inch extension. Check nose gear down-latch in the down position. Check nose assembly hydraulic lines and fittings for leaks.

19. **Left Inboard De-icer Boot:** Check for cracks or damage.

20. **No. 2 Engine:** Same check as for No. 3.

21. **De-icer Boot Between Engines:** Check for cracks or damage.

22. **No. 1 Engine:** Same check as for No. 2.

23. **Left Outboard De-icer Boot:** Check for cracks or damage.

24. **Left Outer Wing Panels and Running Lights:** Same check as for right wing—panels for condition, lights for breakage or dirt.

25. **Left Aileron:** Inspect for fabric condition.

26. **No. 1 Nacelle:** Same check as for No. 4.

27. **No. 1 Supercharger:** Same check as for No. 4.

28. **No. 2 Nacelle:** Same check as for No. 1.

29. **No. 2 Supercharger:** Same check as for No. 1.

30. **Left Main Gear:** Same check as for right main gear.

31. **Fuel Cell Area:** Same check as for right side.



32. **Left Wing Flap:** Check flap for proper alignment with trailing edge of wing, in full up position and free from skin damage, holes, or dents.



33. **Antenna:** Check for security.



34. **Ball Turret:** Make sure turret is locked in up position.



35. **Tailskid:** Check for full extension and freedom from damage; check hydraulic fittings.



36. **Left Waist Door Wind Deflector:** Check—securely closed.

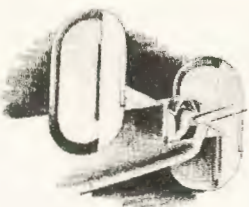

37. **Left Tail Section:** Check de-icer surfaces. Check stabilizer surfaces for loose rivets and buckling of plates. Check left fin, rudder, elevator, and trim tab for alignment and condition of fabric.

38. **Tail Turret:** Check for alignment and security.

39. **Right Tail Section:** Same check as for left side.

40. **Right Waist Door Wind Deflector:** Check—securely closed.

41. **Fire Extinguisher:** Check stowage of fire extinguisher in fuselage position just aft of rear bomb bay.

42. **Right Wing Flap:** Same check as for left wing flap.

---

Reject the airplane if you discover unsafe defects, and list all defects on Form 1A. Also report all defects to your crew chief.

---

You should have made a complete circuit of the airplane without once walking through the propellers. You are now ready to enter the bomb bay for the internal inspection. Before you do, however, check one final item:

**Pulling Through Engines:** Check that each engine has been pulled through 6 blades to assure free turning of the engine and to detect any oil or fuel in the combustion chambers which would damage the engine.

### *Danger*

Before the engineer approaches engines, check the ignition switches and the master ignition switch "OFF." See that the engineer stays clear of the propeller plane of rotation. A broken wire or a hot plug might cause a kickback and serious injury.

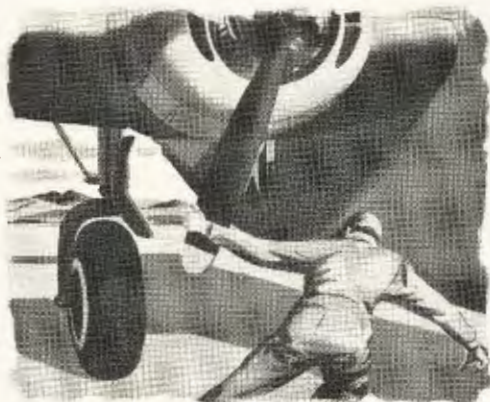

## INTERNAL VISUAL INSPECTION

The internal visual inspection is just as important as the external inspection. Keep your crew conscious of the fact that you are vitally interested in the condition of every part of the airplane. Don't tolerate rubbish or improperly stowed cargo or equipment. But be quick to praise the well-kept airplane. Execute the interior inspection in the following sequence:

1. **Rear Section of Fuselage:** Upon entering the bomb bay doors proceed to the rear and inspect location and anchoring of cargo, gear, guns, and ammunition.

2. **Hydraulic Reservoir:** Check for leakage. Should be filled to within  $\frac{1}{2}$  inch of red line on reservoir gage, provided the accumulators are properly charged. Check hydraulic reservoir emergency suction valve in horizontal position.

3. **Emergency Hydraulic Star Valve:** Check in the closed position and safety wired.



4. **Fuel Selector Valves:** On your way to the flight deck check each of the 4 fuel selector valves set in tank-to-engine positions, i.e., No. 4 tank to No. 4 engine, No. 3 tank to No. 3 engine, etc., to make sure that each engine is receiving fuel from its main fuel cells only. Two of these valves are mounted inside the fuselage on each side of the bomb bay overhead between the wing spar and Station 4.2. (On late-model planes, fuel selector valves are on the flight deck.) The 2 valves on the right control the flow to engines No. 3 and No. 4, and those on the left control the flow to engines No. 1 and No. 2, as numbered.

**Caution:** Should the 4 main tank selector valves be set at "1, 2, 3, and 4 TANK to No. 1,

2, 3, and 4 ENGINE and CROSSFEED," a failure of any fuel line or the crossfeed manifold would result in a loss of both fuel and fuel pressure. On takeoff this would be disastrous.

5. **Fuel Sight Gages:** As you enter the flight deck, check the quantity of fuel aboard using the gages on your left. Each gage is connected by a 2-way valve to 2 of the 4 main fuel systems as labeled. For gages to give an accurate reading, the inclinometer located outboard of the gages must be centered.

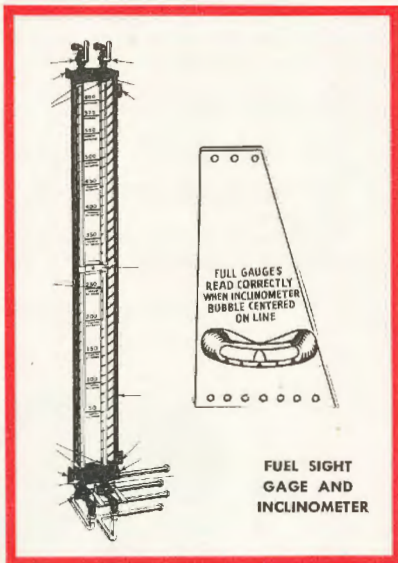

6. **Flight Deck:** Check placing of gear, movable equipment secured in proper places, windows clean, etc.

7. **Personnel:** Satisfy yourself that all persons are aboard, are properly clothed for the mission, are equipped with a parachute and oxygen mask, and understand their use. Be sure sealed first-aid kits are in their proper locations. Make sure there is ample oxygen aboard at all stations for the mission planned. Check to see that all personnel know the emergency warning signals for bailout and ditching

and the procedures to be followed, and that they know their stations for takeoffs, flight and landings. See that a loading or passenger list has been sent to Operations if required.

8. **Maps and Navigational Aids:** Make sure that necessary up-to-date maps, copies of instrument procedures, radio facility charts, radio aids to navigation and direction-finding charts are aboard.

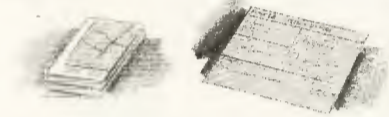

9. **Form 1A:** Before you accept the airplane, study Form 1A and note all defects, comments of pilots and notations by crew chief of work done on the airplane since the last flight.

10. **Loading:** Ascertain that the airplane is properly loaded within the allowable center of gravity (CG) limits by checking Form F in "Weight and Balance Data" in the airplane.



11. **Seating:** After these things have been accomplished, the pilot and copilot are ready to get into their seats, fasten safety belts, and adjust the seats and foot pedals to permit full

rudder and brake control. The levers on the seat permit adjustment fore and aft, up and down, and tilt. To adjust rudder pedals, push the pedal adjustment lever away from the pedal with the toe and move the pedal fore or aft. **Be sure the catch relocks properly.**

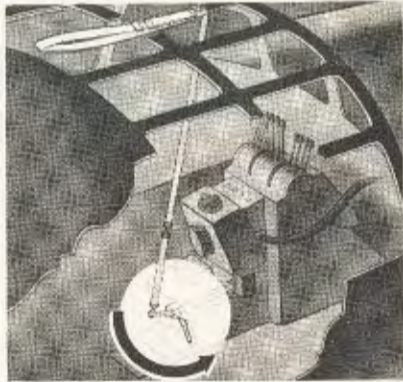

12. **Unlocking Controls:** Copilot unlocks controls, securely stows the strap overhead so it won't bang the pilot in the face, and checks the locking lever in the full down position to make sure the lock is released. Then you are ready to start the checklist procedure.

**Wait:** Is everyone aboard? Is all equipment aboard? Is the fuel supply ample? It is always embarrassing to have to return to the line, to bail out without a parachute, or to arrive over the target without your bomb load.



# THE CHECKLIST

No pilot (in his right mind) neglects the checklist in a 4-engine airplane. Your mission, your airplane and your crew are too important for half-measures. No pilot can ignore the checklist on flight after flight without getting into serious trouble. A big-shot attitude toward the checklist is risky and sets a bad example for your copilot and your crew. To old-time B-24 pilots, who have been through the mill, the checklist is as vital a piece of equipment as the rudders or the flaps.

### Approved Checklist Technique

Develop a professional teamwork technique in using the checklist so that you and your copilot are double-checking each other all the time. Require complete cooperation from your copilot and engineer. Sloppy crew work is usually a direct reflection of the attitude of the airplane commander. Following is approved checklist technique:

1. Pilot calls, "Checklist!"
2. Copilot picks up the checklist and holds it throughout the procedure.
3. Copilot calls out each checklist item in

sequence, in a loud, clear voice, and indexes the list with thumb or finger to be sure nothing is omitted.

4. Pilot, copilot or engineer makes a positive check of the item when it is called out and calls back the answer.

## Caution

Never start on the next checklist point until the preceding one is completed, or the result will be confusion and omissions. **Believe and practice this.** Don't wait for bitter experience to prove it. Never say "Okay" without checking. Sloppy use of the checklist is responsible for more emergencies than almost any other form of pilot error.

### Snap Into It

Get some snap into the checklist procedures. Alert, professional cockpit work with items called off and answered in clear, ringing tones will lift the spirits of your crew and get them on the ball just as a good quarterback's signals bring his team to life.



## BEFORE STARTING ENGINES

Following are the cockpit duties and checklist points for the before-starting check.

### Amplified Checklist

#### 1. Copilot: "FORM 1A?"

Pilot: "Form 1A checked!"

Pilot's reply indicates that he has completed the required preflight inspection of Form 1A.



#### 2. Copilot: "LOADING?"

Pilot: "Loading checked!"

Pilot's reply indicates that he has completed the preflight requirements for proper loading.

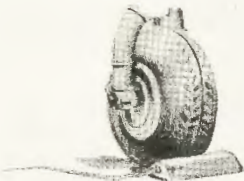

#### 3. Copilot: "WHEEL CHOCKS?"

Each pilot checks the chock on his side. Chocks should not be against the tire but should be 2 to 6 inches forward of the wheel. Parking brakes will normally hold the airplane. Chocks may become jammed under the tires if placed against them.

Pilot: "Wheel chock in place left!"

Copilot: "Wheel chock in place right!"

RESTRICTED

#### 4. Copilot: "PITOT COVERS?"

Each pilot looks at the pitot head on his side of the airplane to be sure the pitot covers have been removed.

Pilot: "Removed left!"

Copilot: "Removed right!"

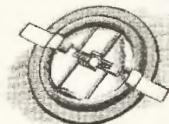

#### 5. Copilot: "GAS TANK CAPS?"

Security of caps is vitally important. If a gas tank cap isn't properly seated, gas may be syphoned out by the suction on top of the wing, rapidly emptying your tanks. Some of this gas will usually run back through the wing into the bomb bay, creating a dangerous fire hazard.

Engineer: "Gas tank caps checked!"



#### 6. Copilot: "FLIGHT CONTROLS?"

Pilot and engineer check all controls. Engineer puts his head out the flight deck escape hatch to watch control surfaces. The pilot moves controls to extreme positions calling out each set as he operates them.

Pilot: "Controls checked visually!"

Example: As the pilot moves the wheel full back he calls out, "Elevators," and the engineer replies, "Elevators up." As the pilot moves the wheel full forward the engineer calls out, "Elevators down." The check continues: "Rudders"—"Rudders right," . . . "Rudders left" . . . "Rudders neutral,"—"Ailerons"—"Right aileron down, Left aileron up," . . . "Right aileron up, left aileron down."

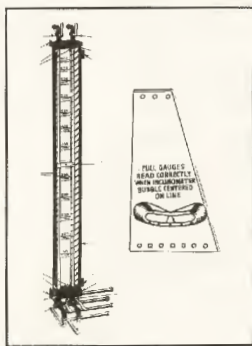

7. Copilot: "FUEL TANK VALVES AND AMOUNT?"

Engineer: "Checked . . . (number) gallons of gas and . . . (number) gallons of oil aboard."

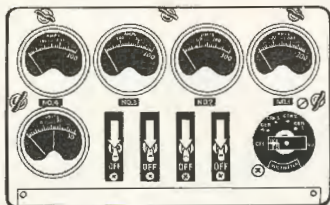

8. Copilot: "GENERATORS?"

Copilot and engineer look back to check generators in "OFF" position. Generators are kept off until just before takeoff to prevent drain of battery current back to generator in case of faulty reverse current relay and because generators will not charge unless rpm is 1700 or more.

Engineer: "Generators off!"

9. Copilot: "CARBURETOR AIR FILTERS?"

In absence of dust and blowing sand, carburetor air filters are always kept closed. Engineer sets them as directed for local conditions.

Engineer: "Carburetor filters (as required)."

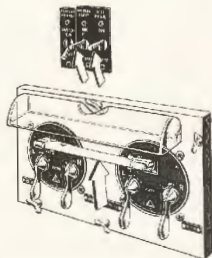

10. Copilot: "MAIN LINE AND BATTERY SELECTORS?"

Copilot turns on these switches and checks each battery selector separately by referring to the voltmeter reading to determine the battery condition. If the battery cart is used to start engines, turn on the main line switch but leave the battery selectors off. This directs current from the battery cart through the main line bus and prevents drain of the plane's batteries.

Copilot: "Main line and battery selectors on!"

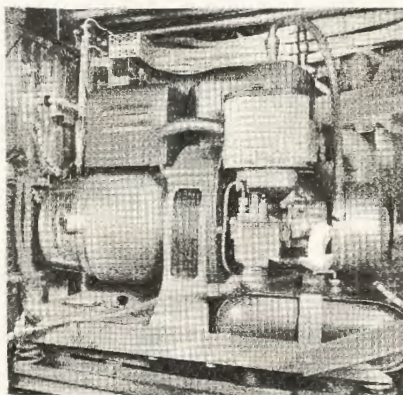

11. Copilot: "AUXILIARY POWER UNIT AND HYDRAULIC PUMP?"

The engineer starts the auxiliary power unit and turns on the hydraulic pump. The pump

cuts in to charge accumulators when the pressure drops below 975 lb. and cuts out at 1180 lb. When No. 3 engine is operating, the engine-driven pump charges accumulators through the unloading valve when pressure drops below 850 lb., and cuts out at 1050 lb.

Engineer: "Auxiliary power unit and hydraulic pump on."

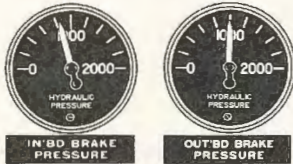

**12. Copilot: "BRAKE PRESSURE AND PARKING BRAKE?"**

The pilot applies the brakes, checks the inboard and outboard brake pressure gages at 975 lb. to 1180 lb. and sets the parking brake.

Pilot: "Pressure checked and parking brake on!"

To set the brake, hold the brake pedals down, raise the parking brake handle and then release the brake pedals. Never force the handle either up or down or you will snap the locking pin.

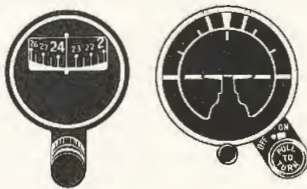

**13. Copilot: "GYROS?"**

Pilot uncages the directional gyro and the flight indicator. Then, when the engine that provides suction is started (No. 1 or 2), the speed with which the flight indicator rights itself indicates its reliability. (Note: Jack and

Heintz indicators must be uncaged and manually righted after engines are started.)

Pilot: "Gyros uncaged."

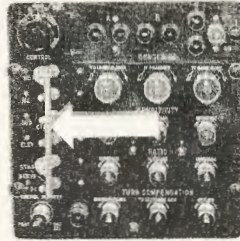

**14. Copilot: "AUTOMATIC PILOT?"**

Pilot checks all switches on the automatic pilot in "OFF" position. If you attempt a take-off with this unit connected, it is extremely difficult to overpower it.

Pilot: "Automatic pilot off!"

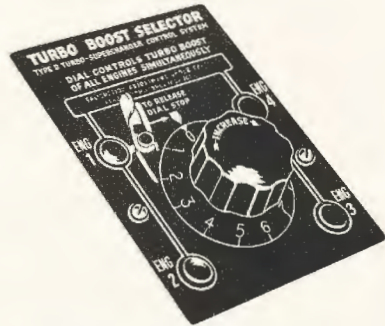

**15. Copilot: "SUPERCHARGERS?"**

Pilot checks all superchargers in "OFF" position. Superchargers should have been left off when the engines were last stopped so that waste gates are open. If waste gates are closed when you start the engines, the exhaust system or the turbo may be damaged by the excessive exhaust pressure. With electronic turbo control, set dial at zero.

Pilot: "Superchargers off!"

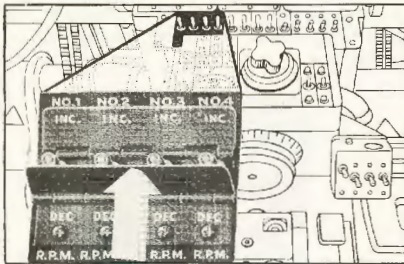

16. Copilot: "PROPELLERS?"

Copilot holds propeller toggle switches forward to "INCREASE" rpm. If governor limit lights come on, propeller governors are set for full high rpm.

**Copilot: "Props in high rpm!"**

**Caution:** Be sure to move toggle switches forward; governor limit lights will also come on when toggle switches are moved back, and this would set the governor for full low rpm.

17. Copilot: "ALARM BELL?"

Pilot gives the normal abandon-ship signal, listening for the bell himself as he does so, and each crew member replies by interphone that he has heard the bell.

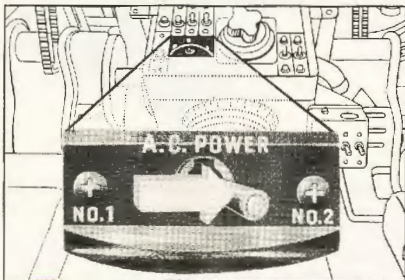

18. Copilot: "AC POWER SWITCH"

Copilot moves this switch to No. 2 inverter and checks it by switching on one booster

pump and noting a rise in fuel pressure on the corresponding fuel pressure gage. He then flicks off the booster pump, moves the AC switch to neutral, switches to No. 1 inverter and again uses the booster pump check.

**Copilot: "AC power on and checked!"**

Use the No. 1 inverter and save No. 2 as an alternate, emergency position. It is bad practice to switch back and forth between inverters.

**Note:** On some late series aircraft an automatic change-over relay is installed which switches from No. 1 to No. 2 inverter if No. 1 fails, and a red light on the instrument panel warns you that No. 1 is dead. The toggle switch is still used for checking inverters.

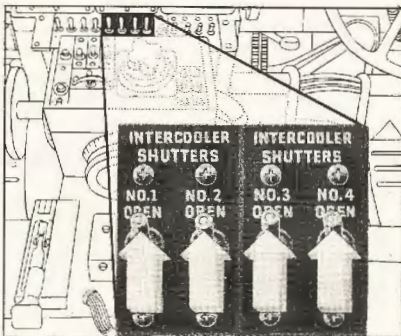

19. Copilot: "INTERCOOLERS?"

Copilot checks intercooler shutters in open position which is normal.

**Copilot: "Intercoolers open."**

There is no advantage in closing intercooler shutters. If closed, they may cause overheating and detonation on takeoff. Check the proper operation of shutters by listening to each motor while moving switches to closed and back to open positions. If the motors cannot be heard, the engineer or a member of the ground crew should check shutters in operation, checking them in the open position.

## 20. Copilot: "PITOT HEATER?"

Copilot flicks switch on and off while looking back at voltmeter for a flicker indicating current drain. The only accurate check is for the engineer to feel the pitot tube heat during his preflight.

Engineer: "Pitot heaters checked!"

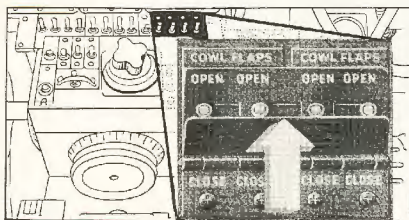

## 21. Copilot: "COWL FLAPS?"

Copilot opens them and checks them on the right while the pilot checks them on the left. Cowl flaps are open while starting to help keep the engine cool and to facilitate putting out fires from the outside.

Caution: Never close cowl flaps to hurry warm-up because this will damage the ignition harness, especially at the spark plug elbows, by excessive heating.

Pilot: "Cowl flaps open left!"

Copilot: "Cowl flaps open right!"

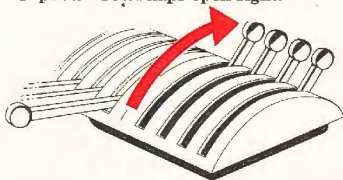

## 22. Copilot: "MIXTURE CONTROLS?"

Copilot checks mixture controls forward in "IDLE CUT-OFF." Otherwise blower section will be flooded when booster pumps are turned on, creating a fire hazard and making starting difficult.

Copilot: "Mixtures in idle cut-off!"

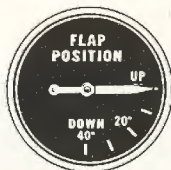

## 23. Copilot: "WING FLAPS?"

Copilot checks that the flap control handle is in the neutral position and that the flap indicator shows flaps are up.

Copilot: "Wing flaps up!"

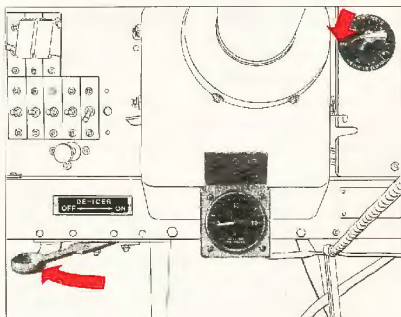

## 24. Copilot: "WING DE-ICERS; PROPELLER AND CARBURETOR ANTI-ICERS?"

Copilot checks each in "OFF" position. This is vital. Even partial inflation of the wing de-icer boots reduces lift and increases the stalling speed. When on, propeller anti-icers will pump fluid on the ground and carburetor anti-icers (if so equipped) will pump fluid into the carburetors, enriching the mixture.

Note—If exhaust heat anti-icing is installed, the cabin heat or anti-icing switches may be on if desired.

Copilot: "All de-icers and anti-icers off!"

As soon as the before-starting check is completed, you are ready to start engines.

# STARTING ENGINES

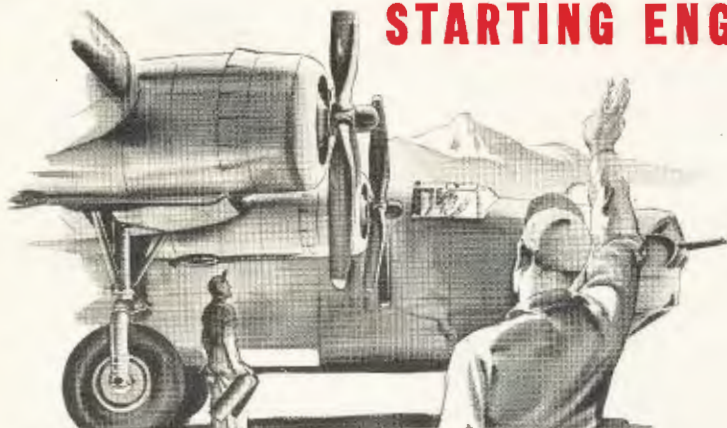

Step-by-step precision in starting engines is the mark of a top-notch military pilot. There is a best way to do everything. Learn and perfect the best starting procedure and it will help to eliminate errors. Use the checklist procedure.

It is the airplane commander's responsibility to see that engineer and ground crew understand the standardized precautions for starting engines. These require one man posted as fire guard at the engine being started and a second man in view of personnel in the cockpit to relay signals to the fire guard.

## Amplified Checklist

### 1. Copilot: Call "CLEAR!" Fire Guard Posted

Copilot and pilot stick their heads out of their windows to check personnel and shout, "Clear!" Copilot checks that a fire guard is posted and holds up three fingers to indicate that he will start No. 3 engine first.

#### Copilot: "All clear and guard posted!"

Start engines in sequence 3, 4, 2, 1, to keep guard from running through an outboard prop in case of fire and because the engine-driven hydraulic pump operates off No. 3 engine. When engines are energized exter-

nally, start in sequence 1, 2, 3, 4, to keep the ground-crew man safely clear of propellers.



### 2. Copilot: "IGNITION SWITCHES?"

Copilot turns on the ignition switches for all 4 engines.

Copilot: "Ignition switches all on!"

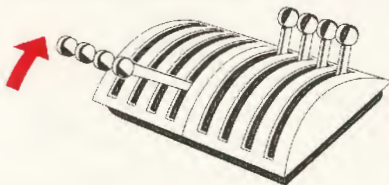

### 3. Copilot: "THROTTLES?"

Pilot moves all throttles to cracked position, approximately  $\frac{1}{2}$  open. This prevents excessive backfiring and overspeeding of engine on starting.

Pilot: "Throttles cracked!"

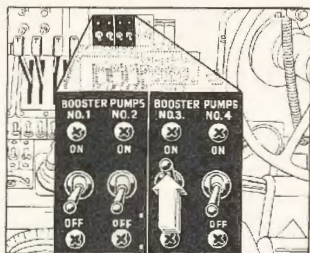

4. Copilot: "BOOSTER PUMP?"

Copilot turns the booster pump on for the engine to be started to supply fuel pressure for priming and notes pressure, usually about 8 lb.

Copilot: "Booster pump on!"

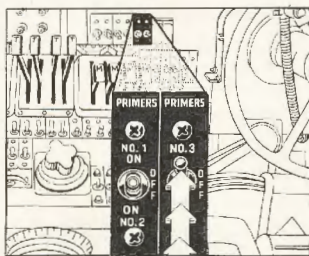

Priming

Engine may be primed when fuel pressure is above 4 lb. Copilot primes by pressing the primer switch for one second and then releasing it. The number of one-second shots will normally be not less than 3 nor more than 6 depending on the temperature of the engine and the outside air. This drives the fuel into the engine intake in spurts. Do the priming while you are energizing.

Two Types of Starters

Energizing time will vary with the 2 types of starters in use on B-24's. The old type requires 30 seconds. Switch is moved up to "START" for energizing and down to "MESH." Energizing stops when the switch is on "MESH." In the new-type starter there are separate

switches for energizing and meshing. Move first switch up to "ACCEL" to energize for 12 seconds and keep it there while you move the second switch to "MESH." Thus the energizing continues during the cranking or meshing. Some nameplates are marked "CRANK" instead of "MESH."



Old Type

New Type

5. Copilot: "START ENGINES."

a. While priming with one hand, copilot energizes starter with the other hand for required number of seconds.

b. Copilot meshes starter and holds it meshed until the engine is definitely started because the booster coil or induction vibrator is hooked up to the meshing switch. If the engine doesn't start immediately, use more priming.

c. As soon as the engine fires, the pilot brings mixture control back to "AUTO-RICH" and leaves it there.

d. Copilot turns the booster pump off.

e. Copilot watches the oil pressure gage and calls out, "Oil pressure coming up," if it is. If oil pressure does not rise within 30 seconds, copilot puts mixture control in "IDLE CUT-OFF" and stops the engine. During the first 30 seconds of firing hold rpm as low as possible.

Copilot: "No. 3 started."

(Successive engines are started in the same manner.)

Warm-Up

Throughout the warm-up and other ground operations, when not actually taxiing, idle the engines at 1000 rpm. Warm-up should continue until the oil temperature indicators for all engines reach 40°C, minimum, and until cylinder-head temperatures reach 120°C.



#### 6. Copilot: "FLIGHT INDICATOR?"

When No. 2 or No. 1 engine (whichever is supplying the vacuum) is started, pilot checks the speed and precision with which the flight indicator rights itself. If righting action is sluggish, the instrument needs repair. (Note: Jack and Heintz Flight Indicators Model JH 6500 must be left caged until the engine has been running for 5 minutes to allow rotor to gain full speed. Then uncage and check to see that it does not spill.)

#### If an Engine Stops

If an engine stops, immediately put mixture control in "IDLE CUT-OFF" and repeat entire starting procedure. If the propeller starts turning when you re-energize, release the energizing switch and cut the ignition switch "OFF." Then have a crew member rock the propeller to disengage the starter dogs.

#### If an Engine Is Flooded

If an engine becomes flooded, put the mixture control in "IDLE CUT-OFF" and open throttle fully until excess gasoline is cleared out and the engine begins to fire. Then immediately retard the throttle to  $\frac{1}{2}$  open and move mixture control to "AUTO-RICH."

#### If an Engine Won't Mesh

If an engine won't mesh or crank, and you want manual meshing, notify the man in front of the airplane by raising a clenched fist and pulling sharply downward. He will use the same signal to notify the fire guard who will then pull the manual meshing handle. The mesh switch on the copilot's panel should be used when meshing manually, even though it is apparently not working, since it also completes the circuit to the booster coil or induction vibrator.

When all engines are started and warmed up, you are ready to begin the before-taxiing check.

## BEFORE TAXIING

### Amplified Checklist

Make a careful check before you start taxiing to make sure your engines, instruments, and radio are operating properly. All of the readings given below are maximum and minimum limits based on rpm of 1000.



#### 1. Copilot: "ALL INSTRUMENTS?"

Directional gyro. Pilot pushes caging knob to caged position, spins and quickly uncages. Indicator should stop moving when uncaged. If it continues to spin, gyro requires repair. Try it both ways, left and right.

Pilot: "Directional gyro checked!"

Copilot checks the following:



a. **Manifold Pressure.** Check for steady indication. Erratic reading indicates defective instrument.



b. **Tachometer.** Check for steady indication at 1000 rpm.



c. **Fuel Pressure.** Should read 16 to 18 lb.





d. **Oil Pressure.** Should read 45 to 100 lb. Low reading may indicate oil shortage or pump failure.



e. **Oil Temperature.** Limits are 40° to 100°C. Desired range is 60° to 75°C.



f. **Cylinder-Head Temperature.** Limits are 120° to 232°C for ground operation. Do not operate above 1000 rpm until head temperature is 120°C or more.

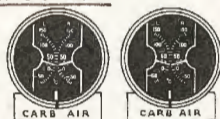

g. **Carburetor Air Temperature.** If there is high humidity, ice may form during ground operation if carburetor air temperature is below 15°C. Best operating limits are between 15°C and 35°C. Above 35°C there is likely to be detonation.



h. **Hydraulic Brake Accumulator Pressure.** Check inboard and outboard gages indicating between 975 to 1180 lb. **Don't start taxiing if either gage falls below 950 lb.**

For an additional check on the hydraulic system, put the flap control handle in the "UP"

position; if it kicks out, the free-flow system is operating properly.



i. **Gear Warning Light.** Should be lighted.



j. **Free Air Temperature.** Check against temperature you obtained in the weather office. You'll need this gage to anticipate icing conditions.

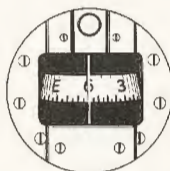

k. **Compass.** Check deviation card—in place and up to date.

Copilot: "All instruments checked!"



2. Copilot: "VACUUM?"

Engineer calls out No. 1 or No. 2 engine, (whichever is supplying vacuum). Pilot checks his gage and, if gage registers between 3.75 and 4.25, calls "Checked." Engineer turns the vacuum selector valve to the other engine and the procedure is repeated. Valve should be turned to No. 2 after the check is completed.

Pilot: "Vacuum checked on Nos. 1 and 2!"



3. Copilot: "RADIO, ALTIMETER, TIME."

Copilot calls the tower for radio check, altimeter setting and correct time.

a. Radio check has three elements: (1) Frequency: on frequency, or one or more kilocycles low or high; (2) Readability, R . . . 1 to 5; (3) Signal strength, S . . . 1 to 5. Desired check is "On frequency, R5, S5."

Copilot: "Radio checked!"

b. Altimeter setting. Pilot sets altimeter at barometric pressure and notes difference between altimeter reading and actual field altitude. Maximum error permissible is 50 to 75 feet. Pilot then re-sets altimeter at actual field elevation and notes error in barometric reading. Thus, if the tower gives a reading of 29.20 but altimeter reads 29.25 when set at correct field elevation, .05 should be added to any barometric reading obtained during the flight. As a rule-of-thumb guide only, .01 difference in barometric reading equals 10 feet altitude.

Pilot: "Altimeter set."

c. Time. Copilot checks cockpit clock time against tower report.

Copilot: "Time checked."



4. Copilot: "WHEEL CHOCKS?"

Pilot and copilot look out their windows to check chocks removed.

Pilot: "Wheel chock removed left!"

Copilot: "Wheel chock removed right!"

Note: If the airplane is equipped with electronic turbo control, always keep the dial set at zero for taxiing.

ALWAYS USE AUTO-RICH FOR ALL  
GROUND OPERATION

## TAXIING



Nothing makes a pilot and his crew feel more foolish than a taxiing accident that does several thousand dollars worth of damage. Clumsy taxiing imposes severe strains on the nose gear, main gear, tires and other parts of the airplane, and negligence in taxiing will not be tolerated. Smooth, skillful taxiing technique is a must for 4-engine aircraft. When all checklist items through "Before Taxiing" are completed, and you have radio approval from the tower, you are ready to start taxiing. Check to make certain that your seat is well forward so that you are in a position for full rudder and brake control.

### Position of Feet

The position of your feet is important. Set your heels on the rudder pedals with your toes well up above the brake pedals. **Always keep your toes off the brake pedals when not using the brakes.** Only slight pressure will build up tremendous friction and heat. Save your brakes for emergencies when you'll need them!



POSITION OF FEET WHEN USING RUDDER



POSITION OF FEET WHEN USING BRAKES

### Use of Rudder

When learning to taxi, hold rudders neutral because rudder control is ineffective except at excessive speeds. Also, when you are holding full rudder, right or left, it is difficult to use the brakes effectively. Ask your copilot to help hold rudders neutral and to check the neutral position as you taxi.

### Safety Observer

Post the engineer as observer with his head out the flight deck escape hatch to observe obstructions and signal "Clear left" and "Clear right." See that a ground-crew man is at each wingtip when taxiing in congested areas.

Be sure the nosewheel is straight. If turned more than 30°, it should be straightened with a bar. If you start taxiing with the nosewheel



turned, allow the airplane to roll a short distance in the direction it is turned and it will tend to straighten itself out. **Don't force the airplane straight ahead with power and brake against a turned nosewheel.**

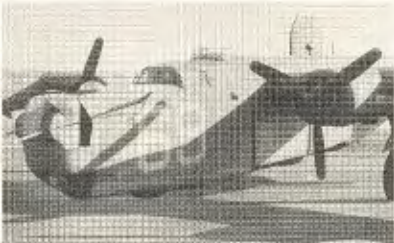

Results of Taxiing into Turned Nosewheel

### To Start Moving

Reduce power to idling, fully depress the brake pedals and release the parking brake handle. Then follow it up by hand to make sure it is released. Advance all throttles slowly and evenly until the airplane starts to roll. Don't use excessive power, and, as soon as the airplane is in motion, reduce the power.

### Use of Throttles

All 4 throttles are spring loaded, tending to hold higher rpm than idling. It is usually necessary to hold back pressure on the throttles to

## RESTRICTED

keep from overspeeding. Throttles tend to creep forward unevenly at low power settings. Frequently check the tachometer to maintain uniform power settings on all engines. Then you won't have to hold brakes against an overspeeding outboard engine to maintain directional control.

An expert at taxiing the B-24 can control it with throttles alone and without brakes. You can maintain speed equal to a brisk walk with 700 to 800 rpm on hard surfaces. If the airplane is easing to the right, add power to the right outboard engine but don't hold this power until the airplane swings back in line or it will swing past the desired point. Then you will have to add power on the left outboard and so on, building up excessive speed and S-ing. Develop an expert throttle touch.

The best way to hold throttles is palm down with the throttle knobs against the padded part of the palm, third finger-joints on top of throttles and fingers curled over them. The object is to be able to control any throttle separately.

### Turns

The B-24 is a big airplane. Get a mental picture of its radius of turn. The main gear at the inside of the turn is the turning point and it is far aft of your position in the pilot's seat. Your natural tendency is to turn too soon because you feel yourself going past the turning point.

On a left turn the pilot should watch the inside wheel; on a right turn the copilot should watch the inside wheel.

Note: You are controlling 20 to 30 tons of airplane and there is a delay between the application of power and the reaction of the airplane. Think and act ahead of the airplane and anticipate its delayed reactions.

### How to Turn

If the airplane is rolling at proper taxiing speed, no brakes are necessary to start the turn. Smoothly apply power to the outside engine to start the turn and remove power as soon as the airplane responds. Don't use excessive power. It is better to use too little throttle and then add more than to start too fast a turn and have to correct with the opposite outboard engine.

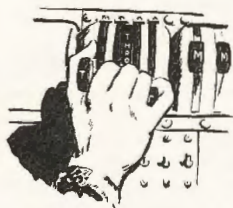

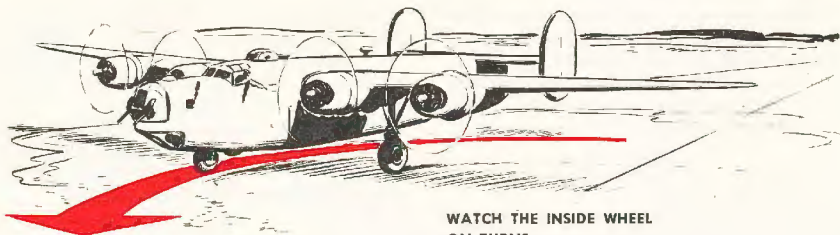

WATCH THE INSIDE WHEEL  
ON TURNS

This produces a seesawing action. If you build up excessive speed or turning action, throttle back, get control with the brakes and start over. Don't take a chance on dropping your airplane in a mudhole.

#### Don't Pivot

The most common error in turning is to pivot the airplane sharply. Don't brake the inside wheel to a stop and then pivot around it. This grinds the tire against the ground or cement, twisting the ply and weakening the tire.

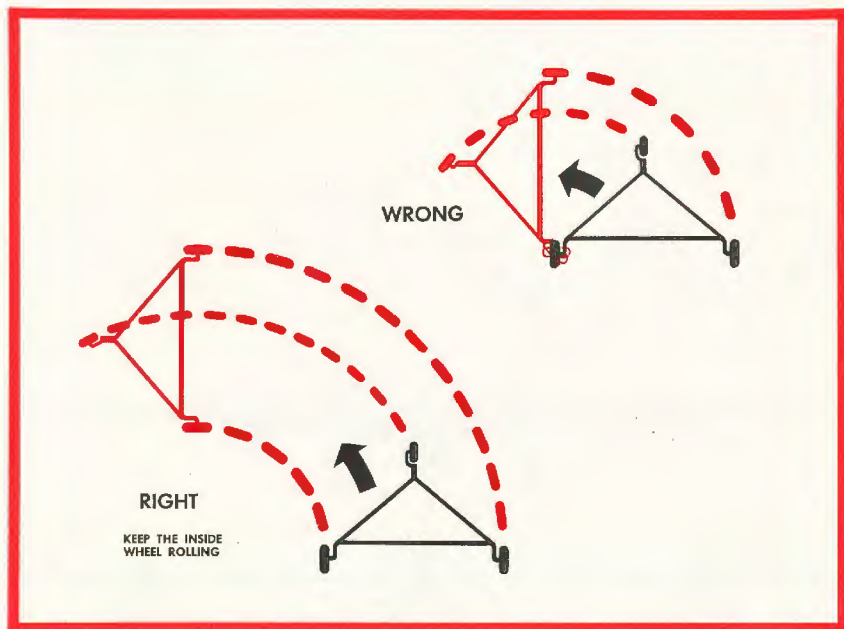

## RESTRICTED

Before starting to turn, when stopped, be especially careful to pick up forward motion and then to keep the inside wheel rolling steadily throughout the turn. Do not make short-radius turns because the nosewheel should never be turned more than 30° from the center line.

### Bank-and-turn Indicator

During turns while taxiing, make sure that the turn indicator is functioning properly, returns to neutral when the turn is completed and is not sluggish.

### Use of Brakes

Brakes should be applied with a smooth, steady build-up of toe pressure. Sudden application of the brakes slams the nose down, puts heavy strain on the nose and main gear assemblies, and may damage the brake expander tubes.

Require your copilot to check the accumulator pressure every 30 seconds and report "Pressure O.K." or "Pressure below 800 lb." If pressure drops below 800 lb., stop the airplane in its tracks and don't move it until the trouble is corrected. Always taxi with the auxiliary hydraulic pump on. It should cut in when pressure gets below 975 lb. and should maintain pressure at 975 to 1180 lb.

### Stopping

Always hold the airplane straight ahead when stopping so the nosewheel will be in the straight-ahead position. Apply sufficient brake pressure evenly to both brakes to slow the air-

plane. This will vary with the speed of the airplane and the distance available for stopping. As the airplane slows, release brake pressure gradually. If you hold a constant pressure the nose will snub down sharply, causing a jerky stop. With proper use of the brakes, you can bring the airplane to a full stop with no snubbing of the nose. Save the tremendous reserve power of your brakes for emergencies.

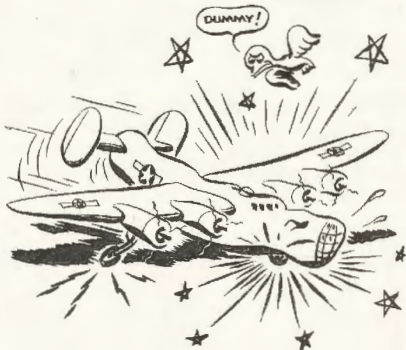

### It Takes a Lot of Room

The B-24 has 110 feet of wing span, as much as 3 P-40's taxiing wingtip to wingtip. Give it a lot of room.

Note: Taxi with all 4 engines running. If one propeller is feathered, the opposite engine may be cut for easier taxiing—but in no other case should engines be cut.

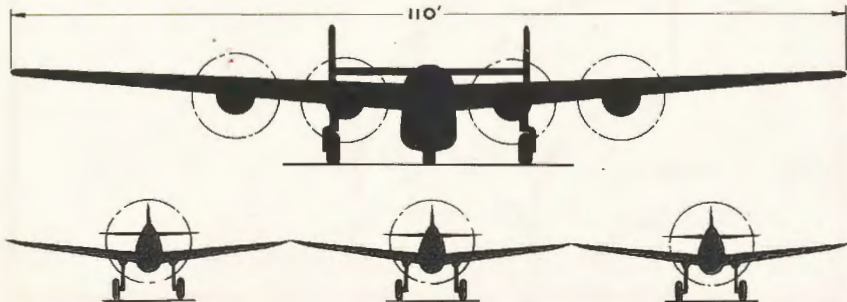



## ENGINE RUN-UP BEFORE TAKEOFF

Every airplane has its own peculiarities and its own personality. This is especially true in time of war when series, equipment, and number of hours in the air vary widely from plane to plane. The engine run-up before takeoff is your opportunity to feel out your airplane, judge its condition and note its peculiarities.

The B-24 blows a big breeze. Don't run up on the line unless local rules require it. Taxi to a point well clear of the takeoff runway (from which you can observe incoming traffic), and stop with the nosewheel lined up straight ahead. Fully depress the brake pedals, lift the parking brake handle to the locked position (do not force it), and release the brake pedals. This should lock the parking brakes. Set all throttles at 1000 rpm and faithfully follow checklist procedures during run-up.

### Crew Positions For Takeoff and Landing

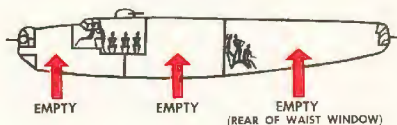

Be sure your crew know their positions for takeoff. No one should be in the nose compartment because of the danger of injury if the nosewheel should collapse. No one should be aft of the waist gunner positions because this materially changes the center of gravity and causes tail heaviness. No one should be in the bomb bay.

## RESTRICTED

Usual positions: Pilot, copilot, engineer, radio operator, navigator and bombardier on flight deck; gunners just aft of bulkhead No. 6.

Crew should not shift from their positions until the airplane is clear of the field and gear and flaps are up. At least one man in the rear compartment will be on interphone during taxiing, takeoffs and landings.

## BEFORE-TAKEOFF CHECK

### Amplified Checklist

#### \*1. Copilot: "TRIM TABS?"

Pilot sets these as desired (normally 2° to 3° right rudder, elevators 1° to 2° up, and



ailerons at 0°. The right rudder trim corrects for torque during takeoff.

Pilot: "Trimmed for takeoff!"

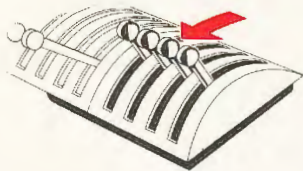

#### \*2. Copilot: "MIXTURES?"

Copilot checks to see that all are in "AUTO-RICH." **Danger:** Don't take off in "AUTO-LEAN" because there is danger of detonation or engine failure.

Copilot: "Mixtures in auto-rich"

\*ITEMS WITH ASTERISK FOR SUBSEQUENT TAKEOFF.



#### 3. Copilot: "EXERCISE PROPELLERS, TURBO-SUPERCHARGERS AND FLAPS!"

Pilot sets all throttles at 1500 rpm. Then copilot changes propeller governors from full high rpm to full low rpm and back, holding governor switches until propellers change all the way (all governor limit lights on at each extreme position); the pilot advances superchargers slowly and retards them slowly several times. This moves warm oil through the propeller dome assembly and to the supercharger regulators, assures adequate lubrication of the turbo wheel shaft bearings, and clears the balance lines for proper waste gate operation. At the same time the copilot runs the flaps all the way down and back up, checking against the flap indicator. Then the pilot retards throttles to 1000 rpm.

Pilot: "Turbo-superchargers exercised!"

Copilot: "Propellers and flaps exercised!"

## IT IS NOT NECESSARY TO EXERCISE ELECTRONIC SUPERCHARGERS

#### \*4. Copilot: "PROPELLERS?"

Copilot double checks to see that propellers are left in high rpm because governor limit lights also come on when propellers are in low rpm.

Copilot: "Propellers in high rpm!"



### 5. Copilot: "RUN UP ENGINES!"

Run up engines in the following order: 4, 3, 2, 1. Pilot advances No. 4 throttle until the propellers reach 2000 rpm and copilot checks all engine instruments. Copilot checks magnetos at signal from the pilot. Technique: (a) Check tachometer for steady reading on "BOTH." (b) Turn ignition switch to "LEFT MAGNETO" and hold 3 to 5 seconds. Note any drop in rpm (maximum allowable drop is 100 rpm). (c) Switch back to "BOTH" and hold until rpm is steady. (d) Switch to "RIGHT MAGNETO" and check same as right. (e) Switch back to "BOTH" and leave there.

During magneto check pilot should watch engine nacelle for excessive vibration.

**Note:** Where takeoffs are being made frequently, clearing out the engines may be substituted for the full run-up procedure on subsequent checks. If takeoffs are infrequent, make a complete run-up each time. In either case, make the magneto check for **all** subsequent takeoffs.

**Copilot: "Magnetos checked!"**

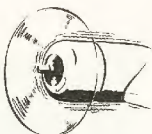

## Double Check

**DON'T INADVERTENTLY LEAVE THE IGNITION SWITCH ON LEFT OR RIGHT MAGNETOS.**

### Run-up Procedure With Electronic Turbo Control

When using the electronic turbo control, set the propeller governors in high rpm, and check the manifold pressure on each engine sepa-

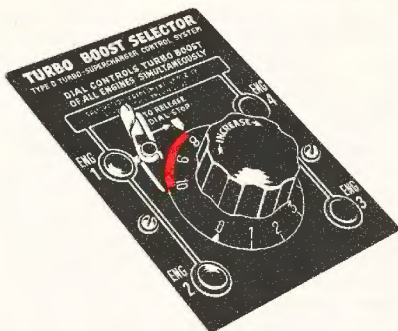

rately by advancing throttle to full open position. Then turn dial of turbo boost selector clockwise to the desired position ("8" with Grade 100 fuel). If the manifold pressure on any engine fails to come up to within 1" of takeoff pressure, with full high rpm, turn dial to zero and check engine rpm and manifold pressure without turbo boost. This will show whether the low manifold pressure is caused by faulty engine operation or by insufficient turbo boost. Also check the voltage with generators on. If batteries are low, leave the generator of the engine you are checking on during run-up to insure proper turbo operation.

After checking an engine, return the dial to zero before retarding the throttle. After you have checked all engines, set the dial to desired position for takeoff ("8" with Grade 100).

**Caution:** When using electronic supercharger control, always be sure generators are on and operating for takeoff.

**Pilot: "NO. 4 RUN-UP COMPLETED!"**

(Repeat the run-up operation for engines 3, 2, and 1.)

### Run-up With Oil Regulated Turbo Control

Pilot advances throttle fully open, holding it there with his right hand while he advances the supercharger control with his left hand until manifold pressure starts to increase. Precaution: This is the most sensitive point in supercharger regulation. Hesitate briefly to allow the turbo surge to balance out and to avoid ini-

## RESTRICTED

tial excessive manifold pressure. As the manifold pressure climbs and stops, move the supercharger control slowly open and you should get a direct, smooth increase to the desired manifold pressure.

When using Grade 91 fuel with the oil regulated turbo control, the spring-loaded stops on the control levers do not allow sufficient travel to give the extra manifold pressure needed in an emergency. (This is in contrast to Grade 100 fuel.) To be on the safe side, use your finger for an additional spacer to provide the necessary travel.

### Note: Carburetor Air Filters

When carburetor air filters are being used to overcome dust conditions, air normally taken in through the air scoop in the engine cowl is blocked off and air is taken through the filter, at the back of the nacelle. Friction and the elimination of ram pressure lowers the pressure of filtered air going to the superchargers. When not using filters, set superchargers 1.5" Hg. below desired manifold pressure to allow for intake ram as speed increases during takeoff. When using the filter, use desired takeoff setting with no allowance for ram.

The turbo wheels have to turn faster to offset the loss of pressure through the filters. Turn the filters off as soon as you are out of the dust area (never leave them on above 12,000 feet) because there is a possibility of exceeding turbo wheel speed limits.

### \*6. Copilot: "LOCK SUPERCHARGERS!"

Pilot sets friction lock so that levers may be readily moved but will not creep back from vibration. Remember that the throttle and supercharger locks are in reality friction brakes and should be treated as such. Friction lock applies to oil regulated turbo control only.

Pilot: "Superchargers set and locked!"

### \*7. Copilot: "GYROS?"

Pilot makes a final check, noting any precession since taxiing from the line, and re-sets for takeoff.

Pilot: "Gyros uncaged and set!"



### \*8. Copilot: "WING FLAPS?"

Copilot runs wing flaps down to 20° position.

Copilot: "Wing flaps 20°!"

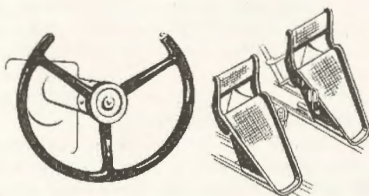

### \*9. Copilot: "FLIGHT CONTROLS?"

To check full travel and freedom of movement, pilot moves controls to full forward and right on the wheel, right rudder; then moves them to full back and left on the wheel, left rudder.

Pilot: "Controls checked for full travel and free movement!"

### \*10. Copilot: "DOORS AND HATCHES?"

Engineer closes doors and hatches.

Engineer: "Doors and hatches closed!"

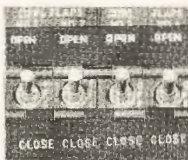

### \*11. Copilot: "COWL FLAPS?"

Copilot closes them to trail position.

Copilot: "Cowl flaps at trail!"

\*ITEMS WITH ASTERISK FOR SUBSEQUENT TAKEOFF.

See that cowl flaps are all closed the same. If open too much, they will cause loss of lift, increased drag, and severe flutter of the tail surfaces. It is better to have cowl flaps completely closed than too far open. Engines may idle at 1000 rpm for a reasonable time with cowl flaps closed and not heat up. Don't take off if a head temperature is less than 150°C or more than 232°C. Desired level is 205°C. Note: Each degree of cowl flap opening produces .8 mph loss of speed.

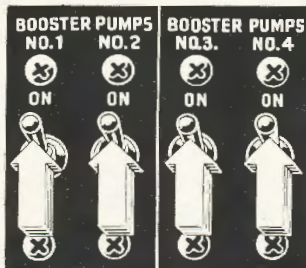

**\*12. Copilot: "BOOSTER PUMPS?"**

Copilot turns all fuel booster pumps on. This builds up a differential of 8 lb. in the rubber lines to the engine to keep them from collapsing. It is also a safety precaution in case of engine pump failure.

**Copilot: "Booster pumps on!"**

**\*13. Copilot: "AUXILIARY HYDRAULIC PUMP AND POWER UNIT?"**

Engineer shuts these off to eliminate a fire hazard on takeoff. The auxiliary hydraulic pump is the only open-brush motor in the bomb bay and the cooling fan tends to draw any gas fumes into the motor.

**Engineer: "Auxiliary hydraulic pump and power unit off!"**

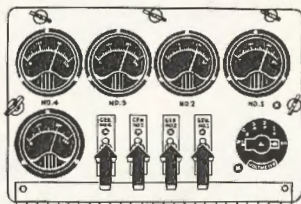

**\*14. Copilot: "GENERATORS?"**

Engineer responds "Standing by" and switches on all 4 generators while takeoff power is being applied. He stands by the panel to turn off any generator indicating excessive load. If this is necessary, he waits until the other generators show signs of sharing the load before returning the off generator to the line, and switches it off again if it fails to equalize.

**Engineer: "Generators on!"**

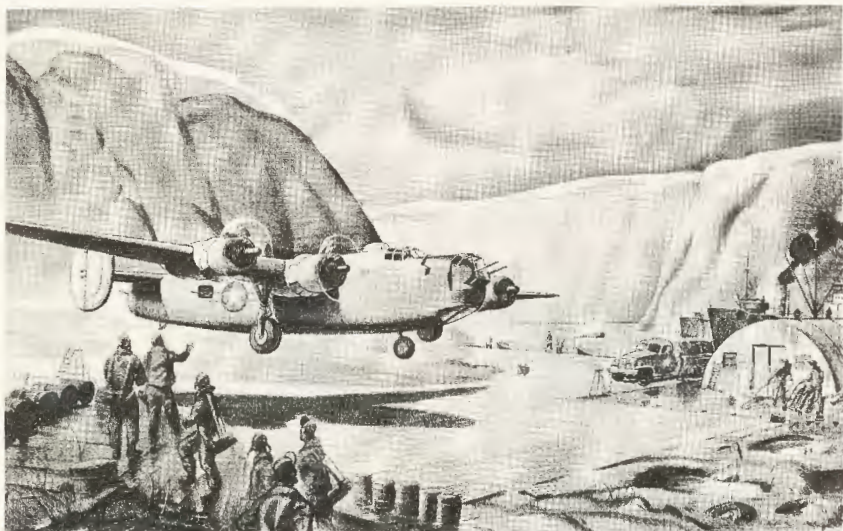

## TAKEOFF

Takeoffs are easy and smooth in the B-24 provided there is plenty of room and you use proper technique. Tricycle gear improves both the takeoff and landing characteristics. Be sure before you leave the line that the runway is long enough (considering altitude, temperature, etc.—see takeoff chart) and be sure there are no obstructions in your line of flight.

### Taxiing Into Position

Get your clearance from the tower to line up on the runway. Take a good look for aircraft and taxi out in a wide sweep using a minimum of runway for straightening the nosewheel. Stop the airplane lined up straight ahead, hold your position with the brakes, and set all throttles at 1000 rpm. Both pilot and copilot should make a final quick check on all instruments.

Then copilot obtains a radio clearance for takeoff and you are ready for the takeoff run.

### The Takeoff Run

1. Release the brakes and slowly but steadily advance all throttles together. Learn to apply power at the speed engines can readily take it. Never jam or stiff-arm the throttles.



2. If you start to move to the left of the middle of the runway lead the throttles on the left, and vice versa. Don't stop the opposite set of throttles, but instead lead all throttles progressively. In this manner you can build up speed rapidly and obtain rudder control quickly. **Don't ever** attempt to control direction on takeoff by the use of brakes.

3. As soon as you have rudder control, use it! Come in with lots of rudder to hold your line down the runway, rather than using excessive and unnecessary build-up of power on one side.

4. Copilot follows throttles through with his left hand, and as soon as they are against the stops he sets the friction lock to prevent throttles from creeping but so they still can be easily moved. **Note:** Pilot's hand should be on the throttles throughout the takeoff except when necessary to trim the plane or signal the copilot. Whenever pilot's hand leaves the throttles, copilot should hold them. Copilot should closely observe all instruments (particularly manifold pressure and rpm). Use full throttle on takeoff. This shortens the run and minimizes wear and tear on tires and gear. Manifold pressure should not exceed 49" for Grade 100 fuel or 42.7" for Grade 91 fuel and propellers should not exceed 2700 rpm. Power reduction necessary to keep within manifold pressure limits should be made with the throttles and not with the turbo regulators.

5. As your speed increases to 70 or 80 mph so that you have elevator control, ease back on the control column just enough to relieve the nose-

wheel of its weight. When full weight is on the nosewheel, the wing is at a negative angle of attack; lifting the weight puts the wing in the desired slightly positive angle.

6. Hold this attitude straight down the runway, and the airplane will fly itself off the ground at 120 to 130 mph, depending on the gross weight. Don't haul it off, however, and be sure the attitude is correct. If you apply too much back pressure, pulling the nose too far up, you establish too great an angle of attack, which creates more lift and puts the plane into the air at a lower airspeed—110 mph, for example. Then, if you lower the nose to pick up airspeed, you decrease the angle of attack and therefore decrease the lift. The airplane cannot accelerate fast enough to compensate for this changed angle, and the result will be that you settle back on the ground. So don't try to make the airplane fly—let it fly itself. Once it does, increase the back pressure just enough to establish a shallow positive climb, and **hold it.**

**Note:** Even if you have to get the airplane into the air at a low airspeed (in a short-field takeoff, for instance), don't lower the nose; hold

#### START YOUR TAKEOFF RUN



#### RELIEVE NOSE WHEEL OF ITS WEIGHT



#### AIRPLANE WILL FLY ITSELF OFF

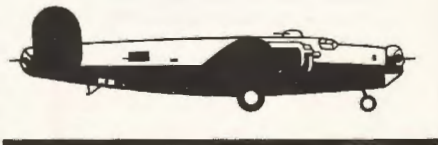

## RESTRICTED

your angle of attack and let the airspeed build up gradually.

7. Don't become over-anxious about building up climbing speed. It takes time for the power of the propeller thrust to overcome the inertia of a heavy airplane. Beware of lowering the nose below level flight to build up airspeed. Always make all changes of attitude gradually, a little at a time. Make frequent small changes rather than large ones. As your airspeed increases, relieve heavy fore or aft control pressure by trimming.

If you set artificial horizon properly before takeoff, with the miniature airplane slightly below the horizon bar, you can hold the proper angle of climb after leaving the runway by keeping the miniature airplane approximately  $\frac{1}{8}$ -inch above the horizon bar. Establish and hold proper attitudes in the B-24 by reference to flight instruments rather than to outside objects. It's an instrument plane.

8. Attain a minimum airspeed of 140 mph and a safe altitude above all objects before your first power reduction.

## AFTER-TAKEOFF CHECK

### Amplified Checklist

1. **Wheels.** Copilot raises gear on signal from the pilot, (usually thumb jerked upward). As soon as the gear handle is in the "UP" position, pilot stops the wheels with smooth, firm application of brakes. This reduces the strain on the

## Important

The copilot reads the after-takeoff checklist when the gear and flaps are up, the first power reduction is completed, and when a safe altitude and an airspeed of 150 mph are reached.

main gear suspension assemblies caused by the gyroscopic action of rapidly rotating wheels. Rough application of brakes puts undue strain on the gear fittings and may rupture an expander tube.

**Caution:** There is no hurry about raising the wheels. Be sure you have plenty of airspeed and altitude before you start them up.

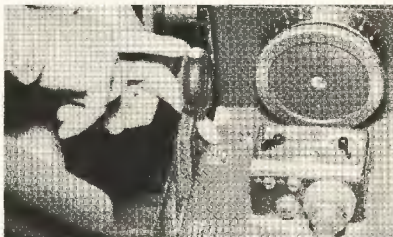

### Press the Button

When the copilot raises the gear, he should be sure to press down the safety button located on top of the gear handle to unlock it. Forcing the handle against the lock will injure the locking pin.

If the solenoid latch does not release, you can push the releasing pin in with a screwdriver and then raise the gear handle to bring the wheels up. The latch is located behind the pilot's instrument panel just forward of the pedestal. **Don't try this on the ground because you will retract the gear and the airplane will crash down on its belly.**

2. **Superchargers.** When the airplane attains safe airspeed (140 mph) and altitude, the pilot makes the first power reduction with superchargers and sets them for normal climb (not to exceed 46" for Grade 100 or 38" for Grade 91 fuels).

**Power Reduction With Electronic Turbo Control:** Turn the turbo control dial back toward zero until you reach the desired manifold pressure.

3. **Throttles.** If manifold pressure remains higher than desired for climb after superchargers are all the way off, then retard the throttle to obtain climbing manifold pressure.

4. **Propellers.** Copilot reduces rpm to 2550 when requested by the pilot.

5. **Wing Flaps.** Copilot raises them when directed by the pilot. Don't raise the flaps before you have altitude of 500 feet and an airspeed of 140 mph. Remember that changes in flaps change the lift effect of the wing. As you raise the flaps, raise the nose of the airplane to correct for change in attitude. Use enough back pressure to maintain altitude and the airplane will rapidly accelerate to 150 mph. Don't lower the nose to gain this speed because this will result in unnecessary loss of altitude. Add nose-up elevator trim to help maintain your altitude.

In heavily loaded aircraft, it is advisable to raise the flaps from 20° to full up in two or three stages.

**Warning:** Don't be in a hurry. Get a safe air-

speed and a safe altitude before you raise the flaps. But don't let airspeed exceed 155 mph with flaps down.

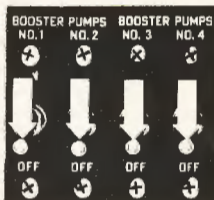

6. **Booster Pumps.** Copilot switches them off one at a time above 1000 feet and notes any drop in pressure.

7. **Cowl Flaps.** Will normally be at trail for the climb, checked and set by the copilot.



## RUNNING TAKEOFF

### Procedure

1. Bring the airplane down to a normal 2-point, nose-high landing.

2. When speed has decreased to 80 mph (about  $\frac{1}{2}$  distance of a normal landing roll), gently lower the nose to a normal 3-point position.

3. Be sure you have ample runway left in which to re-accelerate and take off.

## RESTRICTED

4. At command of the pilot, the copilot raises the flaps from 40° to 20° and trims for normal takeoff as the pilot smoothly applies normal takeoff power. Remember that the airplane is already moving fast, and don't advance throttles too rapidly.

5. Speed permits the pilot to maintain directional control entirely with rudder. It isn't necessary to apply power unevenly or to use brakes.

6. Lift the weight off the nosewheel as soon as throttles are full forward.

7. Avoid a tendency to pull the airplane off the ground at low speed and at a high angle of attack. Build up adequate airspeed and break contact as in a normal takeoff.

8. In other respects, proceed exactly as in a normal takeoff.

**Caution:** On running takeoffs watch cylinder-head temperatures and open cowl flaps to trail if necessary.

**Warning:** Don't hit the gear handle when you mean to raise the flaps. Remember you have full flaps down as you roll along the runway and are bringing flaps to 20° to re-establish normal takeoff settings.

Copilots have been known to reach for the flap handle and unintentionally hit the gear handle from force of habit while wheels are still on the ground. Normally when the weight of the airplane is on the gear, gear handle cannot be moved to the up position. In a running takeoff, however, enough weight may be off the gear while wheels are still on the concrete to allow oleo to extend far enough to close safety micro switch in the left main gear and allow the gear to unlatch and collapse.

Don't let flaps come all the way up. The Davis wing needs 20° of flaps for additional lift.

Don't raise the gear until you are safely clear of the ground. This is deceiving on running takeoffs.

---

## CROSSWIND TAKEOFF

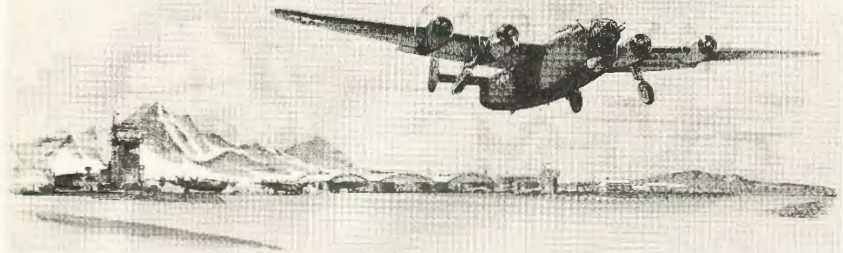

You will experience no difficulty with a B-24 in crosswind takeoffs. Proper leading of throttles and use of rudder pressure will hold the airplane straight down the runway.

Inherent directional stability of the tricycle landing gear tends to keep the airplane straight on its roll as long as the nosewheel is on the ground. There is no tendency to weathercock.

Be sure, especially on bumpy runways, to

build up ample flying speed before leaving the ground. Otherwise the airplane may settle back down as it starts to drift and place severe strain on the landing gear.

As soon as you are clear of the ground, hold the wings level and establish a crab with rudder to continue down the runway path. Don't drop a wing, because this reduces your lift. Continue as in a normal takeoff.





## HIGH-PERFORMANCE TAKEOFFS

Where it is necessary to take off in as short a distance as possible, execute a high-performance takeoff. This, on an average, reduces your ground run approximately 200 feet and reduces the total distance necessary to clear a 50-foot obstacle by approximately 600 feet.

Be sure you have proper authority and are going to succeed before you attempt a high-performance takeoff. Several variables must be considered: Pressure altitude, free air temperature, model and weight of the airplane, wind, and type of runway surface. Don't take a chance. Taking all these variables into consideration, precalculate the answers to 3 questions before you attempt a takeoff:

1. What ground run will be required?
2. What will the takeoff airspeed be?

3. What distance will be required to clear a 50-foot obstacle?

Use the high-performance takeoff chart in this manual (if suitable) or in the technical order for the model of airplane you are flying to answer these questions. Calculate carefully and double-check your answers. When you are satisfied that the high-performance takeoff can be safely made, use the following procedure.

### Procedure (Based on Grade 100 fuel)

1. Complete the before-takeoff check. Run up each engine separately to 2700 rpm and 47" manifold pressure. (This setting allows for a 1½" increase in manifold pressure due to ram.)
2. Set wing flaps at 20° as for a normal takeoff. Set cowl flaps at 5° to reduce drag.

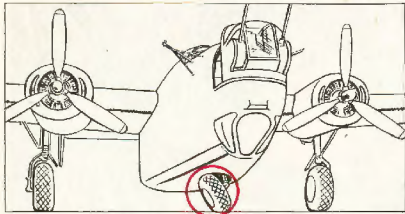

**EXAMPLE OF WHAT MAY OCCUR IF NOSE WHEEL IS NOT LINED UP WITH RUNWAY**

3. Line up with the runway and make a positive check that the nosewheel is straight.
4. Hold the brakes and advance the throttles smoothly and evenly to establish 35" of manifold pressure. Then release the brakes.
5. As rapidly as possible, advance the throttles to full open position.
6. Make your takeoff run in a normal manner until you reach your precalculated takeoff speed! Then use sufficient back pressure to break contact and gradually establish the desired angle of climb. Some margin of safety is necessarily sacrificed by this procedure.

#### Another Good Method

Here is another good method if you have room and can continue your roll from the taxi strip onto the end of the runway. Execute in the same manner as the first procedure, except that you roll directly from the taxi strip into your takeoff run without stopping.

Avoid using brakes in the turn. Lead with throttles on the outside of the turn. When you have sufficient momentum to carry you through the turn, retard that set of throttles, and as the nose approaches the center line of the runway, advance throttles on the inside of the turn sufficiently to check the turning action. Immediately follow up with the other set and advance all throttles progressively as rapidly as possible to the desired takeoff manifold pressure. This procedure gives you the advantage of having the mass weight of the airplane in motion at the extreme end of the runway, permitting you to take full advantage of every foot of runway available.

**Caution:** You gain nothing by having too much speed in executing the turn. You are likely to roll a tire or damage the gear. The main thing is to have the weight in motion at the extreme end of the runway.



## THE CLIMB

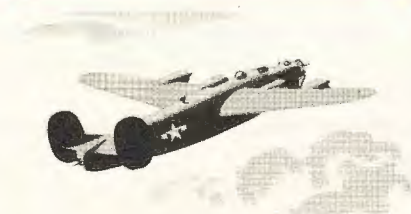

You will judge the proper angle of climb by obstacles to be cleared, airspeed and the flight indicator. The best average airspeed for the climb after completing the after-takeoff check (wheels up, flaps up, etc.) is 150 to 160 mph.

Pilot should relieve control pressures by proper trimming and copilot should synchronize propellers as soon as convenient after wheels and flaps are up. Both pilot and copilot should keep a roving eye on all instruments to see that power, temperatures and pressures all stay within limits.

### **Auto-rich for All Climbs**

Throughout all climbs mixture controls should be in "AUTO-RICH," for at high power it is

## RESTRICTED

necessary for the proportion of fuel to air to be relatively high to suppress detonation and assist in cooling.

### Effects of Increasing Altitude

As altitude increases, these things are occurring: The engines are generating more and more heat the longer they work at climbing power, tending to increase cylinder-head and oil temperatures; normally the indicated air temperature is gradually falling; atmospheric pressure is gradually decreasing; it becomes more difficult to obtain sufficient oxygen from the atmosphere. It is important to consider the effects of each of these conditions on your airplane and crew.

### Engine Heat

1. **Cylinder-head Temperatures:** Adjust cowl flaps to control head temperatures. Normally, head temperatures will run about 232°C but should never exceed the maximum of 260°C nor fall below 150°C, the operating limits of the

engine during the climb.

2. **Use of Cowl Flaps:** Keep in mind that the position of cowl flaps seriously affects your rate of climb because of added drag and disturbance of the airflow—so much so that your airplane may not climb above 23,000 feet with cowl flaps only slightly open. Also, cowl flaps open from 10° to 20° will sometimes cause severe tail buffeting. If necessary to use more than 10° to maintain head temperatures within limits, try opening them farther until the tail buffeting stops.

**Note:** On late series B-24 aircraft, differential cowl flap settings restrict the upper cowl flap opening to 12¾°.

3. **Oil Temperatures:** Oil temperatures can be reduced more quickly by decreasing engine rpm along with throttles than by reducing the throttles alone.

4. **Other Methods:** Another good way to reduce both cylinder-head and oil temperatures is to shallow your climb so that your IAS is 5 to 10 mph greater than normal climbing airspeed.

## CLIMBING POWER SETTINGS

### GRADE 100 FUEL—SPECIFICATION ANF-28

Operation	Setting	Mixture	RPM	MP	Time Limit	BMEP	HP
Climb	Desired	Auto-rich	2550	41	Continuous	167	990
Climb	Max.	Auto-rich	2550	46	Continuous*	186	1100

### GRADE 91 FUEL—SPECIFICATION ANF-26

Operation	Setting	Mixture	RPM	MP	Time Limit	BMEP	HP
Climb	Desired	Auto-rich	2550	35	Continuous	147	870
Climb	Max.	Auto-rich	2550	38	1 Hr.	160	950

\*Cyl. head temp. not to exceed 232° C. For temperatures of 232° to 260° C, time limit is 1 hour.

The above are normal limits. Variations within limits will be governed by the type of operation for a particular organization.

This will not cause much loss in your rate of climb.

In case of extreme cylinder-head and oil temperatures, use **emergency "FULL RICH"** mixture (with Bendix-Stromberg carburetors). This will dissipate the heat very rapidly but will also cause a loss of power and excessive gas consumption. Use only long enough to reduce temperatures. Excessive temperatures are sometimes caused by failure of the automatic feature of "AUTO-RICH." "FULL RICH" corrects this because it gives a fixed mixture.

### Decreasing Air Temperature

1. **Carburetor Air Temperature:** On an extended climb when the relative humidity is high, check regularly to be sure your carburetor air temperature is either above or below the icing range ( $-5^{\circ}\text{C}$  to  $+15^{\circ}\text{C}$ ). You can get carburetor ice with little or no warning.

2. **Intercooler Shutters:** Hot compressed air is coming to your carburetor from the supercharger through the intercoolers. Intercooler shutters are kept in the **open** position to cool this compressed air. It is practically never necessary to close intercooler shutters except in very severe carburetor icing conditions. (See Carburetor Icing.) If you do close them, keep a close watch to see that both carburetor air temperatures and cylinder-head temperatures don't suddenly rise beyond limits. Intercooler shutters should always be used with utmost caution to avoid overheating.

3. **Heater:** Remember that there are crew members all over the airplane who may be getting cold. Ask them if they want some heat. The longer you can keep them warm the more effective they will be with their headwork, their bombs, and their guns. Crew comfort is important to crew efficiency.



### Decreasing Atmospheric Pressure

1. **Airspeed Indicator:** Decreasing atmospheric pressure causes your airspeed indicator to show an airspeed lower than your true one.

2. **Manifold Pressure:** The density and pressure of the outside air is decreasing as altitude increases. At sea level normal atmospheric pressure will, on some engines, be sufficient to maintain the desired manifold pressure. As altitude increases, and full throttle fails to give sufficient manifold pressure, you add boost with the turbo-superchargers.

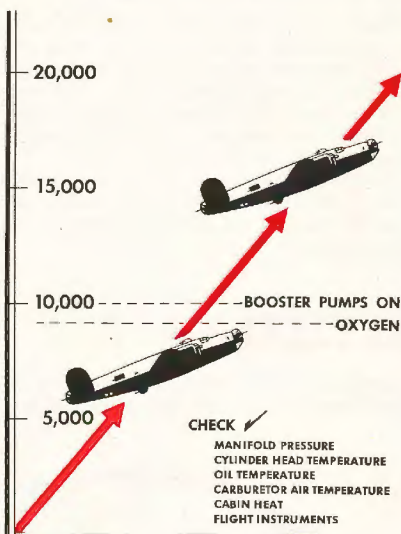

**Note:** With oil-type turbo regulator, when climbing at a given throttle setting, rpm, and turbo regulator setting, the manifold pressure will increase slightly as altitude increases because the atmosphere has less back-pressure effect in relation to the constant exhaust pressure. This results in a steady increase in turbo wheel speed and thus increased manifold pressure.

3. **Booster Pumps On at 10,000 Feet:** As you climb and the atmospheric pressure decreases,

## RESTRICTED

there is more and more tendency for a vapor lock to form and for suction from your engine-driven fuel pump to collapse the rubber fuel lines. Booster pumps put 8 lb. additional pressure in the lines to help support them. Turn the booster pumps on at 10,000 feet and keep them on until you descend below that altitude.

4. **Crew:** As altitude increases, your crew is becoming less efficient. Their ears tend to bother them. Head congestion may cause severe pain. They are getting insufficient oxygen. Always use oxygen above 10,000 feet.

### The Importance of Smooth Flying

Smooth, steady flying, proper trim, and minimum horsing of the airplane become more and more important to maximum performance as altitude increases. Steady, expert flying will reduce your fuel consumption, eliminate hazards, increase your rate of climb, and reduce wear and tear on your engines.

Remember that the only way you can maintain a constant attitude, steady climb and smooth flying in the B-24 is by reference to instruments.

## LEVELING OFF

Always level off for cruising **from the top** in both speed and altitude. The purpose of this

is to let the airplane build up full momentum for cruising. If you go directly from a climb to level flight with a B-24, and reduce power, it will mush along at a high angle of attack and in a high drag attitude while trying to gain speed. It will fly sluggishly and inefficiently. The heavier your load, the more important it is to level off properly.

### Leveling-off Procedure

1. Continue your climb 300 to 500 feet above the desired cruising altitude.
2. Level off, drop the nose slightly to get on the step and pick up speed.
3. Reduce power to cruising setting and gradually descend to your cruising altitude.
4. Synchronize propellers and trim the airplane.

### Cool Off the Engines

Remember that throughout the climb the engines have been generating heat. Give them a chance to cool down somewhat below desired cruising temperatures before you change to "AUTO-LEAN" mixture settings. This allows cylinders, blower and rear sections to dissipate heat. A well-cooled engine is less likely to detonate when the mixture is leaned than a hot engine.

To aid cooling, don't close the cowl flaps immediately upon completing the climb. Instead, close them progressively as airspeed builds up.

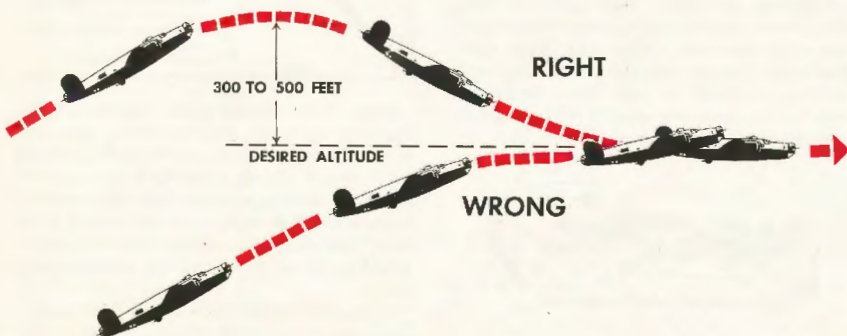

## HOW TO SYNCHRONIZE PROPELLERS

The copilot brings propellers to the desired tachometer setting with the propeller governor control switches. Although rpm readings are identical for all 4 engines, propellers may not be perfectly synchronized because of slight variations in tachometers. To synchronize, copilot should follow this procedure:

1. **No. 1 and No. 2 Propellers:** Leave No. 2 (inboard) as it is. Note the rotating shadow around the top half of No. 1 propeller. If the shadow is rotating away from you, the propeller is too slow and should be increased; if the shadow is rotating toward you, the propeller is too fast and should be decreased.

2. **No. 3 and No. 4 Propellers:** Leave No. 3 (inboard) as it is. Note the rotating shadow around the top half of No. 4 propeller. Here the procedure is reversed. If the shadow is rotating away from you, the propeller is too fast and should be decreased; if the shadow is rotating toward you, the propeller is too slow and should be increased.

**Note:** An easy way to keep this straight is by remembering that all propellers in the B-24 rotate to the right. Thus, from the cockpit, No. 1 propeller is turning toward you and No. 4 going away from you. If the shadow is rotating with the propeller, then the propeller is too fast; if the shadow is rotating backward (against the propeller rotations), then the propeller is too slow.

3. Increase or decrease rpm by a split-second flick of the toggle switch and at the same time check the effect on the shadow. The shadow will disappear when propellers are synchronized.

4. If the shadows have disappeared and the engines still sound unsynchronized (engine beat or pulsation), then No. 1 and No. 2 are not synchronized with No. 3 and No. 4.

5. To synchronize the left pair of engines with the right pair, check the tachometers to see if one pair is indicating less than the de-

sired rpm. If so, flick both switches for that pair forward at the same time and back to neutral quickly. Repeat until you eliminate the beat and get a steady drone. If the beat gets worse, decrease rpm instead of increasing.

6. Now all 4 propellers should be synchronized. However, the propeller governors for the propellers that were changed as a pair may respond unevenly. If so, re-synchronize them.

**Note:** The difference in needle travel on the tachometers will tell you which propeller governors are fast and which are slow. With practice you will be able to lead with the toggle switches for slow-acting governors to bring all propellers to the desired rpm at the same time.

### At Night

Use your landing lights or a flashlight to see which way the shadows are turning. With experience it is possible to synchronize propellers by sound

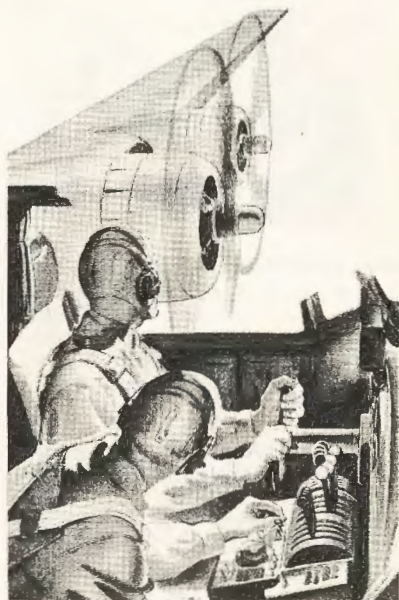

## TRIMMING

Trimming the B-24 is a routine procedure but tremendously important to the easy and proper operation of the airplane. Brawny, 200-lb. pilots have exhausted themselves in an hour's flying because they failed to trim properly and frequently enough. Poor trim cuts down the airspeed, increases fuel consumption, lowers the speed and ceiling of a climb, and decreases the efficiency of the airplane and the pilot. Formation flying is a nightmare if the airplane is poorly trimmed.

Trim the B-24 by instruments—not by visual reference to outside objects. But keep a sharp lookout for other traffic at all times.

Following is the easy, sure way to properly trim the airplane for straight and level flight.



### Balance the Power

See that you are using balanced power. Propellers should all be synchronized and you should have equal manifold pressure on all engines. **This is important!** Manifold pressures must be equalized to a hair to give balanced power.

### Elevators

1. Check the altimeter with the flight indicator and reset the latter if necessary for level flight.

2. Hold the airplane level with reference to the flight indicator and adjust elevator trim to

relieve any fore and aft pressure required to hold the nose level.

### Rudders

1. Hold the wings level with the ailerons by reference to the flight indicator and remove all rudder pressure.

2. Watch the directional gyro to see if the airplane is turning. Gradually correct with rudder trim until the directional gyro holds a steady course straight ahead.

### Ailerons

1. Level the wings, hold a gyro heading with rudder, and release the wheel.

2. If the flight indicator shows a wing is dropping, correct with aileron trim.

### Double-check

Finally, check the directional gyro, flight indicator and needle and ball with hands and feet off controls to make sure of proper trim. Once the airplane is properly trimmed, small adjustments will usually keep it there. Trimming should become automatic.

### When to Trim

Trim at the first sign of excessive control pressure. You will want to trim for climbs, descent, gear down or up, flaps down or up, when the crew changes positions, as the fuel is used up, when your bombs are dropped, in case of engine failure, etc.

### Relationship of Load and Trim

If the airplane is perfectly loaded, it is possible to fly it hands off with one or two degrees of tab setting. On long flights tab settings become extremely important. A loss of 3 to 4 mph in airspeed can result from 1° of tabs on one control surface. Thus, if your ship is improperly loaded and you have to use a lot of trim, it is worth while to shift cargo to establish better balance.

Don't kid yourself by holding pressures manually instead of using trim.



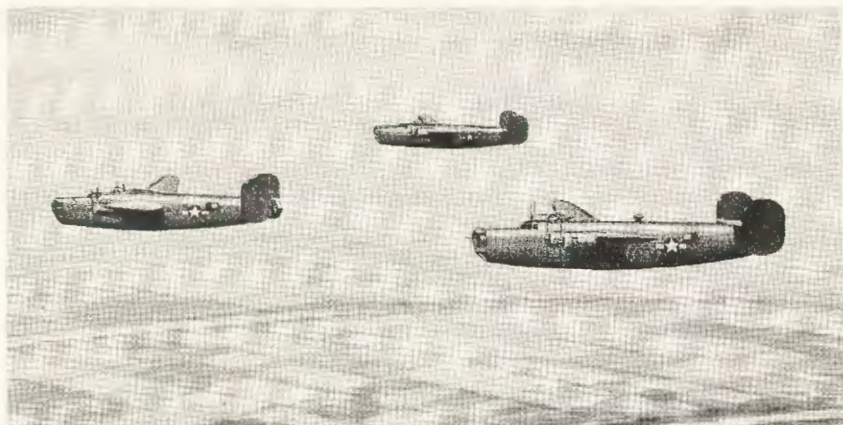

## CRUISING

As soon as you have leveled off, synchronized propellers, trimmed the airplane, and let the engines cool down, check all instruments preparatory to going into auto-lean.

### Normal Automatic Lean Pressures and Temperatures

1. Cylinder Temperature: 232° C maximum.  
205° C desired.
2. Oil Temperatures: 100° C maximum.  
75° C desired.
3. Oil Pressures: 65 to 100 lb. sq. in.
4. Fuel Pressures: 16 to 18 lb. sq. in.

## CRUISING POWER SETTINGS

### GRADE 91 FUEL—SPECIFICATION ANF-26

Operation	Setting	Mixtures	RPM	MP	Time Limit	BMEP	HP
Cruise	Normal	Auto-lean	1650-2100	30	Continuous	—	—
Cruise	Local	Auto-lean	2000	30	Continuous	131	610

### GRADE 100 FUEL—SPECIFICATION ANF-28

Operation	Setting	Mixtures	RPM	MP	Time Limit	BMEP	HP
Cruise	Maximum	Auto-rich	2325	35	Continuous	150	820
Cruise	Maximum	Auto-lean	2200	32	Continuous	140	715
Cruise	Desired	Auto-lean	2000	30	Continuous	131	610
Cruise	Maximum Range: See Cruise Control Charts.						

## RESTRICTED

### Automatic Lean

If instrument readings are satisfactory, and power settings permit "AUTO-LEAN" operation, copilot (at the pilot's direction) moves the mixture controls one at a time to "AUTO-LEAN." Pilot and copilot note the effect of this on temperatures and pressures.

Carburetor air temperature should stay below 35°C. Excessive heat may cause detonation. If an engine gets hot in "AUTO-LEAN" (a less cooling mixture), go to "AUTO-RICH" long enough to cool it down. If it stays hot in "AUTO-LEAN," the automatic feature may not be operating properly and you may have to use "AUTO-RICH" for that engine.

### Superchargers

**Low altitude:** If cruising at low altitude you may have sufficient manifold pressure with superchargers completely off. (Watch for icing, however. If there is danger of icing, close intercoolers and operate as close to full throttle as possible. See Carburetor Icing.)

Above 20,000 feet: Superchargers won't function properly at less than 1800 rpm above 20,000 feet because in less dense air there is insufficient exhaust gas to operate the turbo wheel properly. Don't suspect turbo regulator trouble until you have checked rpm.

### Cowl Flaps

Regulate cylinder-head temperatures with cowl flaps. The closed position reduces drag and increases speed, but also increases engine temperatures.

### Directional Gyro

Check and correct for precessing at least every 15 minutes or as necessary.

### NOTE

Although pilot and copilot will be checking instruments regularly, it is a good idea to call for a complete check and report by the copilot at stated intervals.

### Flying the Airplane

Take pride in your ability to fly the airplane perfectly. You can't expect your copilot or

your crew to develop keen interest in the technique of their jobs unless you set an outstanding example.

**Trimming:** Keep your airplane perfectly trimmed throughout the flight. This will save wear and tear on both yourself and your airplane.

**Heading:** Hold your heading or your navigator will give up in disgust. If you are going to change headings or dive or climb, warn your navigator in advance exactly what to expect.

**Altitude:** Hold your altitude. Don't be satisfied with 200 feet higher or lower.

**Airspeed:** As time passes and your load lightens, your airplane will tend to gain airspeed. Maintain your predetermined IAS by reducing power every 1 to 3 hours. This is a good rule of thumb for efficient cruising.

**Fly the airplane as if you expected to use it in a combat mission tomorrow.**

### Flight Performance Record

It is the copilot's duty, with the assistance of the engineer, to keep a flight performance record of every mission. Entries should be made every 30 minutes. Properly kept this form will:

1. Warn you of excessive gas consumption.
2. Give a running picture of the performance of engines.
3. Provide a check on how efficiently you are flying the airplane.

### Engineer's Hourly Visual Check

Require the engineer to make a visual check once an hour of turbo, cowl flaps, nacelles, fuel cell areas, etc. Many items will have to be checked from the rear of the airplane. When on oxygen, check can be conducted with the use of a walk-around bottle.

### Oxygen

When on oxygen, require the copilot to check crew stations at least once every 15 minutes by interphone to ascertain that crew members are all right and have an adequate supply of oxygen on hand.

## GENERAL FLIGHT CHARACTERISTICS

The flight characteristics of the B-24 are outstanding without exception if the airplane is properly loaded. It has no abnormal or bad characteristics. The tremendous power plant will carry huge loads great distances at high speeds with ease.

### Inherent Directional Stability

The airplane has inherent directional stability which may be maintained for long periods by slight adjustments in trim. However, controls are normally heavy, as they should be in a heavy airplane, and the pilot who fails to maintain proper trim is in for an exhausting workout. Properly trimmed, the airplane will fly the desired heading true as an arrow with comfortable control pressures.

### Longitudinal Stability

Longitudinal stability is excellent over a wide range of center of gravity locations. Under normal loadings the airplane will return to normal flight when released from a stall or other abnormal positions. However, when fully loaded, the airplane increases its weight by  $\frac{1}{2}$  to  $\frac{3}{4}$ . If the center of gravity moves too far forward or too far aft, it is easily possible to develop limit load factors. Exercise care in using controls smoothly and gradually when operating near these limits, especially when the center of gravity is in extreme aft positions, because it is easy to develop excessive strain on the tail assembly with sudden heavy elevator pressure.

### Characteristics in Rough Air

The intelligent pilot will avoid violent turbulence because the forces of some storms are incalculable in their intensity. There is nothing critical in ordinary rough-air operation with the Liberator. It will maintain stable flight. It is a waste of effort to fight every slight deviation from level flight. Use pressures to maintain generally level flight and the airplane

will hold its own. Inherent stability will tend to return the airplane to level flight. In a heavy airplane like the B-24, this action is comparatively slow, so give the airplane time to settle down.

In extremely turbulent air slow down to 150 mph. For additional drag and to avoid too great a decrease in power, extend the landing gear but bear in mind that this will have a serious effect on your rate of fuel consumption.

### Don't Fly Contact

The B-24 is strictly an instrument airplane. You must fly by reference to instruments by day and by night, fair weather or foul, if you expect to get the most out of your airplane. The only reason they put windows in the airplane is to permit you to see other aircraft and mountains — so don't fly contact! Remember, however, that it is easy to control the attitude of the airplane by reference to instruments and still keep a sharp lookout. Don't let the instrument panel hypnotize you. Even when the sky seems empty, be heads-up for traffic. Remember what you learned in flying school about the swivel head and the rubber neck. You still need them. Keep crew members on the alert as lookouts, too, as an additional safeguard while you work at the double job of flying by instruments and watching the air around you.

## FLIGHT INSTRUCTIONS

At no time will the following maneuvers be attempted:

LOOP  
ROLL SPIN  
INVERTED FLIGHT  
IMMELMANN  
VERTICAL BANK

## RESTRICTED

### *Always*

- Always follow all items on checklist.
- Always check fuel before takeoff and regularly during flight.
- Always check nosewheel accumulator—if provided.
- Always open intercoolers for starting.
- Always use battery cart when available.
- Always check generator switches "OFF" when starting.
- Always use "AUTO-RICH" except when cruising.
- Always check de-icers "OFF" before takeoff or landing.
- Always use outboard engines for steering when taxiing.
- Always turn "OFF" auxiliary hydraulic pump before takeoff.
- Always check gear latches engaged before landing.
- Always check the automatic pilot "OFF" before takeoff or landing.

### *Never*

- Never execute prohibited maneuvers.
- Never exceed airspeed restrictions.
- Never start engines before pulling props through.
- Never start with low batteries.
- Never start with auxiliary power unit alone.
- Never start with superchargers "ON."
- Never use starter for direct starting. Inertia flywheel must be energized before meshing.
- Never attempt to use intermediate positions on mixture control.
- Never turn on ground too sharply. It will damage landing gear and tires.
- Never attempt to take off with props in low rpm.
- Never transfer fuel with radio "ON."
- Never apply brakes with nosewheel off ground
- Never land with brakes locked.

## AIR SPEED LIMITATIONS

Limiting Factor	Maximum
	Indicated Airspeed
40° Flaps .....	155 mph
10° Flaps .....	180 mph
Lowering Landing Gear.....	155 mph
41,000 lb. Gross Weight.....	355 mph
56,000 lb. Gross Weight.....	275 mph

**Automatic Pilot:** Do not operate the automatic pilot when flying at less than an indicated airspeed of 155 mph or when flying in extremely turbulent air.

**Extremely Turbulent Air:** Slow down to IAS of 150 mph.

**Maximum Gross Weight of 56,000 lbs.:** Do not attempt other than normal flight. Permissible flight factor—2.67; permissible landing factor—2.25.

**Emergency Maximum Gross Weight of 64,000 lb.:** Do not attempt other than normal flight. Permissible flight factor—2.3; permissible landing factor—2.0. Operate only from smooth fields and do not exceed cruising speeds until load has been expended to 56,000 lb.

## STALLS

The B-24 has no unusual stall characteristics. It has sufficient reserves of power; there is no excuse for getting into a stalled condition if the airplane is operated normally.

### Various Factors Affecting Stalling Speeds

Wheels down will increase the stalling speed of the airplane from 3 to 5 mph. The operation of de-icer boots will have a serious effect on the stalling speed. The degree of cowl flap opening will reduce airspeed and affect stalling speeds accordingly.

A feathered propeller is much less of a drag on the airplane than a windmilling propeller. An engine operating at 11" manifold pressure is the equivalent of a feathered propeller.

**COMPARISON OF STALLING SPEEDS**

	Gross Weight Lbs.	Wing Flaps and L.G. Retracted IAS	Wing Flaps 40° L.G. Extended IAS
<b>NO POWER</b>	45,000	110	91
	56,000	123	101
	64,000	132	109
<b>40% POWER</b>	45,000	103	71
	56,000	114	80
	64,000	123	85

**Caution:** All stalling speeds given in this manual have been test flown but speeds will vary slightly from airplane to airplane, of the same weight and series. Speeds given serve as a basic guide only.

**Warning of Stalls:** Usually there is clear warning of an approaching stall. Controls will loosen somewhat and airspeed will be falling off. You will observe a shuddering of the tail and a slight pitching action.

**The Stall:** In the approach to a stall (the usual practice maneuver) the nose will have an increasing tendency to drop. In a complete stall, the airplane will tend to fall off to either side without any inherent tendency to spin.

**Recovery From Stalls:** The stall recovery in the B-24 is like that in almost any other airplane for the most part:

1. Lower the nose to regain flying speed. Because of its aerodynamically clean design, the B-24 will lose a great deal of altitude and pick up speed rapidly.

2. If the stall occurs with decreased power, don't increase power until you have lowered the nose. The purpose is to establish airspeed and prevent rolling action caused by torque.

3. If a wing drops and airplane is turning, correct with rudder. **Don't use ailerons.** Ailerons increase the drag, aggravate the stall and

prolong recovery. You can stop the turn and level the wings with rudder alone.

4. As your nose-low attitude builds up airspeed, blend in power gradually.

5. Don't attempt to raise the nose too rapidly before you regain speed or it is possible to cause a secondary stall more violent than the original one.

6. Properly executed, you will blend in power and raise the nose to level flight so that as you level off you will have established cruising airspeed and normal power settings.

**WARNING CONCERNING  
APPLICATION OF POWER**

Never attempt recovery from a stalled condition by immediate application of power. Those wings are a platform with thousands of horsepower waiting to be lashed into action. When you are in a stalled condition, the platform loses its stability and, if you jam on power, torque may violently roll the airplane to the left. Always lower the nose, straighten with rudder, and blend in power with your gain in airspeed.

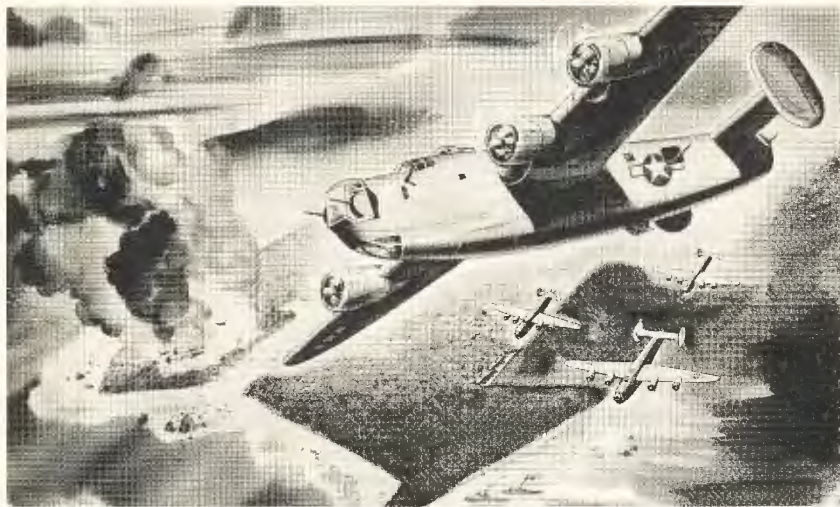

## URNS

Turns in the B-24 should be made by reference to the flight indicator, the directional gyro, needle and ball, altimeter and airspeed indicator. One-needle-width turns are normal and will vary in degrees of bank from approximately  $20^\circ$  for 150 miles an hour up to  $25^\circ$  for 200 miles an hour. Except in emergency, it is recommended that banks not exceed  $45^\circ$  because the load factor at  $60^\circ$  is 2 G's or twice that of level flight. In turbulent air a  $60^\circ$  bank might impose loads far in excess of 2 G's. Steeper banks very rapidly increase this load factor to an unsafe degree. In moderately loaded airplanes banks up to  $60^\circ$  can be made easily and safely, but with heavy loads aboard safety is sacrificed as banks are steepened.

Since rough or turbulent air constantly changes load factors, it is wise to limit banks

to one-needle-width turns in rough air and to reduce airspeed to 150 mph.

### How to Enter the Turn

Drop a wing with aileron pressure to enter a turn, coordinating necessary rudder and back pressure on the elevators. Only slight rudder is necessary. Control resistance is heavy and the response of the airplane is slow and gradual. Don't stop short of the desired degree of bank and then expect the wing to keep dropping. Bring it all the way down to the desired degree of bank and then stop it. It will be necessary to hold aileron against the bank to keep it from getting steeper. The amount of aileron will vary with the degree of bank.

### Difference in Turns

In a left turn, torque gives the B-24 a slight tendency to lose altitude, so it is necessary to come in early with back pressure to keep the nose from dropping.

In a right turn, torque causes the airplane to want to climb as you start the turn and the airplane holds its altitude slightly longer, so you delay the use of back pressure accordingly.

#### Rolling Out of the Turn

Keep in mind that you are controlling a large mass of weight on a platform that stretches 55 feet out on each side of you. Establishing a turn and rolling out of it take time. To roll out of a 30° bank on a heading, give your roll-out about 15° of lead. Your roll-out will require smooth, solid application of controls, and as in rolling in, it is necessary to roll all the way out to level flight. Don't relax ailerons until you are level by the flight indicator. Proportion of aileron used is much greater than rudder on both entry and recovery compared with other planes. The common tendency of most pilots on the B-24

is to overcontrol with rudder, throwing ball off center.

Make allowances for torque again in the roll-out. You'll have to use more back pressure in a left turn than in a right turn and will need some forward pressure in the roll-out from a right turn to keep from climbing as you near level flight.

#### Stalls in Turns

There is little danger of stalls in turns if you maintain required airspeeds and do not force the turn. But remember that there are many factors affecting stalling speeds, including power settings, weight, wing flap setting, degree of bank, cowl flap setting, use of de-icers, and landing gear position.

The table of stalling speeds in turns gives you an idea of how variable this factor is and how rapidly stalling speeds increase in turns.

## HOW STALLING SPEEDS INCREASE IN TURNS

Gross Weight	Wing Flap Position	30° Bank IAS	60° Bank IAS
43,000 lb.	0°	115	152
	20°	101	133
	40°	86	113
50,000 lb.	0°	124	163
	20°	109	143
	40°	93	122
56,000 lb.	0°	131	173
	20°	115	152
	40°	98	129

NOTE: Excessive back pressure in any of these turns will cause the stalling speeds to be much higher.

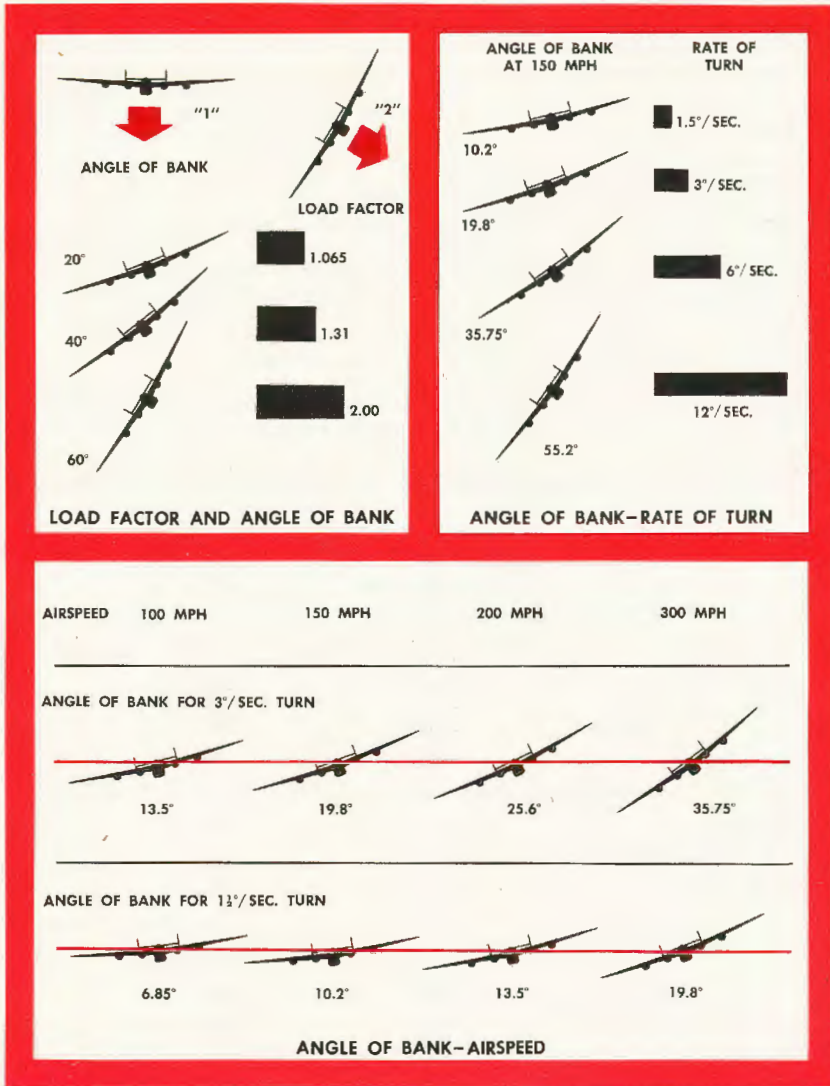



# DIVES

## Dividing Speed Limits

41,000 lb. ....	355 IAS
47,174 lb. ....	325 IAS
56,000 lb. ....	275 IAS

Never violently dive the B-24. Under normal flying conditions you will never have occasion to exceed 250 mph in a dive. The airplane can take it up to certain limits but these limits vary greatly with the amount and position of loading. Air loads build up rapidly in a large airplane so avoid abrupt movements of controls.

In any normal dive always keep the airplane trimmed by use of trim tabs. If you attempt to hold forward elevator pressure without the use of trim tabs or against opposite trim, sudden relaxing of this pressure may, because of the extreme leverage action, cause buckling of the fuselage. It is better to trim slightly nose-heavy rather than tail-heavy. If trimmed tail-heavy in a dive, the inherent tendency of the airplane to pull up makes application of up-elevator easier and more abrupt, creating large loads.

In an extended dive when airspeed tends to build up too much, reduce power as necessary but don't pull it entirely off longer than necessary. This would allow the engines to cool down too much.

## Recovery From Dives

For dive recoveries the airplane requires plenty of altitude. In contrast with maintaining a dive, always pull out of dives by manual pressure without the use of trim tabs so that you can feel the amount of pressure you are using. Otherwise you can build up tremendous elevator strain too fast by trimming out of the dive with possible structural failure. It takes a lot of space and a lot of pressure to change the direction of 25 tons of airplane hurtling downward at 200 to 250 mph.

Wait until you have re-established level flight, and then re-trim and advance power to the desired airspeed.

**Combat Emergency:** If, in combat, your elevator control cables were shot away and you were thrown into a dive, you could trim your way out with elevator tabs. Apply trim gradually, because you are using great leverage.

## AIR-SPEED CORRECTION TABLE

### TYPE D-1 PITOT STATIC TUBES.

IAS Instrument Reading MPH	IAS CORRECTED MPH		
	Wing Flaps Retracted	Wing Flaps Extended 20° Down	Wing Flaps Extended Full Down
90	—	—	85
100	—	—	96
110	—	105	107
120	—	116	118
130	127	127	130
140	137	142	139
150	147	150	148
160	158	161	—
170	169	—	—
180	179	—	—
190	190	—	—
200	200	—	—
210	211	—	—
220	221	—	—
230	—	—	—
240	—	—	—
250	—	—	—

### TYPE G-2 PITOT HEADS AND FLUSH-TYPE STATIC HEADS.

IAS Instrument Reading	IAS CORRECTED MPH		
	Wing Flaps Retracted	Wing Flaps Extended 20°	Wing Flaps Full Down
90	—	—	80
100	—	—	95
110	—	109	108
120	—	118	119
130	127	128	129
140	138	139	140
150	148	149	150
160	158	159	—
170	168	—	—
180	179	—	—
190	189	—	—
200	199	—	—
210	209	—	—
220	219	—	—
230	230	—	—
240	240	—	—

# LANDINGS

## DESCENT TO THE LANDING AREA

The B-24 is built for long missions at high altitudes. Just as in climbing or cruising, the descent from altitude can be sloppy or skillful depending on the knowledge and foresight of the pilot.

### Normal Cruising Descent

It saves time, fuel and maintains engine performance to plan your descent ahead. Two factors govern a normal descent: distance from the landing area, and desired rate of descent.

In a normal cruising descent the object is to come down at the rate of approximately 200 feet a minute, using normal cruising power settings, so that you will arrive at an altitude 500 to 1000 feet above traffic as you near the landing area. It is poor planning and wastes fuel to arrive above the field 6000 to 10,000 feet high and then chop power and come down like an elevator. You waste time over the field and cool the engines too rapidly.

### Good Procedure

1. Plan your descent. To come down 10,000 feet at 200 feet a minute would require 50 minutes. In that case you would start your descent about an hour out from the field. From 20,000 feet you would start descending 1 hour and 40 minutes out.
2. Lower the nose to establish the desired rate of descent. It isn't advisable to exceed 200 miles an hour.
3. Trim to maintain a steady, constant rate of descent. To increase the rate of descent, reduce power. This avoids building up excessive airspeed. With this procedure you are getting greater efficiency from fuel, saving time, and placing minimum strain on the airplane.

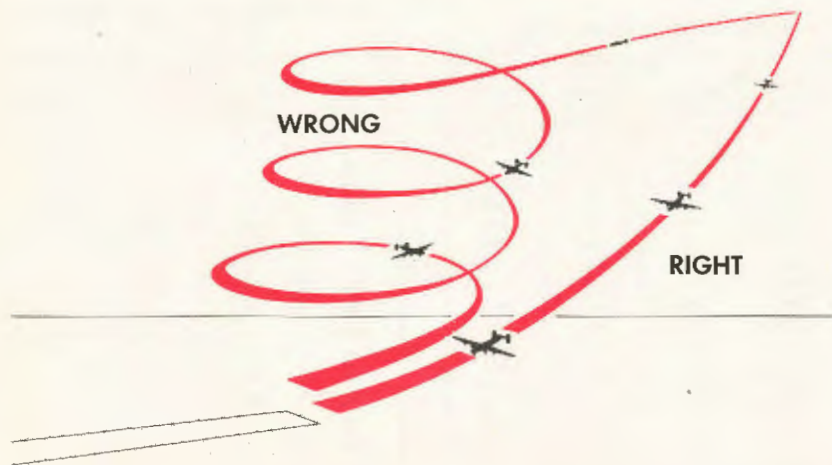

**Reminders**

1. **Oxygen.** Stay on oxygen until you get below 10,000 feet.

2. **Booster Pumps.** Turn off below 10,000 feet to prevent overheating and to increase their life.

3. **Cowl Flaps.** The increased airspeed will tend to lower the cylinder-head temperatures so you should be able to close cowl flaps if they were open during cruising.

4. **Intercooler Shutters.** Make sure they are open. (See Carburetor Icing.)

5. **Manifold Pressure.** You may want to reduce power when descending. In a cruising descent, however, you would maintain a constant manifold pressure during the descent. If equipped with manually operated turbos and if you have some boost on, it will be necessary to slightly advance turbo controls to maintain manifold pressure while descending until you arrive at an altitude where your internal blower will provide sufficient manifold pressure. At this point, turbos may be pulled all the way off. After that, you'll get a rise in manifold pressure as altitude decreases and will control it by reduction of the throttles.

If equipped with electronic turbo controls, the manifold pressure will be automatically maintained down to an altitude where increase in atmospheric pressure allows internal blower to provide sufficient manifold pressure. At this

point turbo control may be dialed back to zero and power controlled from then on by throttles.

6. **Airway Traffic Control Rules.** Keep them in mind during your descent.

**Quick Descent Without Exceeding Airspeed**

When it is necessary to make a quick descent, don't point the nose down and dive at excessive airspeeds. A good method is to reduce manifold pressure to 18" or 20" and bring the indicated airspeed down to 160 mph before lowering the nose. Don't lower the nose before you have dissipated airspeed or the inertia of the B-24 will keep you moving at high forward speed. Hold approximately 160 mph.

If you want a faster rate of descent, maintain this airspeed and further reduce power. For a slower rate of descent, increase power and maintain the same airspeed. Control your airspeed by raising or lowering the nose. Trim to maintain attitude with ease. This gives you a descent controlled by power which will prove valuable in instrument approaches. It gives you lower forward speed, better control, reduces the turning radius and relieves control pressures.

**Cold:** In cold weather, after you reduce manifold pressure, increase rpm to approximately 2400. This will keep the engines warm.

**Warning:** Never make a long power-off descent. This cools the engines too quickly and may result in turbo warping, or in possible engine failure when you resume power.

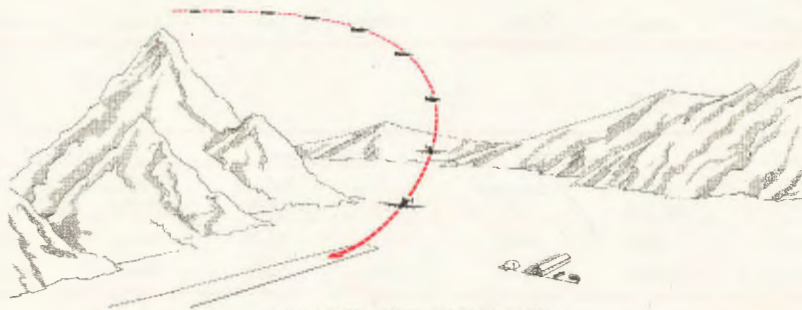

QUICK DESCENT WITHOUT EXCEEDING AIRSPEED

## RESTRICTED

### Approaching the Landing Area

When your descent is completed and you are in the vicinity of the landing area, restore normal rpm and manifold pressure unless you are going directly into the traffic pattern. Notify the tower of your position and obtain altimeter setting and landing instructions.

### Strange Fields

When clearing for strange fields you, of course, ascertain in advance that runways are of suitable length and condition to accommodate a B-24, and that you can obtain the type of fuel and service necessary. However, weather or emergencies may force a change of flight plan to a strange field. Check carefully with the tower before you land as to the length of runways and the type of surface. A difference in the surface alone can lengthen your landing roll as much as 1000 feet (see Landing Table). It may be better to ask permission to use a runway that is quartering or crosswind rather than

a shorter runway into the wind. At a strange field it is a good idea to fly over the field 500 feet above traffic to look it over and note obstructions.

## TABLE OF DISTANCES

This table is useful both for reference and comparisons. Figures used are average based on no wind and standard temperatures. **Example:** To land a 50,000-lb. airplane on a hard surface runway with a field elevation of 3000 feet over a 50-foot obstacle, you should have a ground roll of 2610 feet and a total distance of 3140 feet between the obstacle and the end of the ground roll, with moderate braking from point of contact.

## LANDING DISTANCE (In Feet) B-24, D, E, G, H, & J

### HARD DRY SURFACE

Gross Weight in Lb.	At Sea Level		At 3000 Feet		At 6000 Feet	
	To Clear 50' Obj.	Ground Roll	To Clear 50' Obj.	Ground Roll	To Clear 50' Obj.	Ground Roll
40,000	2365	1885	2640	2250	2960	2470
50,000	2940	2410	3140	2610	3380	2850

### FIRM DRY SOD

Gross Weight in Lb.	At Sea Level		At 3000 Feet		At 6000 Feet	
	To Clear 50' Obj.	Ground Roll	To Clear 50' Obj.	Ground Roll	To Clear 50' Obj.	Ground Roll
40,000	3300	2820	3620	3140	3940	3460
50,000	3920	3490	4240	3700	4560	4040

NOTE: For ground temperatures above 35° C (95° F), increase approach IAS 10% and allow 20% increase in ground roll.

**Comparison:** It requires 500 to 600 feet more ground run at a 6000-foot field to land the same weight airplane on the same kind of surface. Everything else being equal, you may need as much as 1200 feet more ground roll on sod than on concrete. A difference of 10,000 lb. in weight alone can increase your ground roll as much as 400 to 600 feet. These are average figures based on no wind and will vary with wind and air density. However, they show the

importance of considering every factor before deciding to try to land at a strange field.

**Caution:** Just because you or somebody else got into a field last week doesn't mean you can do it today. How much did the airplane weigh, what was the direction and velocity of the wind, and what was the air density compared to conditions today? One serious variation can make hundreds of feet of difference in distance required.

## LANDING CHECKS AND TECHNIQUES

Consistently good landings in a B-24 require a combination of good judgment, good technique and good timing. Although there are quite a few things to do on a landing, you can time your cockpit operations so that you are free at the right moments to concentrate on flying the airplane.

Bear down on your technique and keep it sharp. When you get your own plane and crew,

you'll want to grease every landing to keep the old bus in good shape for the next flight. The key to good landings regardless of the weight of the airplane is "control with power." A heavy airplane is not a floating or gliding type. Power takes you off and it's the proper use of power that will let you down easy at reasonable speed. **Don't forget that!** It applies to every type of B-24 landing.

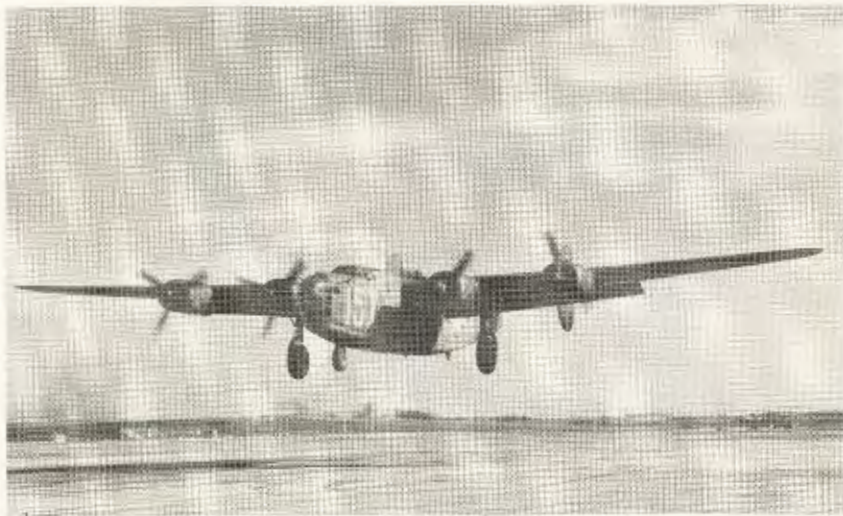

## RESTRICTED

### Location of Downwind Leg

Establish your downwind leg 1 to 3 miles out from and parallel to the landing runway. Fly a reciprocal gyro heading. In strong winds it is usually desirable to set the downwind leg closer to the field; this will shorten the base leg and prevent excessive drift.

## BEFORE LANDING

### Amplified Checklist

Reduce your indicated airspeed to 160 mph as you enter traffic. Start your before-landing check early enough to complete it by the time you are opposite the tower on your downwind leg.



#### 1. Copilot: "ALTIMETER SETTING?"

Before you enter traffic, copilot calls the tower for altimeter setting and landing instructions.

Pilot: "Altimeter set and landing instructions received!"

#### \*2. Copilot: "CREW TO STATIONS?"

Engineer checks that the nose section is clear of passengers and crew. He also directs that the ball turret and trailing antenna be retracted.

Engineer: "Crew in landing positions!"



#### \*3. Copilot: "AUXILIARY HYDRAULIC PUMP?"

Engineer turns it on and signals "On." He continues back to the waist to check the

main gear down and locked when it comes down.



#### \*4. Copilot: "BRAKE PRESSURE AND PARKING BRAKE?"

Pilot presses pedals, notes pressure, and checks parking brake handle in "OFF" position.

Pilot: "Brake pressure checked and parking brake off!"



#### 5. Copilot: "AUTOMATIC PILOT?"

Pilot checks all switches "OFF."

Pilot: "Automatic pilot off."



#### \*6. Copilot: "GEAR?"

Copilot puts the handle in the up position briefly, to eliminate any load on the gear locks, then puts it down at the pilot's direction, at a speed no greater than 160 mph. When the gear comes down it usually reduces airspeed about 5 mph.

Copilot: "Gear down!"

\*ITEMS WITH ASTERISK FOR SUBSEQUENT LANDINGS.



**\*7. Copilot: "MIXTURES?"**

Copilot (at the direction of pilot) puts them in "AUTO-RICH" positions.

**Copilot: "Mixtures in auto-rich!"**



**\*8. Copilot: "PROPELLERS?"**

Copilot increases rpm to 2400 to permit greater flexibility of power range if required.

**Copilot: "2400 rpm!"**

Increase in rpm will cause a drop in manifold pressure. Pilot should be ready to increase throttles, as manifold pressure drops, to maintain power.

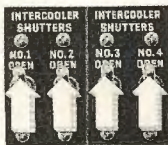

**9. Copilot: "INTERCOOLERS?"**

Copilot checks them open.

**Copilot: "Intercoolers open!"**



**\*10. Copilot: "COWL FLAPS?"**

Copilot checks them for required position.

**Copilot: "Cowl flaps closed (or as required)!"**

**\*ITEMS WITH ASTERISK FOR SUBSEQUENT LANDINGS.**

RESTRICTED



**\*11. Copilot: "BOOSTER PUMPS?"**

Copilot turns them all on to assure adequate fuel pressure during landing.

**Copilot: "Booster pumps on!"**

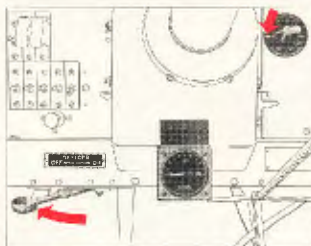

**12. Copilot: "WING DE-ICERS?"**

Copilot checks to make sure they are off. Never land with de-icers on! (See note on exhaust heat anti-icing.)

**Copilot: "De-icers off!"**



**\*13. Copilot: "WHEELS?"**

Pilot and copilot look out to see if they each have a wheel, Pilot: "Wheel left!"; Copilot: "Wheel right!" Pilot checks and reports, "Light on, handle in neutral."

**Engineer: "Gear down and locked!"**

Warning Horn: On final approach, when throttles are retarded to 15" manifold pres-

## RESTRICTED

sure or less, the horn will blow to warn you the gear is not fully down or not locked. But remember that some of the later series aircraft do not have horns.

### 14. Copilot: "BALL TURRET AND TRAILING ANTENNA?"

After the engineer has checked the main gear through the waist gun windows, he proceeds forward to check the ball turret and trailing antenna to be sure they are retracted and the nose gear down and locked. Note: Be sure your engineer knows how to check gears locked.

Engineer: "Ball turret and trailing antenna retracted!"



### \*15. Copilot: "WING FLAPS?"

Copilot lowers them 10°. This increases drag very little at 150 mph but increases lift materially and gives the plane a more level attitude, better visibility and a lower stalling speed.

Copilot: "10° of flaps!"

Airspeed: Be sure your airspeed is 155 mph or less before lowering flaps.

**Before-landing check** should be completed by the time you pass the tower on the downwind leg to leave you free to get ready for the turn on the base leg.

### Get on the Step

Get up on the step just as soon as your wing flaps are down 10°. Remember: Control airspeed with attitude and control ascent and descent with power. If airspeed starts to drop, lower the nose until you are holding the desired airspeed and ease on more power to maintain your desired altitude. Don't jockey your attitude and power so that one correction throws the other off. If the airplane is mushing with nose high and you add power, it will keep right on mushing with only slow gain in airspeed. To regain airspeed and eliminate the mushing effect with the least possible delay, the nose should be lowered slightly as the power is added.

### Time Your Distance Out

You are flying a reciprocal gyro heading parallel to the landing runway. As you pass a point opposite the end of the runway, start timing yourself. Usually you will fly 20 to 30 seconds and then start a standard rate (one needle-width) turn into your base leg. The turn will carry you about  $\frac{3}{4}$  mile farther out from end of the runway this will put your base leg approximately  $2\frac{3}{4}$  miles from the edge of the field. Your heading and turns are controlled

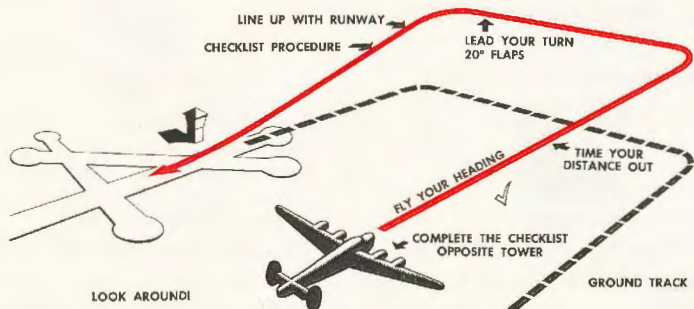

\*ITEMS WITH ASTERISK FOR SUBSEQUENT LANDINGS.



entirely with reference to instruments. Watch your time, and turn on your base leg to make good a gyro heading perpendicular to the landing runway.

#### Base Leg

If you have followed approved procedure, you will be free on the base leg to fly your gyro heading, observe traffic ahead, and look over the approaches to the landing strip. This gives you a chance to judge your distance out from the end of the runway in relation to your altitude. The success or failure of a landing depends largely on a good entry into your final approach.

#### Turning On Final Approach

When to start your turn on final approach is important. The common tendency is to wait too long. Lead your standard-rate turn, approximately  $\frac{3}{4}$  of a mile. Then your rollout will bring you into final approach in line with the runway.

**Half Flaps:** Pilot calls for half flaps just before starting the turn into final approach, and copilot lowers them to 20° position.

**Power Reductions:** As the flaps come down, pilot reduces his power. Pilot should hold a level turn until 20° flaps and reduced power bring airspeed down to 135 mph.

#### Line Up With the Runway

Be sure you are lined up with the runway. If not, rudder over at once before you get too close to the field. You may roll out to the right or left of the runway and you can usually correct this with rudder and little or no bank if you start far enough back.

## FINAL APPROACH

#### Amplified Checklist

As you roll out of your turn lined up with the runway, start your checklist procedure.

**Warning:** Be sure your feet are flat on the rudder pedals and down off the brakes. It takes very little brake pressure to blow your tires when the wheels touch.

RESTRICTED

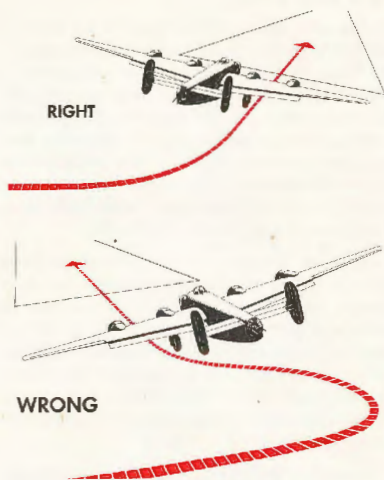

#### 1. Copilot: "PROPELLERS?"

Pilot has reduced power below 25" manifold pressure and now calls for high rpm. Copilot sets propellers in high rpm.

Copilot: "High rpm!"

#### 2. Copilot: "SUPERCHARGERS?"

Pilot sets superchargers at takeoff manifold pressure so that full power will be available if needed.

Pilot: "Superchargers set and locked."

#### 3. Copilot: "FULL FLAPS?"

Pilot calls for full flaps (airspeed 135 mph) and copilot lowers them. This will bring the airspeed down to 125 to 130 mph for the glide.

Copilot: "Full flaps down!"

#### 4. Copilot: "AIRSPEED."

Copilot calls out airspeed every few seconds throughout landing to assist pilot in maintaining proper attitude.

## RESTRICTED

### Make Good a Point

Pick a point about 10 feet short of the runway and line it up with a rivet or reference point on the nose. You are making good this point in your descent if you keep it lined up with the reference point on the airplane. If the point on the ground drops below your reference line, you are overshooting it; if the point moves above the reference line you are undershooting it. Don't try to judge your flight path by a projection of your longitudinal axis.

**Airspeed:** Maintain 125 to 130 mph in your glide. With full flaps down you can control your descent with power. A good, normal rate of descent is 500 feet a minute at 15" to 18" of manifold pressure. If undershooting, increase power to cut your rate of descent; if overshooting, decrease power to increase your rate of descent. In either case, maintain a constant approach airspeed.

**Flare-Out:** Start your flare-out high enough, about 150 feet up. It takes time to change the direction of a 4-engine bomber. Your airspeed will decrease gradually as you gradually raise the nose and reduce power.

### Coordination of Power and Attitude

Your flare-out and reduction of power should be perfectly coordinated. If too high, reduce power; don't steepen your gliding angle and build up excessive airspeed. If you are coming in just right, power should be blended off in

almost perfect coordination with your round-out. If you are flaring out short, let your power lag behind the flare-out to carry you farther in; if you are too high, bring power off a little faster to ease the airplane to the ground more quickly. Properly executed, the flare-out will bring the airplane in just above the runway surface at 105 to 110 mph in a definitely nose-up attitude, sinking at a rate that will grease it into the runway. Power keeps down your rate of descent and prevents the airplane from hitting the runway with a heavy jolt.

## *Avoid these errors*

**Undershooting:** There is a tendency to undershoot because in a normal landing the flight path is much steeper than it seems. Although the nose may be pointed well down the runway, the airplane may be sinking toward a point short of the runway. Pick a point to make good and establish a reference line by which to judge your glide path.

**Dropping In:** The B-24 is not a glider. Don't make the mistake of chopping off all power in the flare-out before your airplane is on the concrete. Let down to the runway with smooth, gradual reduction of power. Otherwise the heavy drag of wings, flaps, and windmilling propellers will cause a sudden loss of airspeed and will drop you in.

**Flying Onto the Concrete:** What you want is power control, not excessive airspeed. If you



come in too fast, you'll have to fly onto the concrete with the nose gear as low as the main gear to get the airplane to stay on the runway. Then, with power off, if you try to kill speed by bringing the nose up, you will take off again, rapidly lose airspeed, stall and drop in from several feet above the ground.

Get the nose up and airspeed down during the flare-out, and control your sink with power. Use correct airspeed, attitude and power control and you've got a good landing.

#### Landing Roll

Hold the nose up with the elevators and maintain directional control with the rudders. In a nose-high attitude the drag of the wings and flaps reduces speed rapidly.

Keep the nose high until it tends to want to come down—usually at 70 to 75 mph. Then lower the nosewheel smoothly to the runway. When the nosewheel is solidly on the ground (and not before), raise your feet into braking position.

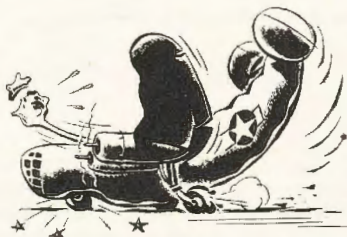

#### Brakes

Feel out the brakes early so you will know what to expect of them. If you have plenty of room, use it and save your brakes, but remember it is better to use brakes too early than too late. Get the airplane slowed down with a reasonable amount of room to spare. Use brakes progressively. Apply them and then release them. Don't sock them on and leave them. And don't leave the weight of your toes on the brakes when not applying them, because the heat generated may crack a drum or burst an expander tube.

#### Clear the Runway

Clear the runway promptly. The pilot behind you may have lost his hydraulic brake pressure and not know it, or may need all the runway.

## CROSSWIND LANDINGS

Crosswind landings in a Liberator present the same problem as in other aircraft except that poor technique produces more serious consequences. The object is to bring the airplane onto the runway with zero drift. Any drift will place a heavy side load on the gear and can result in blown tires or landing gear failure.

In a crosswind landing, fly the pattern just the same as in a normal landing. Line up with your runway on final approach and note your drift. There are 2 approved methods of correct-

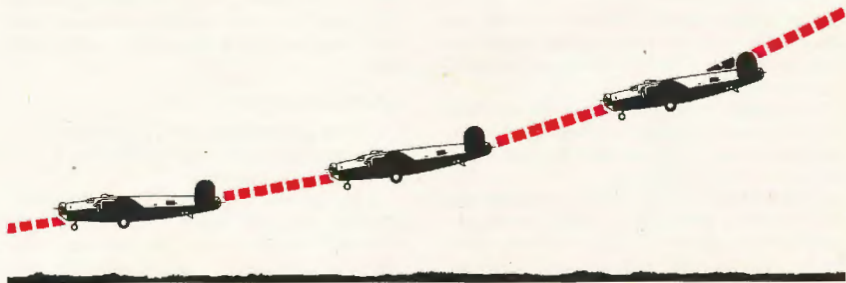

RESTRICTED

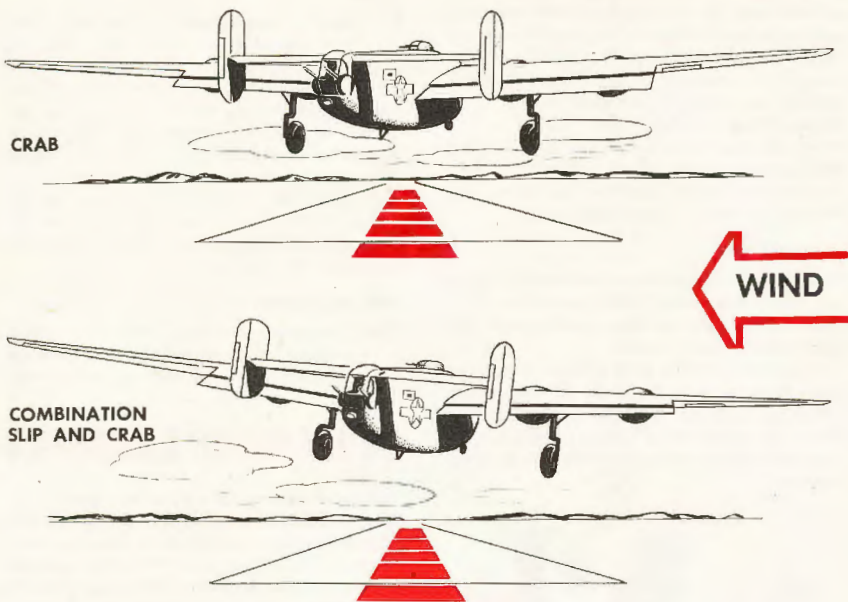

ing for drift, namely: Full crab with wings level, or combination of crab with the upwind wing slightly down.

#### Full Crab Correction

1. Hold your wings level and head the airplane sufficiently into the wind with rudder to fly a ground track directly down the center of the runway path.
2. Approach the end of the runway and flare out in the usual manner. Just before you touch the ground, use rudder to head the nose down the center of the runway.
3. Timing is the thing. If you straighten the crab too soon, you'll start to drift before you touch the runway. If you delay too long, you'll hit the runway while still in a crab. The moment you touch the runway is the crucial one.
4. Remember that when you rudder out of

the crab you are moving the upwind wing rapidly forward, tending to increase its lift, so it will require a little opposite aileron to hold the wings level. It requires perfect timing to execute this type of crosswind landing properly because of the large correction necessary and slow response of the airplane to rudder control.

#### Combination Method

1. Here you correct drift by crabbing and dropping the upwind wing slightly to fly a track in line with the runway.
2. Here's what actually happens. You rudder into the crab, and lower the wing in a coordinated movement and at the same time lower the nose slightly and relax rudder pressure. The result is a crab and a mild slip into the wind. For that reason it is important not to

drop the wing too much because you lose lift rapidly in an uncoordinated bank.

Again be sure your airplane is not drifting as you contact the runway. Usually you can correct the crab and lift the wing almost entirely with rudder, because the forward movement of the upwind wing as it swings out of the crab will lift it. Use no more ailerons than necessary, because ailerons create burble at low flying speeds.

**Warning:** If you see you have taken out the crab too soon and are starting to drift, you have 2 choices: Apply enough power to keep the airplane off the runway and re-establish a non-drifting ground track; or, if that is not possible, apply full power smoothly to go around and try again. Don't take a chance on hitting the runway while you are drifting sideways. The combination type of crosswind landing is most commonly used.

#### **Crosswind Landing Roll**

In either the full crab or combination methods it is a good idea to touch the ground with the nose slightly lower than normal but with the nosewheel definitely clear of the concrete. Bring the nosewheel firmly to the ground as soon as possible.

#### **Tricycle Gear Fights a Groundloop**

The inherent directional stability of the tricycle landing gear overcomes the weathervaning effect of the crosswind on the airplane. Reason: The center of gravity is between the main gear and the nose gear. The force of inertia (or moving weight) is straight ahead, down the center of the runway, and tends to pull the nosewheel back to this line if it starts to veer. Thus inertia fights against a groundloop. In conventional airplanes with the center of gravity aft of the main gear, inertia tends to swing the tail around and aggravate a groundloop.

You can hold the plane straight ahead with rudder control until speed drops down to 70 or

75 mph. As you lose rudder control, a little extra throttle on the upwind outboard engine or slight brake pressure on the downwind side will hold the plane straight on the runway.

Keep flying the airplane. A successful crosswind landing is not completed until the airplane is safely parked on the hangar line.

## **CROSSWIND TAXIING**

When taxiing in a high crosswind, it is difficult to hold rudder neutral. In that case, it will save wear and tear on yourself and the copilot to relock controls before starting to taxi. If so, be sure you unlock them before takeoff. Usually the copilot can hold controls in neutral.

On the average taxi strip you can keep the airplane down the center of the runway in a crosswind by proper manipulation of throttles. When the airplane starts to nose into the wind, apply power smoothly on the upwind outboard engine long enough so the nose will swing past the center line; then pull the throttle off. Meanwhile hold other throttles back. Then let the airplane gradually nose back to the center of the runway and repeat. This produces an S-ing track but permits control without brakes and without building up excessive speed.

Another method is to carry enough constant power on the upwind side to counteract the crosswind. However, this tends to build up excessive speed and requires more frequent use of brakes.

In a severe crosswind or on a narrow taxi strip, it may be necessary to use the downwind brake to hold a straight-ahead path. If so, apply the brake and release it, apply and release. There is danger of destructive heat if you maintain a steady pressure.

RESTRICTED



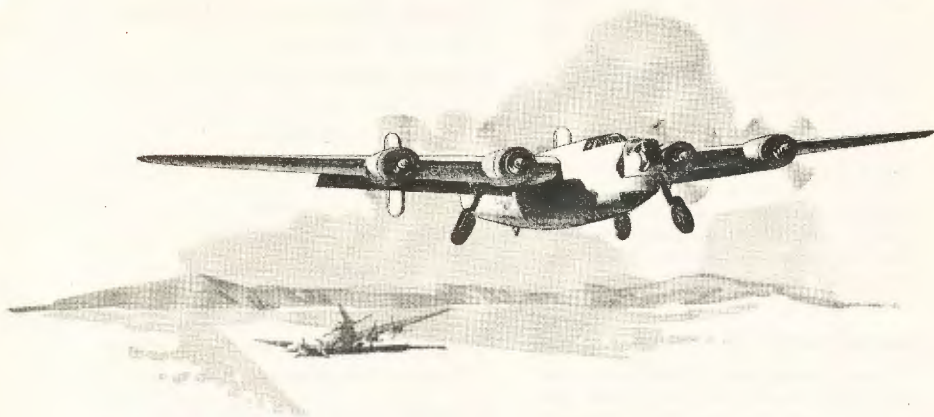

## GO-AROUND

Be ready, on every landing, to go around if necessary. Without warning, it may be necessary for the tower to send you around again because of an accident on the runway, misunderstanding of traffic instructions by another pilot, or other emergency. You may choose to go around because you find yourself too close behind another airplane, because you are overshooting or have made a bad landing. Don't wait too long. The minute you see the need, decide to go around. If you aren't on the ground in the first  $\frac{1}{3}$  of the runway, call for the go-around procedure. Notify your copilot so he knows immediately what you intend to do.

### Amplified Checklist

#### 1. Copilot: "POWER."

As he announces the go-around procedure, the pilot opens throttles to takeoff manifold pressure and re-trims airplane.

**Avoid Jamming:** Don't stiff-arm the throttles. Advance power smoothly and rapidly but no faster than propellers can take it. If you jam power on too fast, it speeds up blades faster

than propeller governors can change pitch so that there is danger of a runaway propeller.

**Trimming:** Re-trim elevators for climb as you increase power. You were trimmed for landing and for reduced power. Increased power will make the airplane tail-heavy until re-trimmed.

**Climb:** You are trying to build up airspeed with full flaps down, so hold a near level-flight attitude with very shallow climb.



#### 2. Copilot: "AIRSPEED."

Copilot watches the airspeed and calls it out to the pilot every few seconds.

#### 3. Copilot: "WING FLAPS."

After the airplane has reached a safe speed (approximately 120 mph) copilot when di-

ected by the pilot, brings the flaps up to 20° and returns flap handle to neutral. Simultaneously the pilot raises the nose enough to maintain lift and altitude. Then he will experience no sink and airspeed will rapidly build up to 135 mph.

**Copilot:** "Wing flaps at 20°."

**Errors:** Stop at half flaps! Don't be distracted and bring flaps all the way up yet. Be sure you have 120 mph airspeed before calling for ½ flaps and don't let the plane sink while flaps are coming up. Raise the nose enough to maintain altitude without reducing airspeed.

#### 4. Copilot: "WHEELS COMING UP."

As soon as the flaps are up to 20°, the copilot will reach over and raise the wheels upon command from the pilot. Don't attempt to raise the wheels until you return the flap handle to neutral. The hydraulic system is designed to perform only one major operation at a time.

**Error:** Don't pull gear up before bringing the flaps to 20° or you'll have to wait the 25 to 30 seconds it takes the gear to retract before you can raise the flaps. Then you would have the drag of full flaps when you could be gaining forward speed and climbing. Thirty seconds is a long time at this point.

#### Check

After you have a safe airspeed, check temperatures and put cowl flaps at trail, if closed. Don't change cowl flaps until you have 135 mph.

## END OF LANDING ROLL

#### 1. Copilot: "SUPERCHARGERS?"

Pilot closes them while taxiing.

**Pilot:** "Superchargers off."

#### 2. Copilot: "BOOSTER PUMPS?"

Copilot switches them off.

**Copilot:** "Booster pumps off."

#### 3. Copilot: "GENERATORS?"

Engineer checks them in "OFF" position.

**Engineer:** "Generators off."

#### 4. Copilot: "WING FLAPS?"

Copilot raises flaps.

**Copilot:** "Wing flaps up."

#### 5. Copilot: "COWL FLAPS?"

Copilot opens them fully.

**Copilot:** "Cowl flaps open."

#### 6. Copilot: "AUXILIARY POWER UNIT?"

Engineer turns this unit on during taxiing because generators will not charge batteries when engines produce less than 1700 rpm.

**Engineer:** "Auxiliary power unit on."

#### 7. Copilot: "BRAKE PRESSURE?"

Copilot checks brake pressure and continues to check it frequently until the airplane is parked. If at any time brake pressure falls below 800 lb., pilot will bring the airplane to a stop and not move it again until brake pressure is re-established or until engineering personnel come to tow the airplane in.

### TAXIING IN

As soon as your landing roll is completed, clear the runway and keep moving, because other aircraft may also want to clear immediately. At strange fields ask the tower for taxiing information. Don't proceed blindly. Tower personnel are there to help you. Ask for clearance before crossing runways. Some fields use 2 runways at the same time. Don't forget to post an observer.

### PARKING THE AIRPLANE

There isn't any hurry. Wait for directions if not fully familiar with the parking area. Get a ground man out in front and one on each wingtip. Remember that you are the airplane commander, and if the ground crew rams you into another airplane or tries to put you into a space that's too small, you'll get the blame. If in doubt as to clearance, stop the airplane in its tracks.



Don't let a ground-crew man mess up your airplane. Let them put it away with a tug.

After completing the turn into the parking space, roll at least 5 feet forward to avoid parking with the nosewheel at an angle.

Caution: When the airplane is parked don't let any of the crew or passengers leave until the engines are stopped. Issue special instructions to this effect if anyone has been ill during the flight. **Never let anyone walk through the propellers at any time.**

## TO SECURE THE AIRPLANE

### Amplified Checklist

#### 1. Copilot: "ENGINES."

Pilot opens throttles until propellers reach 1000 rpm. Copilot puts mixture controls in "IDLE CUT-OFF"; then pilot opens throttles slowly, leaving them fully open.

Copilot: "Mixtures in idle cut-off."

Pilot: "Throttles fully open."

#### 2. Copilot: "SWITCHES."

Copilot closes all switches after propellers have stopped, first magnetos and radio; then, when autosyn instruments such as oil, fuel, etc., have returned to neutral, he turns off AC power, lights, battery selectors and main line. Don't cut battery selectors and main line until all electrical switches are "OFF."

Copilot: "Switches off."

#### 3. Copilot: "WHEEL CHOCKS?"

Pilot checks left wheel chock and copilot checks right wheel chock in place so brakes may be released, because heat continues to expand the expander tubes. Brakes should be left unlocked until they are cooled off and the crew chief locks them later.

Pilot: "Wheel chock in place left."

Copilot: "Wheel chock in place right."

#### 4. Copilot: "GEAR HANDLE?"

Copilot puts landing gear handle down so that any hydraulic expansion will tend to close the gear lock rather than to open it.

Copilot: "Gear handle down."

#### 5. Copilot: "FLIGHT CONTROLS."

Copilot locks flight controls while pilot loosens the locking strap. Use the following sequence for locking controls: First lock rudder by holding rudder near neutral and slowly moving either way while applying slight tension to the locking handle. Next lock the elevators by moving the wheel to the white line and then slowly back and forth until the locking pin drops in; lock ailerons by moving wheel slightly from side to side until the aileron pin drops in. **Do not force the locking handle.** Then place the hook in the handle and draw the strap up.



Fill out Form 1 and 1A before leaving the airplane and give the engineer full instructions as to servicing.

#### Parking at Strange Fields

Airplane and crew are the airplane commander's responsibility. You can delegate duties but you cannot delegate responsibility. You must arrange for proper servicing, securing and mooring of the airplane. The airplane should be locked and a guard should be posted if there is not regular guard protection, even if you have to hire a civil guard.

Think of your crew's comfort before you think of your own. See that they have a place to eat and sleep; check transportation; arrange for passes to get them in and out of the field, and notify them as to probable takeoff time so they will know when to have the airplane ready. Fair-minded consideration for your crew will build loyalty and crew spirit.

## POWER-OFF APPROACH



A power-off approach proves useful when you see that you are coming in too high or when—in combat, for instance—you find it necessary to make a quick descent over high trees or other obstructions on to a short runway that begins fairly close to the obstruction.

Your approach is normal in all respects except that you pull in toward the field under power, high enough to make certain you will clear the obstacle when you start your glide.

### Glide

From a relatively high position in relation to the end of the runway, retard throttles completely and lower the nose to maintain an air-speed of 125 mph. This will bring you down at a relatively steep angle of glide. Trim to ease fore and aft pressure but avoid over-trimming, or the airplane will have a strong nose-high tendency when you advance throttles.

### Flare-out

Start your flare-out 100 to 150 feet above the ground and at the same time increase throttles to 12" to 14" of manifold pressure to stop the descent and change the direction from down to forward. Remember, you must overcome the tendency of a heavy body to continue moving in the same direction. Coordinate power with your flare-out, first building up power to change

the attitude and direction of the airplane and then, as you near contact with the runway, reduce power to hold forward speed down to 105 to 110 mph. Don't completely reduce power until you make contact with the runway.

Although you are making a power-off approach, you are making a power-controlled landing. Don't try this without power to aid in your flare-out, or you'll keep right on sinking.

## EMERGENCY SHORT-FIELD LANDINGS

Never land a B-24 on a short runway except in absolute emergencies. However, it is important to know the proper technique if an unexpected emergency arises. In combat anything can happen and often does.

### Procedure

1. Execute downwind and base leg in the normal manner.
2. Come in toward the field in a normal manner but shoot for a point several hundred feet short of the runway.

3. Flare out as if you were going to land short of the field but add power as you increase your angle of attack so that the airplane is dragging in 50 or 60 feet up at 105 to 110 mph. Control sink by addition or reduction of power.

4. Reduce power to lower the airplane in a nose-high attitude at a point as near the end of the runway as possible. Pull power completely off as soon as wheels touch, but **not before**. Remember that the only thing which keeps you flying is the thrust from your propellers.

**Error:** Don't build up airspeed by lowering the nose, or the airplane will tend to have excessive forward speed and float, using up too much runway. This defeats the purpose of a short-field landing. The object is to reduce forward speed but maintain control with power.

5. The moment the main gear is on the concrete get the nosewheel down smoothly but quickly and hold positive forward pressure on the wheel to depress the oleo strut fully so braking won't injure the nose gear assembly. There is risk of excessive strain on the nosewheel, so build up forward wheel pressure smoothly and gradually.

6. Immediately start to feel out the brakes, and then use them strongly and intermittently—not continuously unless absolutely necessary.

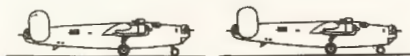

GET NOSEGEAR DOWN  
SMOOTHLY BUT QUICKLY

USE BRAKES STRONGLY  
AND INTERMITTENTLY

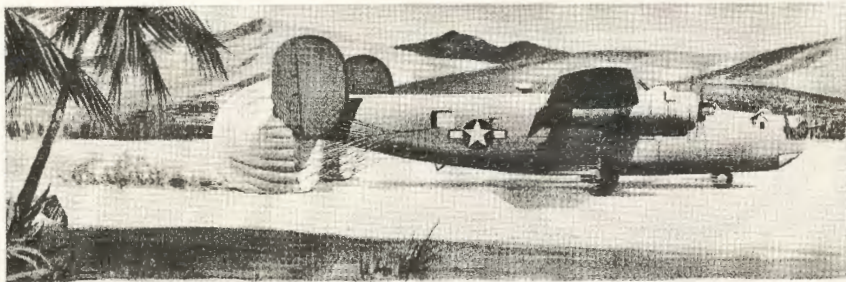

### Advantages

This technique brings the airplane to the concrete as near the end of the runway as possible, at minimum forward speed, and permits the use of brakes quickly. It helps you get maximum benefit from every inch of runway.

**Errors:** If overshooting, go around and come in for another try. If you have slowed down too much to have room to go around, but are running off the end of the runway because the brakes won't hold, you'll have to use quick judgment of what is best to do. Here are 2 possible courses of action:

1. As you roll from the end of the runway, get off the brakes and pull as much weight as possible off the nosewheel. Otherwise it may dig into soft dirt and collapse.

2. If there are obstructions or a drop-off ahead, you may choose to bear down hard on one brake and use a little opposite power to groundloop the airplane.

Don't get yourself in a spot where you have to make a choice of this kind.

### Parachute Brakes

If you ever have to land on a short runway without brakes or flaps, a trick devised in combat theaters may come in handy. Several times B-24's have been landed safely with parachutes slung from the waist gun mounts to provide drag. The procedure has varied, but the general method is to fasten the parachute harness to the gun mounts. As soon as the airplane touches down, the pilot signals crew members—by interphone or by a pre-arranged alarm bell signal—to pull the ripcords. The point of

## RESTRICTED

drag is far enough aft so that you don't need to worry about a groundloop even if one parachute fails to open, but some pilots have had two parachutes fastened on each side, the second being used if the first doesn't open. Still another variation calls for two parachutes on each side to be opened simultaneously. It's all improvisation, so work out whatever procedure seems best; better still, find some one who has seen it done and learn from him.

# LOW VISIBILITY OR CLOSE-IN APPROACH

This approach may be used in case it is necessary to land in a condition of low visibility when the normal traffic pattern would carry you out of sight of the field, when there are no directional radio aids to aid you in making an instrument approach, or in case of radio failure. Also see Low Visibility Approach in T.O. 30-100B-1.

### Procedure

1. Approach the field in the direction you are going to land at traffic altitude or as high as visibility will permit.

2. Check in with the tower, know the exact conditions regarding other traffic, and check your knowledge of the location and altitudes of all obstructions in the vicinity of the field. Complete your checklist, get your gear down and checked, and have an airspeed of 150 mph by the time you reach the field.

3. Fly upwind along the landing runway to the opposite end.

4. Lower the flaps to 20° and reduce airspeed to 135 mph to 140 mph and execute a one-minute timed turn.

5. Fly back on the reciprocal heading and, opposite the approach end of the runway, start timing and fly out for 15 seconds.

6. Reduce power at the end of 15 seconds and start a 1-minute timed turn, descending at the rate of 200 to 500 feet a minute depending upon your altitude. Power reduction will be in proportion to desired rate of descent. Start your final approach checklist halfway through the turn to obtain proper settings of propellers, superchargers, etc.

7. Roll out in line with runway, lower full flaps, and reduce power as necessary.

8. Procedures are the same as a normal landing in all other respects.

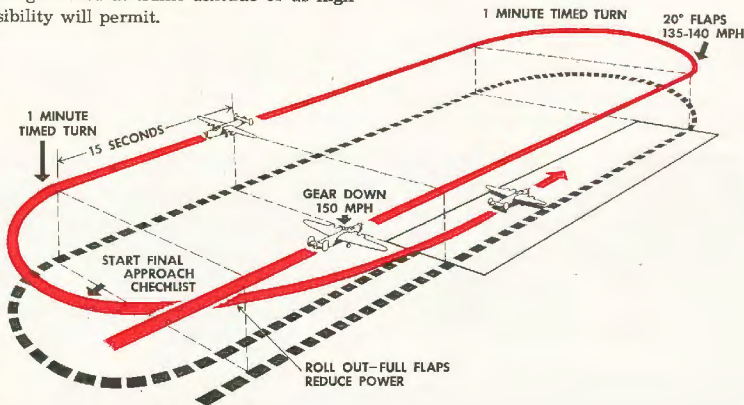

## FORCED LANDINGS

Of necessity, the problem of forced landings not on airports will vary with every situation, and procedure must be left to the judgment and resourcefulness of the pilot. Following are practical suggestions:

1. Radio your position to the nearest facility at the first indication of an emergency.
2. Always drop bombs over uninhabited areas or in enemy territory, and secure loose equipment which might cause injury.
3. Always warn the crew immediately of the emergency by interphone so they will have time to get ready to bail out or to take stations and get braced for a crash landing.
4. Have the engineer turn off fuel sight gage valves and wing compartment drain line valves located in forward bomb bay compartment on lower wing surface near the booster pumps.
5. Bleed the oxygen system if there is time.
6. Retract the ball turret.
7. Have fire extinguishers and first-aid kits handy to facilitate removal after landing.
8. Do not turn auxiliary hydraulic pump on if No. 3 engine is operating. If No. 3 is not operating, use auxiliary hydraulic pump to lower gear and flaps and charge brake accumulators. Then turn it off before contact to reduce fire hazard in case the wing tanks are fractured and leak gas into bomb bays, in vicinity of the open-brush motor.
9. Bail out in preference to making a forced landing at night.

### Positions For Bracing

Flight Deck: Pilot and copilot with safety belts and shoulder harness securely fastened. Others

on flight deck lying down with feet braced against step as much out of the way of the turret as possible.

Half Deck: As many men as possible squeezed on half deck, feet braced against forward part of ship. Remaining men in crash harness or braced near Station 6.

### To Land or Not to Land?

If you have a choice, don't attempt a forced landing unless you are reasonably certain of success.

Over rocky, rough, or excessively soft terrain, always bail out if altitude permits.

It is sometimes possible to make a forced landing on a road or on a long, level, dry, cultivated field.

### Procedure After Landing

1. Remove fire extinguishers and first-aid kits when leaving airplane.
2. Get out as quickly as possible.
3. Count noses and rescue trapped personnel, check injuries and give first aid if needed.
4. Inspect aircraft for fire hazards. Forbid smoking in vicinity of aircraft. Post guard and send word by nearest telephone in accordance with instructions in your flight envelope.

## ALWAYS BAIL OUT THE CREW IF ALTITUDE PERMITS

On any landing where there is serious danger of over-running a short runway or where other circumstances make the landing hazardous, bail out all the crew except the engineer, copilot and pilot if altitude permits. Before doing so, make certain that each crew member understands how to leave the airplane and how to use the parachute. (See Bailout.) It is the positive duty of the airplane commander to hold

**ALWAYS LOWER AND LOCK THE LANDING GEAR,  
IF POSSIBLE, FOR A FORCED LANDING**

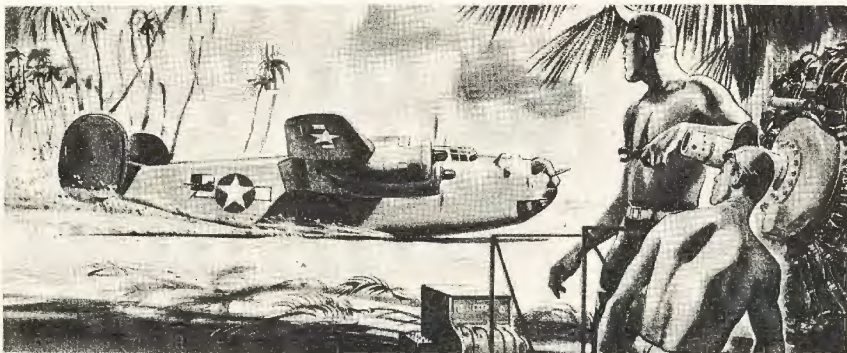

ground drills in the airplane on bailout procedures and emergency bailout signals. Never leave it up to the crew to decide whether they will bail out or not.

#### How to Make a Belly Landing

If all emergency procedures fail to lower the gear, then it is necessary to make a belly landing. Should you land on or off the runway? Experience has shown that with heavy bombardment aircraft such a landing should be made on the runway. The reason is that dirt and sod roll up into balls, fracturing the plane's skin; then the bottom surfaces serve as a scoop.

Fear of fire has caused pilots to dislike the idea of belly landings on concrete. If the gas system is intact and not leaking, such fears are largely groundless. Moreover, the airplane will stop as quickly or more quickly on concrete than on sod.

#### Procedure

1. Bail out all crew members except the engineer, copilot and pilot.

2. At the earliest moment notify the tower of your position, that it may be necessary to make a belly landing on the runway, how much longer you intend to remain aloft and approximately where and when crew members will bail out.

Pilot and copilot should securely fasten safety belts and shoulder harness to avoid being

thrown forward on the wheel on impact and thus forcing the nose down. Warn the engineer to brace himself in a position clear of the top turret in case it should fall on impact.

3. When you are sure you must make a belly landing, release bombs in "safe" position over uninhabited areas at not less than 500 feet.

4. Have the engineer turn off the fuel sight gage valves and wing compartment drain line valves located in forward bomb bay compartment on lower wing surface near booster pumps; drain the lines through the bomb bay drain valves.

6. Have the engineer check auxiliary hydraulic pump "OFF." Open the flight deck escape hatch, and also open the waist window hatches to permit easy access to the rear of the airplane after landing.

7. Make a normal approach in all respects.

8. Use a normal flare-out and hold your sink to a minimum with power, contacting the runway at 105 to 110 mph. Brace against the impact so you won't shove the wheel forward. Bring the control column back as far as possible and hold it there.

9. Simultaneously on impact copilot should put all mixture controls in "IDLE CUT-OFF" and turn master switch "OFF." This cuts off all switches, batteries, etc.

10. When the airplane stops get everyone out as quickly as possible. Have the engineer bring fire extinguishers along.

## NO-FLAP LANDINGS

This becomes necessary if flaps can not be lowered because of mechanical failure or as a result of enemy fire. The important thing to remember is that no flaps reduce lift greatly and increase the stalling speeds in level flight, in turns, and during flare-out.

### Procedure

1. Maintain an airspeed of 150 to 155 mph approaching the field and in traffic, and use the longest runway wind permits.
2. Make shallow turns because of higher stalling speeds with no flaps.
3. Fly the final approach descent flatter so there is less change of attitude in the flare-out.

Avoid a steep angle of glide. But don't get so low you have to use excess power and build up too high an airspeed in order to drag in.

4. Hold an airspeed of 150 mph on final approach, reducing to 140 mph (for normal load) during the flare-out. Maintain airspeed 15 to 20 mph faster than known stalling speed for the load carried.

5. Plan contact as near the end of the runway as possible. When you are low over the runway, start raising the nose and reducing power very gradually. Carry enough power to keep sink to a minimum, and don't raise the nose to stop sink. Contact the ground at 135 to 140 mph and immediately bring throttles full back.

6. If there is ample runway, raise the nose to slow airplane down. If the runway is short for your speed, immediately lower the nose so that you can start using the brakes.



## LANDING WITH ONE MAIN WHEEL UP, OTHER MAIN AND NOSEWHEEL DOWN

If this landing is executed properly, there is much less damage to the airplane and chance of injury to personnel than in a belly landing. Know and try all emergency means to lower the main gear. If you have plenty of gas aboard, ask the tower to call an expert to tell you how to get the gear down. If you can't get it down, use this procedure:

### Procedure

1. Bail out all crew members except the engineer, copilot and pilot.
2. Choose a runway on which you can groundloop without running into a hangar or parked aircraft, or going over a cliff.
3. Make a normal power approach and trim for a normal landing.
4. Be sure auxiliary hydraulic pump is off after brake accumulators are charged.
5. Land at a speed 5 to 10 mph faster than

usual and use power to keep sink to a minimum. Grease 'er on.

6. Land with the wing on the side of the faulty gear slightly high, and immediately after contact raise this wing still higher and feather the outboard engine on the bad-gear side to reduce drag.

7. As soon as the main gear is solidly on the ground, raise the nose to a high angle of attack to get maximum lift and to reduce speed as rapidly as possible.

8. As lift decreases, the wing on the faulty-gear side and the nose gear will tend to drop. Hold the wing up with ailerons as long as possible; when the wing starts down and touches, use brake on the good-gear side to stop the groundloop, which will seldom exceed 45°. Damage is usually limited to the outboard propeller, wingtip and vertical fin.

## LANDING WITH NOSEWHEEL DAMAGED OR RETRACTED, OR WITH NO BRAKES

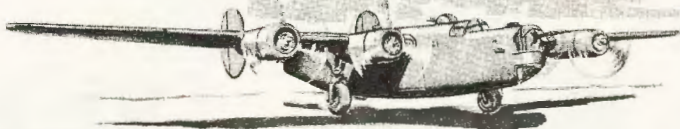

There are a number of situations in which it will be desirable to hold the nose high throughout the landing roll and bring the airplane to a stop resting on the tailskid. Examples: When the nosewheel is damaged or the shimmy damper faulty; when the nosewheel tire is flat; when the nosewheel cannot be extended, or when landing with no brakes.

This procedure requires careful load distribution and precise cooperation from the crew. It is the airplane commander's duty to brief his crew thoroughly on the proper procedure for a landing of this kind.

**Caution** This type of landing is hazardous in a strong crosswind. It is desirable to use the longest runway, but the pilot must use judgment in balancing the benefits of a long runway against the hazard of landing crosswind.

### Procedure

1. Hold the airplane in level flight at 150 to 155 mph (160 mph with nose turret) and shift the load so the airplane will fly level with 1½° nose-down trim. Normally this requires 7 men stationed between the No. 6 bulkhead and the



waist windows. Advise crew in advance exactly what they are to do on landing.



2. Get permission from the tower for an emergency landing. Request the alert crew to stand by and notify tower you will come to a full stop on the runway.

3. On final approach see that crew are all at the predetermined stations in the rear compartment. Carry out the checklist as usual and trim for a normal landing.

4. Land on the main gear at the slowest safe airspeed, controlling sink with power, as near the approach end of the runway as possible. Keep the nose slightly higher than normal but do not land on the tailskid.



5. Hold throttles all the way back, open cowl flaps, and put inboard mixtures in "IDLE CUT-OFF" immediately after landing to get full propeller braking action. If necessary, use outboard engines for directional control or as a last resort for groundlooping if running out of runway.

6. Immediately after contact, raise the nose as high as possible to ease the tailskid down until it is dragging. Trim tail-heavy to hold the tailskid on the ground.



7. The moment the tailskid starts to drag, one crew member will move to the extreme rear of the airplane. Thereafter one additional crew member should move aft for each signal

on the alarm bell. Five or 6 men should be aft when the landing roll has decreased to approximately 20 mph. Send the 6th and 7th men back as the airplane comes to rest.

### *Important*

Emphatically tell men that they are to stay in the extreme rear until specifically ordered out. Several landings of this kind have been successfully made, and as soon as the airplane stopped the crew rushed forward, banging the nose into the ground and doing as much damage as a bad landing.

In case the nosewheel is extended but you have a flat tire, faulty shimmy damper or no brakes, you can lower the nose by calling one man forward at a time from the rear of the airplane to let the nosewheel settle gently to the ground.

## TIRE TROUBLE

Blown tires seldom occur unless the airplane is handled improperly. Then the great weight of a large airplane and the extreme heat generated by improper use of brakes may blow a tire. If this occurs, the inherent directional stability of the tricycle gear is an important aid to the pilot. Following are the best procedures to use in case of a blown tire.

### Blowout on Takeoff

This is usually caused by having the feet up on the brakes during takeoff or braking the wheels too soon after takeoff. Then, if the airplane settles momentarily so that the tires touch, one or both tires may blow out.

If a blowout occurs early in the takeoff run and there is room enough, throttle back and stop. Use brakes with caution, or the flat tire will tear apart and throw rubber all around. Don't let the noise and vibration confuse you.

If you are going too fast to stop, continue the takeoff. With an airplane not too heavily loaded

## RESTRICTED

and good airspeed, you may be able to climb satisfactorily with wheels down. In that case, complete the takeoff procedure in the normal manner—but leave the wheels down to avoid danger of their becoming jammed in the gear wells. Keep 5° to 9° of flaps down for additional lift. You can fly traffic safely at 150 mph.

If you can't make altitude with wheels down, then raise the gear, but be sure the wheels are braked so that loose rubber won't jam in the gear wells. Notify the tower that you are going around for a flat-tire landing.

### Landing With One Main Gear Tire Blown

Repeated successful landings have been made in the B-24 with tires flat and with little or no other damage to the airplane.

#### Procedure

1. Notify the tower that you have a flat tire and that you will make a full-stop landing on the runway.
2. If possible, get permission to use a runway with the wind quartering from the good-tire side. But avoid drift or you'll blow the other tire, too.
3. Cut sink to a minimum. Control it with power.
4. Upon contact, get the nose down as soon as possible, and hold forward pressure on the nosewheel. Then the directional stability of the tricycle gear will help hold the airplane straight.
5. As the airplane slows down it will tend to turn more into the blown tire. Use a little power on the flat-tire side with light braking action on the good tire side to maintain a straight-ahead path.
6. Keep the airplane where it stops until the wheel is changed.

**Note:** Avoid using brakes on the flat-tire side; it will tear the tire up, increase vibration, and won't help in stopping.

### Landing With 2 Main Gear Tires Blown

In this case the procedure is approximately the same as with one tire blown except that you should have the auxiliary hydraulic pump off before contact and land as directly into the wind as possible. Again lower the nose as soon after contact as possible and push the wheel forward, to get the weight forward on the nose-wheel tire and to get the wing at a negative angle of attack. The airplane will vibrate, thump, shake and throw rubber, but you will have good directional control. Stay off the brakes as long as possible. If you must use them, do so sparingly. For added braking action, put inboard engines in "IDLE CUT-OFF."

### Blowout As You Land

If a tire blows out as you land, stay off the brake on that side. Ease the nosewheel down quickly (but never slam it down) and you should obtain directional control. If necessary, brake slightly on the good-tire side and add a little power on the outboard engine on the flat-tire side. The usual mistake is to slam on both brakes too soon. This jerks the nose down and rips the flat tire to pieces. The thing to remember is that you always obtain greater directional control just as soon as you get the nosewheel solidly on the ground. However, in case the flat tire balls up and locks the wheel, it may be necessary to use considerable power and brake to avoid a severe groundloop.

### Nosewheel Tire Blown

See Landing With Nosewheel Damaged or Retracted or Without Brakes.

# POWER PLANT



## DO YOU KNOW YOUR POWER PLANT?

The supercharged power plant of the modern airplane is indeed a complex machine. With automatic devices such as constant speed propellers, electronic supercharger controls, and carburetors for controlling fuel-air mixtures, it is a far cry from the aircraft engine of 20 years ago.

In this discussion of its operation, it is essential first to consider the power plant as a whole, since when one factor in the intricate system changes, other factors—even those apparently remote—may also be affected. For clarity's sake, the discussion will deal chiefly with the electronic turbo-supercharger control, rather than the early type with oil regulated control.

To gain a better understanding of the operation of a supercharged engine, and thus help clear up the existing confusion about manifold pressure and its influence on engine performance, let us first consider the accompanying diagram. It shows the location of the various parts of the power plant which affect manifold pressure during the complete cycle of opera-

tion, and shows how all factors work together to produce the manifold pressure indicated on the instrument panel.

The first unit in the cycle is the air filter. This removes dust and fine sand from the air entering the power plant, preventing the rapid wear such grit would cause on moving engine parts. A slight drop in pressure results from the passage of air through the filter, but when the turbo control is working the turbo compressor rpm is increased to compensate for the drop. At high altitudes, however, you should turn the filters off, or the turbine will reach over-speed at a lower altitude than normal.

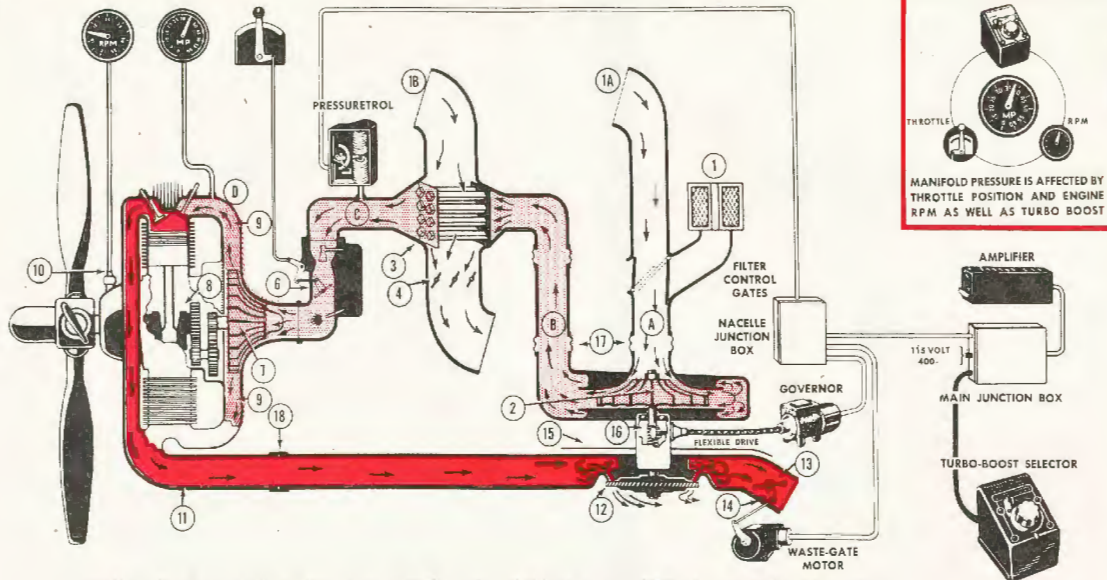

Next is the turbo-driven compressor. The amount of pressure boost it delivers depends upon its rpm and upon inlet pressure. Four factors affect the rpm of this unit: Exhaust pressure in the turbine nozzle box; exhaust gas temperature; atmospheric pressure and temperature, and quantity of air flow through the compressor.

Leaving the compressor, air passes through



**CIRCULAR DIAGRAM OF AN EXHAUST DRIVEN SUPERCHARGER ENGINE**

- |                          |                                  |                       |                       |                             |
|--------------------------|----------------------------------|-----------------------|-----------------------|-----------------------------|
| 1 AIR FILTER             | 4 INTERCOOLER SHUTTERS           | 9 INTAKE MANIFOLD     | 14 WASTE GATE STOP    | A INCOMING AIR PRESSURE     |
| 1A CARBURETOR AIR SCOOP  | 5 CARBURETOR                     | 10 PROPELLER GOVERNOR | 15 HEAT BAFFLE        | B TURBO OUTPUT PRESSURE     |
| 18 INTERCOOLER AIR SCOOP | 6 THROTTLE                       | 11 EXHAUST DUCT       | 16 WORM GEAR DRIVE    | C CARBURETOR INLET PRESSURE |
| 2 TURBO COMPRESSOR       | 7 INTERNAL BLOWER                | 12 TURBINE WHEEL      | 17 FLEXIBLE COUPLINGS | D MANIFOLD PRESSURE         |
| 3 INTERCOOLER            | 8 GEAR DRIVE FOR INTERNAL BLOWER | 13 WASTE GATE         | 18 EXPANSION JOINT    |                             |

- |   |                 |
|---|-----------------|
|  | ATMOSPHERIC AIR |
|  | COMPRESSED AIR  |
|  | EXHAUST GASES   |

RESTRICTED

RESTRICTED

the intercooler. Since this is an integral part of the induction system, a pressure drop occurs here whether the intercooler shutters are open or not. For full power conditions, this drop amounts to approximately 1" Hg.

The regulator sensing unit, or Pressuretrol, is connected to the induction system between the intercooler and the carburetor. It reacts to the carburetor inlet pressure (CIP), or upper deck pressure. This **not the manifold pressure**, is the pressure the pilot selects with the turbo boost selector (TBS), which operates through the Pressuretrol to control the waste gate position and produce the required CIP. (On the old type oil regulated turbos, there is no Pressuretrol, and the CIP has no effect on waste gate setting.)

Since the regulator reacts to the CIP, it is important that the ducts and joints of the entire system be tight. Remember that altitude increases the pressure difference between the inside and outside of the system; a leak that is not apparent during ground operation or at low altitude will cause a greater pressure loss at altitude. Leaks will cause excessive "droop" and unstable power, and will make the turbo overspeed control cut in below the normal altitude.

The next unit in the system is the carburetor, where the position of the throttle controls the manifold pressure. When the throttle is at its optimum position (offering minimum resistance to air flow), the manifold pressure will be at a maximum if other factors do not change. The optimum position of the throttle butterfly is not wide open, but several degrees from this point. Opening it beyond the optimum position may cause an instability and loss of manifold pressure. If the open-throttle stops are set so that the throttle cannot open to the optimum position, an excessive pressure drop will exist across the carburetor. In order to obtain take-off power, the regulator would have to be re-calibrated to give a higher induction pressure. (The regulator should not be re-calibrated to offset incorrectly adjusted throttle stops, however.) This condition will exist at all altitudes and will cause the turbine to overspeed at a lower altitude.

RESTRICTED

Another function of the carburetor is to regulate the mixture of fuel and air, maintaining the weight ratio constant in the normal operating range. Manual mixture adjustment is provided for high and low power conditions. Changing from automatic rich to automatic lean doesn't affect manifold pressure appreciably, but excessive carburetor inlet pressure affects the mixture. Carburetors on B-24 airplanes are designed to maintain a constant fuel-air ratio for variable inlet pressures up to 31" Hg. Above this pressure the mixture becomes lean; if carried too high, this causes detonation and high cylinder-head temperatures.

The next unit in the system is the internal blower. Since this blower is driven directly by the engine, any change in engine rpm causes the blower speed to change. This causes a change in the boost added to the lower carburetor deck pressure to give the indicated manifold pressure.

At higher engine speeds with wide open throttle, the boost from this blower is a large part of the total manifold pressure, and a small change in engine rpm, resulting from a sluggish propeller governor, will bring a noticeable change in manifold pressure. (This effect is common in low temperatures, which cause the oil in the propeller dome to congeal and slow the rate of change in prop pitch. You can correct this by working the prop governor back and forth a few times to send warm engine oil through the dome.)

If the engine rpm is reduced excessively, the turbine will have insufficient gases to operate on and a complete collapse of the cycle may occur. This gives the impression of improper turbo-supercharger regulation. When it occurs, the engine rpm should be increased.

The next part of the system is the intake manifold, which obviously must be leak-proof if you are to get stable pressures. The engine itself comes next. Since manifold pressure depends upon a uniform flow of exhaust gas to drive the turbine, it follows that any flaw in engine operation—faulty valve action, faulty ignition, or changes in rpm—will alter the manifold pressure by causing fluctuations in exhaust pressure. Ignition is a common cause

## RESTRICTED

of unstable manifold pressure at altitude, because decreased atmospheric pressure leads to increased leakage throughout the electrical system. The ignition system must be in perfect condition to offset this tendency at altitude.

The exhaust duct, turbine, and waste gate complete the supercharger system proper. The position of the waste gate controls the speed of the turbine by determining the amount of exhaust back pressure and, consequently, the amount of exhaust flow through the turbine wheel. The TBS knob and the Pressuretrol, as already explained, act upon the waste gate motor to control the position of the waste gate by reference to CIP. A further control of turbine speed is exercised by the overspeed control feature of the governor.

The parts of the regulating mechanism which can cause hunts in manifold pressure are the governor and the Pressuretrol. Improper functioning of these units will be evident at all altitudes whenever boost is being used.

To prevent turbine speed from overshooting its limit during power changes at altitude, the overspeed control opens the waste gate rapidly

to relieve exhaust back pressure, and then closes it at a slower rate to establish the limiting turbo speed. Since turbine speed, instead of pressure, is controlled, a slight instability in manifold pressure will exist at higher powers. The fluctuation warns you when the overspeed control takes effect.

**Note:** Manifold pressure should be reduced slightly whenever the overspeed control goes into operation. The device is designed to work when the turbine reaches maximum rated speed plus 10%. This overspeed rating should be limited to 5 minutes, as continued operation would greatly shorten the life of the turbine wheel. Reduce the turbine rpm about 10% by reducing manifold pressure approximately 1.5" Hg, and continue to reduce it by 1.5" for each 1000 feet you climb above that point.

The foregoing discussion is a general explanation of how your engine works. The material which follows deals in greater detail with the individual parts of the power plant.

### Turbo-superchargers

The turbo-superchargers are installed behind the mount support of each engine, below the

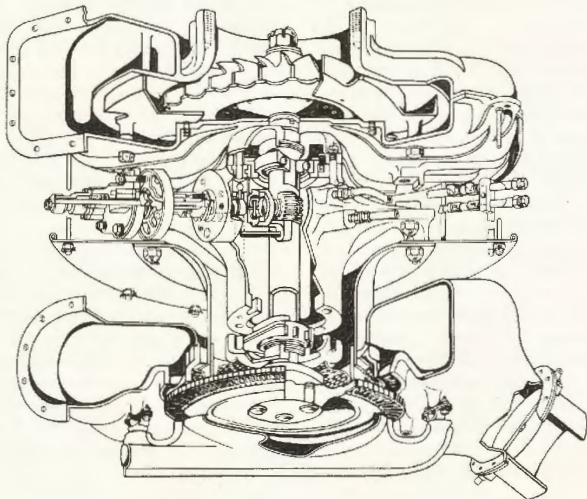

wing's lower surface. On early series B-24's, type B-2 turbos are used, while late B-24's have type B-22 turbos. The two types are almost identical in appearance, but differ in their limitations.

The B-22 has a higher maximum rpm, and therefore a higher critical altitude, than the B-2. At normal rated power—2550 rpm and 46" Hg.—the B-22 has a maximum wheel speed of 24,000 rpm, compared to 21,300 rpm for the B-2. At military power—2700 rpm and 49"—these speeds rise to 26,400 for the B-22 and 22,400 for the B-2, but use of this power is limited to 5 minutes. Because of the greater wheel speed, the B-22 turbo has a critical altitude of 30,000 feet, as against 27,000 feet for the B-2 turbo.

When you reach the critical altitude of the type of turbo you are using (or when the over-speed control takes effect on the B-22 type, producing fluctuations in manifold pressure), reduce manifold pressure 1.5" for every additional 1000 feet you climb at maximum manifold pressure. If you are climbing at less than the maximum pressure, you can raise the critical altitude 1000 feet for each 1.5" that your manifold pressure is below the maximum. Thus, if the critical altitude is 30,000 feet at 46", it will be 32,000 feet at 43", etc.

**Controls:** The superchargers are regulated either through the engine oil pressure system or by electronic control. With the oil-regulated system, used on early B-24's, the pilot regulates the turbos by means of 4 levers on the left side of the pedestal. The levers control the operation of the waste gates on the 4 engines through the oil type regulators.

The electronic control is used on all late B-24's and is replacing the oil-regulated type on most early aircraft. In this system, the TBS knob is the manual control unit. It is mounted on the pilot's pedestal in the space formerly occupied by the 4 turbo levers. The TBS unit contains 4 small calibrated potentiometers which require adjustments only to compensate for small differences in engine or turbo performance. Once the calibrators are set, the pilot controls the turbo boost on all 4 engines simultaneously by turning the control knob.

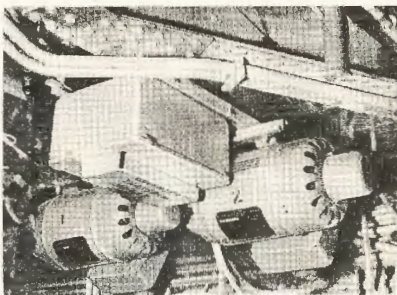

#### Electric Energy

The source of all electric energy used by the turbo-supercharger control system is one of the airplane's 400-cycle inverters mounted under the flight deck, on the right side. Although 2 such inverters are installed in the airplane, only one is used at a time. Either inverter supplies the 115-volt, 400-cycle alternating current needed by the electronic control system.

#### Intercoolers

Heat from compression of the air by the turbo-superchargers must be dissipated before it reaches the engine; otherwise, the normal carburetor intake temperature limits will be exceeded. This is accomplished by intercoolers or radiators in the air intake duct between the turbo-supercharger and the carburetor. Shutters on the intercoolers are provided to regulate

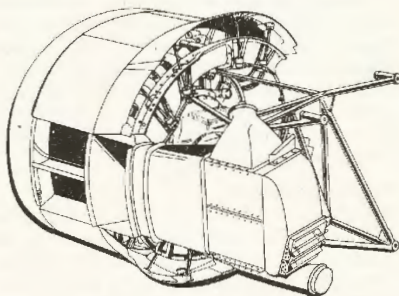

## RESTRICTED

the carburetor air temperature. The shutters have 2 positions—full open and full closed. Extreme caution should be exercised when using intercooler shutters, and carburetor air and cylinder-head temperatures must be watched closely.

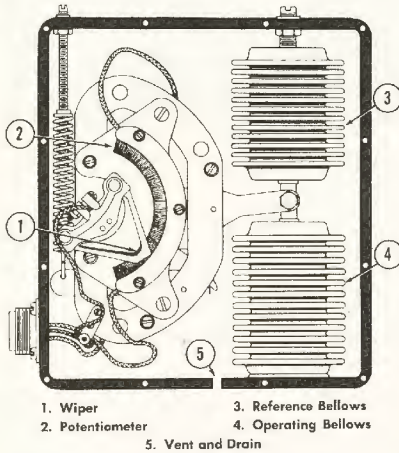

### The Pressuretrol

Control of the pressure in the induction system is accomplished automatically by the Pressuretrol. This unit measures electrically the pressure of the air supplied by the turbo-supercharger to the carburetor, and controls the automatic operation of the system to maintain whatever manifold pressure the pilot has selected, regardless of the changes in the atmospheric pressure caused by variations in the airplane's altitude. It consists of a voltage-dividing potentiometer operated by a pair of bellows, connected to the induction system near the carburetor inlet.

### The Turbo Governor

The governor is a dual safety device driven by a flexible drive shaft which is geared to the turbo-supercharger. One part of the mechanism, called the overspeed control, prevents the turbo from exceeding its safe operating speed

limit. The other part, the accelerometer, anticipates the pressure increase from turbo acceleration and provides a signal to start opening the waste gate in time to prevent the overshooting of manifold pressure.

### The Amplifier

The amplifier is an intermediate unit between the control units and the waste gate motor. It receives two kinds of signals from the other control units. One kind calls for rotation of the waste gate motor to close the gate; the other, for rotation to open it. After amplifying the signal, the amplifier determines the direction of movement called for and controls the power delivered to the waste gate motor accordingly.

If the amplifier of any one of the 4 turbos fails, the waste gate remains fixed in the position it held when the amplifier went out. It is possible, however, to adjust all 4 turbos to any desired manifold pressure even if only one of the 4 amplifiers, or the spare, is working. To do so, it is necessary to disconnect the cannon plugs from the amplifiers (accessible from the

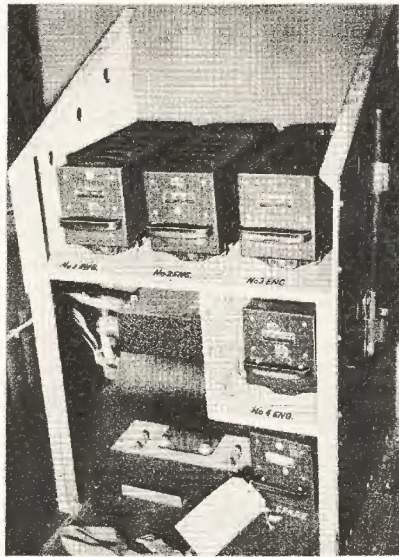

RESTRICTED



bomb bay). Then remove the dead amplifier for the turbo you wish to set up, and replace it with the good amplifier, reconnecting the cannon plug. (The pilot must be on the alert for any turbo fluctuations, keeping his hand on the throttle to control sudden changes, until the amplifier warms up.) From that point on, the procedure is normal, except that when the turbo is properly set up, the cannon plug is again disconnected, freezing the waste gate in

the desired position. This procedure can be used in flight or, if necessary, to set up desired power for takeoff.

**The Waste Gate Motor**

When the waste gate motor operates the waste gate in response to the control signals, it also operates a balancing potentiometer which produces a signal opposed to the original control signal. When the rotation of the motor is enough to make the 2 signals exactly neutralize

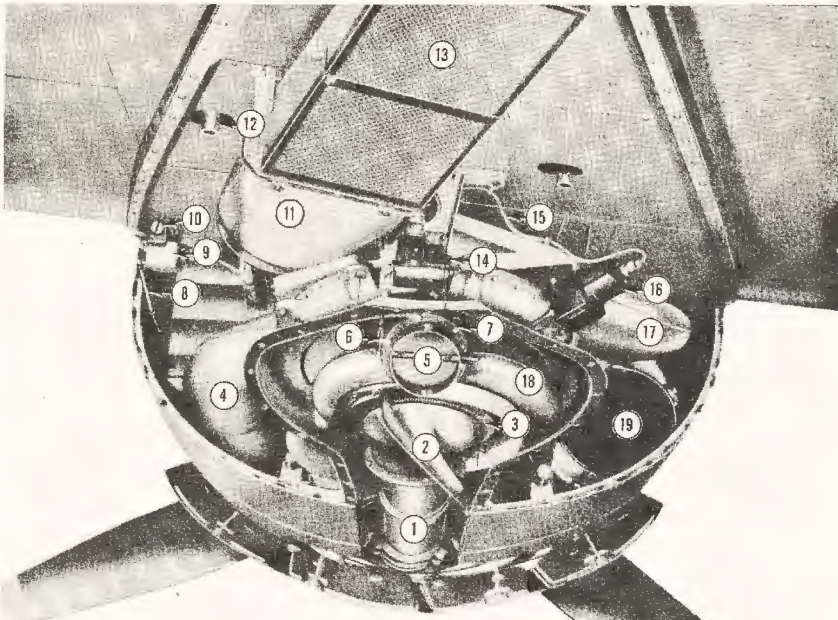

**TURBO-SUPERCHARGER AND REGULATOR SYSTEMS**

- |  |  |
|--|--|
| 1. Exhaust Tail Pipe                         | 11. Turbo-supercharger Alternate Air Intake Duct |
| 2. Turbo-supercharger Cooling Cap            | 12. Auxiliary Wing Fuel Tank Manifold Connection |
| 3. Turbo-supercharger Bucket Wheel           | 13. Alternate Air Intake Filter Box              |
| 4. Air Duct from Supercharger to Intercooler | 14. Waste Gate Control Motor                     |
| 5. Exhaust Waste Gate                        | 15. Electric Cable                               |
| 6. Waste Gate Control Linkage                | 16. Turbo Regulator Governor                     |
| 7. Exhaust Tail Pipe Outlet                  | 17. Turbo-supercharger Air Intake Duct           |
| 8. Intercooler Shutter Control Linkage       | 18. Turbo-supercharger                           |
| 9. Intercooler Motor Control Box             | 19. Oil Cooler                                   |
| 10. Intercooler Motor                        |  |

## RESTRICTED

each other, the power from the amplifier is cut off, and the waste gate motor stops.

### Operating Instructions

#### Electronic Turbo Control

1. Engage the System—After turning on the airplane's battery switches, the main line switch, and one inverter switch, allow 2 minutes for the amplifier to warm up. The control system will then respond to the setting of the turbo boost selector.

2. Before Starting Engines—Set turbo boost selector at "0." Turn on auxiliary power unit. Warning: Never turn inverter off while engines are running, since the control system is dependent on the AC power for operation.

3. Taxiing—Set dial at "0" unless turbo boost is needed.

4. Engine Run-up—Set propeller governors for takeoff rpm and check the manifold pressure on each engine separately by advancing throttle to full open position. Then turn dial of turbo boost selector to the desired position ("8" with Grade 100). If the manifold pressure on any engine fails to come up to within 1" of the takeoff pressure with full rpm, turn dial to "0" and check the engine rpm and manifold pressure without turbo boost. This will show whether the low manifold pressure is caused by faulty engine operation or by insufficient turbo boost. Also check DC voltage on the voltmeter, with generators on.

Note: If engine does not attain full takeoff rpm, manifold pressure will be correspondingly less. (A 100 rpm deficiency in engine speed will produce 1½ inches drop in manifold pressure.)

5. Takeoff—Turn turbo boost selector to desired position ("8" with Grade 100) and then open the throttles.

Note: Be sure generators are on and operating during and after takeoff; otherwise complete electrical failure may result from low batteries causing failure of electronic control.

6. Climbing—After takeoff, turn knob counterclockwise until desired manifold pressure is reached. Decrease rpm to desired value. Re-set manifold pressure with turbo boost selector if necessary. For climbing after cruising, increase rpm first; then advance throttles and increase manifold pressure to the desired value by turn-

ing turbo boost selector clockwise.

7. Cruising—Use dial to select manifold pressure. If manifold pressure cannot be lowered sufficiently with the knob, pull back on the throttles. Decrease rpm to desired value, and then, if necessary, re-set the manifold pressure with throttles and dial.

If icing conditions prevail, close intercoolers and operate as close to full throttle as possible. If ice has already formed (indicated by reduced manifold pressure) open throttle and increase power settings until manifold pressure returns to normal. Watch cylinder-head temperatures closely when intercooler shutters are closed.

8. Emergency Power—Use only with Grade 100 fuel. Put mixture in "AUTO-RICH." Increase rpm to maximum. Open throttles to the stops. Press dial stop release and turn dial clockwise to "10."

Caution: Use only under extreme emergency conditions.

#### No-boost Ground Run-up

The check recommended in Item 4 of the foregoing procedures is an important step in determining engine efficiency, and as such calls for fuller explanation. In a normal ground run-up, engine speed is increased by advancing the throttle, with the prop remaining fixed at minimum pitch. Since prop pitch does not change, engine rpm above 1200 increases directly with manifold pressure. At full throttle, maximum rpm, the boost from the internal blower is a major factor in manifold pressure. Any engine deficiency which reduces horsepower also reduces rpm, and in turn causes manifold pressure to fall off and further decreases horsepower and rpm. The no-boost run-up, therefore, serves as a good indication of the condition of the engine when the manifold pressure and rpm are compared to those of an engine known to be operating properly. In making the comparison, it is important to take atmospheric pressure and wind direction and velocity into consideration. Because of the change in prop loading, a rise in wind velocity from zero to 25 mph may alter engine speed by 50 rpm. In the range of engine speeds above 1400 rpm, rpm may be changed by altering prop pitch, keeping the throttle position fixed.

**Overspeeding Turbo-supercharger**

This occurs infrequently but usually on take-off. An overspeeding turbo is evidenced by the manifold pressure quickly going sky-high. A turbo can overspeed during takeoff and then settle down immediately afterward and continue to operate normally.

If you know a turbo is overspeeding during the first third of takeoff, it is best not to take off if you have room in which to stop.

**Remedy With Electronic Control**

Don't feather with an overspeeding turbo. Reduce manifold pressure with throttle. You can't dial back supercharger setting or you will lose manifold pressure on all 4 engines.

With the electronic supercharger control, a runaway supercharger is usually directly traceable to amplifier failure or insufficient electric power. Amplifier tubes control the opening and closing of the waste gate, and if the tube that controls opening of the waste gate is burned out, the supercharger may overspeed. There is a spare amplifier aboard and it can be changed as soon as you reach a safe altitude.

Caution: Reduce power on the affected engine when changing the amplifier, if circumstances permit, and give it 2 minutes to warm up. Then you can resume power.

Never shut the inverter off for any length of time without reducing power before bringing inverter on again. (Avoid turning inverter off unless in an emergency.)

**Remedy With Oil-Regulated Control**

On the oil-regulated type turbo, overspeeding usually results from clogging of the regulator balance lines or from congealed oil. The tendency to overspeed will usually be evident when you are setting turbos during run-up.

Don't feather. You are getting power from the engine, and you can use it. For the first step, you have two choices. Either pull back the supercharger control or reduce throttle to the desired manifold pressure. Reducing throttle is better because if the supercharger settles down after takeoff, it is easier to re-set the throttle than the supercharger control.

If the turbo wheel continues to overspeed

with throttle retarded, pull back the supercharger control and control power with throttle.

**Carburetor and Mixture Controls**

The R-1830-43 engine is equipped with the Bendix Stromberg injection carburetor. The R-1830-65 engine has the Chandler-Evans Company (Ceco) carburetor. Metering of the fuel is accomplished by air flow through the carburetor venturis. Four positions of the pilot's mixture control lever can be used in operating the Bendix Stromberg carburetor: "IDLE CUT-OFF," "AUTO-LEAN," "AUTO-RICH," and "FULL (EMERGENCY) RICH." With the Ceco carburetor, only the first three of these positions have any effect; the "FULL RICH" position on the control quadrant does not work. On all mixture control quadrants, however, the "FULL RICH" position is safety-wired off from the other three positions. An explanation of the control positions, and their effects, follows:

**Automatic Rich**—The usual operating position for mixture control, "AUTO-RICH" maintains the necessary fuel-air ratio for all flight conditions. At high power, the proportion of fuel to air is relatively high, to suppress detonation and assist in cooling. Between normal rated and cruising powers the proportion of fuel is decreased, so that in the cruising range fuel consumption is reduced to the minimum required to prevent detonation and over-heating and to provide good acceleration.

**Automatic Lean**—"AUTO-LEAN" is an alternate operating position of the mixture control, resulting in leaner fuel-air ratios than automatic rich. During the favorable conditions of stabilized level flight or a cruising descent, automatic lean may be used in the cruising power range when fuel economy is of primary importance and when cooling is adequate. Don't try to use intermediate settings beyond the "AUTO-LEAN" position. You gain nothing by any such attempt at manual leaning of the mixture.

**Full Rich**—"FULL RICH" setting of the mixture control renders inactive the altitude compensating device built into the carburetor to compensate for changes in the density of the air flowing through the venturis and keep the

## RESTRICTED

fuel-air ratio constant. "FULL RICH," in reality, is merely a manually enriched mixture, and should only be used when the automatic mixture control unit gives evidence of faulty operation. Despite its other name of "EMERGENCY RICH," "FULL RICH" actually results in a loss of power whenever it is used. Torquemeter tests show, for example, that at 8500 feet, with 35" manifold pressure, 2500 rpm, and "AUTO-RICH," an engine develops 935 Hp. With the same settings and "FULL RICH," the engine develops only 775 HP—a loss of 160 Hp.

**Idle Cut-Off**—Moving the mixture control past automatic lean to the end of its travel will stop all fuel flow, regardless of fuel pressure. "IDLE CUT-OFF" is intended for stopping the engine without the hazard of backfiring.

Mixture strength is increased when operating below the cruising power range. This enrichment provides easier starting and the dependable acceleration needed in taxiing and the approach for a landing. Fuel metering in this power range is accomplished largely by throttle opening.

The accelerating pump is operated by, and in proportion to, the momentary changes in air pressure in the manifold entrance. The accelerating pump is not connected with the throttle or throttle controls. Hence, when the engine is not running, no fuel is pumped from the carburetor when the throttle is moved, no matter how rapidly. You can not prime by pumping the throttle.

### Carburetor Icing

This is the most talked of and least understood type of icing. It is generally agreed that there is no such thing as a non-icing carburetor. However, carburetor ice and the remedies for it differ with each type of aircraft because of the difference in carburetors. Induction-system ice can occur in the B-24. It is more likely to be refrigerated ice than atmospheric ice.

Atmospheric ice can build up on any surface directly in the path of the intake air, such as the intercooler, carburetor butterfly valve, or the angle of the carburetor adapter (usually in the order named).



When air is pouring through the induction system, sufficient temperature drop may cause precipitation of moisture. If the temperature is low enough in the system, the moisture will freeze and adhere to the closest surface. Formation of this ice anywhere in the induction system can block off the flow of air to the engine and can cause almost instantaneous engine failure.

Carburetor ice in the B-24 can occur during otherwise ideal flying conditions. It can occur when it is snowing or sleeting. It can occur any time carburetor air temperature is within the icing range. Watch your carburetor air temperature when relative humidity is high.

Know your induction system and what happens to the air pouring through it. Within 3 hours' time your induction system will use air weighing as much as the airplane.

**Detection of Carburetor Ice**—Icing can progress almost to the point of engine failure before it is indicated on your instruments unless you are alert.

1. Know your carburetor air temperature. If it drops down to 15°C when humidity is high



+ HIGH HUMIDITY = ICING

take measures to bring it back up. Safe range is 15° to 35°C. Above 35°C there is danger of detonation.

2. Note any drop in manifold pressure. A low carburetor air temperature, together with a drop in manifold pressure, suggests carburetor icing. (Do not mistake a drop in manifold pressure caused by change in altitude for carburetor ice.)

3. If you have low carburetor air temperature, plus a sudden drop in manifold pressure, plus a rough-running engine—then, brother, you probably already **have** carburetor ice.

#### **Preventive Measures**

If you are flying at cruising power in conditions where there is danger of carburetor icing, close the intercooler shutters and operate as close to full throttle as possible. If ice has already formed (its formation will be indicated by reduced manifold pressure), open the throttles and increase engine power settings until manifold pressure returns to normal.

**Caution:** Check cylinder-head temperature gages frequently whenever you are operating with the intercooler shutters closed. Excessive cylinder-head temperatures cause detonation.

#### **Function of Intercooler Shutters**

When the turbo compresses air, it generates

heat in the air. This air is going to the carburetor and would normally be too hot, so it passes through the intercooler. When intercooler shutters are open, cool air, taken in through the air duct in the engine cowl, cools the hot air pouring through the intercoolers. When you close the shutters, the intercooler has no cooling effect so that the blast of hot air from superchargers goes uncooled to the carburetor, melts ice and very rapidly builds up the carburetor air temperature. If this goes too high, you get detonation and engine failure. Closing your intercooler shutters, obviously, will not raise your carburetor air temperature unless turbos are operating.

**No Carburetor Air Temperature Gage:** If your plane is not equipped with carburetor air temperature gages, you are short the most important instruments for detecting carburetor ice and for observing the effects of intercooler shutters. It becomes even more vital that you know relative humidity of the air through which you are flying. Avoid closing intercooler shutters unless you **know** there is danger of carburetor ice and then close them intermittently for only a few seconds at a time. Leave them open the instant you note a rise in cylinder-head temperatures or a recovery of manifold pressure.

RESTRICTED

## POWER SETTINGS

### Grade 91 Fuel—Specification ANF-26

OPERATION	SETTING	MIXTURES	RPM	MP	TIME LIMIT	BMEP	HP
Takeoff	Max.	Auto-rich	2700	42"	5 Minutes	169	1060
Climb	Max.	Auto-rich	2550	38"	1 Hour	160	950
Climb	Desired	Auto-rich	2550	35"	Continuous	147	870
Cruise		Auto-lean	1650-2100*	30"	Continuous	—	—
Local Cruise	Suggested	Auto-lean	2000	30"	Continuous	131	610

\*Maximum and minimum rpm in Auto-lean. Do not exceed 30" manifold pressure.

### Grade 100 Fuel—Specification ANF-28

OPERATION	SETTING	MIXTURES	RPM	MP	TIME LIMIT	BMEP	HP
Takeoff	Max.	Auto-rich	2700	49"	5 Minutes	192	1200
Climb (Normal Rated Power)	Max.	Auto-rich	2550	46"	Continuous*	186	1100
Climb	Desired	Auto-rich	2550	41"	Continuous	167	990
Cruise	Max.	Auto-rich	2325	35"	Continuous	152	820
Cruise	Max.	Auto-lean	2200	32"	Continuous	140	715
Cruise	Desired	Auto-lean	2000	30"	Continuous	131	610

\*Cyl. head temp. not to exceed 232°C. For temperatures of 232° to 260°, time limit is 1 hour.

## DEFINITIONS OF RATINGS

**Takeoff Rating:** This is the maximum power and engine speed permissible for takeoff and should be maintained only long enough to clear obstructions.

**Military Power:** This is the maximum power permitted for the military services with less regard for long life of the engine than for immediate tactical needs. Military rating is comparable to takeoff power with manifold pressures modified to suit altitude conditions, and may be used for 5 minutes in any attitude of flight.

**Normal Rated Power:** This is frequently referred to as a normal maximum rating, or maximum except takeoff power. It is the maximum power at which an engine may be operated continuously for emergency or high performance operation in climb or level flight if cylinder-

head temperatures do not exceed 232°C.

**Maximum Power and RPM for Cruising:** This rating stipulates both the maximum power and maximum rpm permissible for continuous operation with the mixture control in automatic lean. The proper combination of rpm and manifold pressure for the particular horsepower, load and altitude desired can be determined from the cruising control charts.

In takeoff emergencies, you can get 1350 Hp from your engines by using auto-rich, 2700 rpm, and 56" manifold pressure. These settings give you a BMEP (brake mean effective pressure) of 216. Use this emergency power only if you have to, and then only for the shortest possible time—never more than 5 minutes. Don't go into full (emergency) rich; you sacrifice power if you do.

# SEQUENCE OF POWER CHANGES

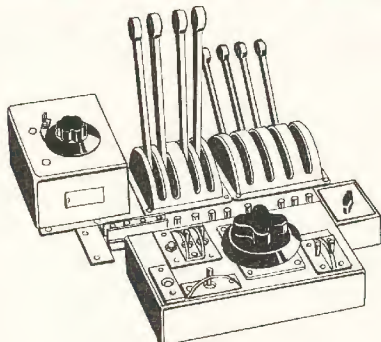

There are ironclad rules regarding the sequence for increasing or reducing power. Failure to follow the sequence can cause premature firing, excessive pressures, overheating, detonation, and engine failure. Three inter-related elements are involved in any power change, namely: mixture, manifold pressure, and rpm.

**Relationship of Mixture and Manifold Pressure**  
 "AUTO-LEAN," for example, automatically reduces the proportion of fuel to air to provide efficient firing with minimum expenditure of fuel. However, as manifold pressure is increased (increasing the pressure in the cylinders), there is a point beyond which the excess pressure will cause hot, hard, and fast firing, with detonation and overheating. If the fuel-air ratio is richer, the same manifold pressure will produce slower, stronger firing, with less heat. That's why richer mixtures must be used at higher power settings.

On the other hand, too rich a mixture interferes with the proper expansion and firing of the gases and results in overloading, torching, and loss of power.

### Relationship of Manifold Pressure and RPM

The constant-speed propeller does exactly what its name implies. The propeller governors function so that if propellers are set for a given rpm, governors automatically change the pitch of the propellers to keep them turning at the given rpm. Thus, if a propeller governor is set for 1900 rpm and manifold pressure is increased, the governors increase the pitch of propellers so they take a larger bite and continue to turn at 1900 rpm; this puts a larger load on the power plant and builds up pressure in the cylinders. This is permissible within specified limits, but as pressure increases heat increases. An increase in the speed of propellers gives an outlet for the extra power being produced.

### Brake Mean Effective Pressure

The brake mean effective pressure (BMEP) is the average pressure within the cylinder of an engine during the power stroke of the piston. As the pressure within the cylinder is increased, more heat is developed because of the energy of compression. If the pressure and temperature increase sufficiently, detonation occurs.

The formula for determining BMEP for 1830-43 or 65 P & W engines is:

$$\text{BMEP} = \frac{433 \times \text{BHP}}{\text{RPM}}$$

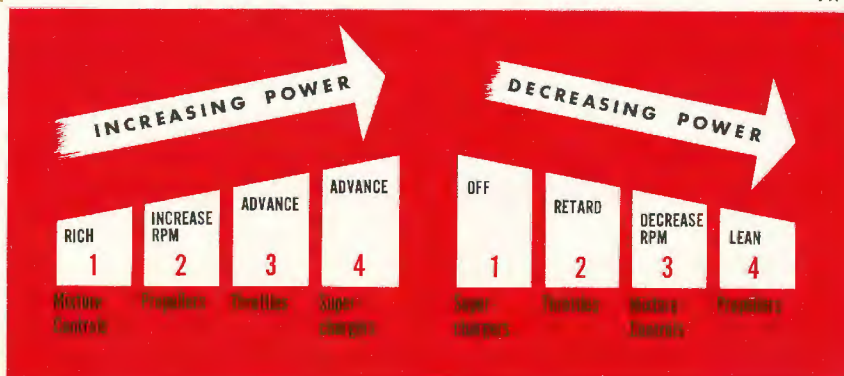

## STEPS FOR INCREASING POWER

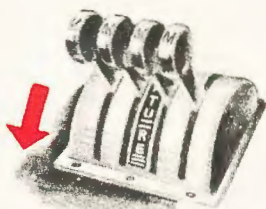

### 1. Mixture Controls.

Copilot sets the mixture controls to "AUTO-RICH" (if necessary) at pilot's signal. Reason: Maximum setting in "AUTO-LEAN" is 32" manifold pressure and 2200 rpm with Grade 100 fuel, and 30" and 2100 rpm with Grade 91 fuel. It is obvious that if power is to be increased beyond these maximums the mixture should first be set in "AUTO-RICH."



### 2. Propellers.

Copilot increases rpm to desired setting. This should precede the manifold pressure increase to eliminate the danger of an excessive BMEP (brake mean effective pressure) and resultant detonation.

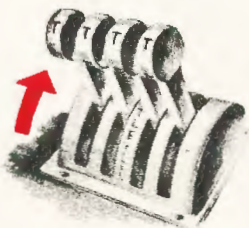

### 3. Throttles.

Pilot advances throttles as the rpm is increased. If more power than full throttle is required, superchargers are advanced.



### 4. Superchargers

With electronic control, advance the TBS knob. With oil regulator, the supercharger controls may all be advanced together, but it is advisable to set them one at a time, starting with the dead-engine side if operating with a dead engine. Always use full throttle before applying supercharger boost. Reason: A partially closed throttle will create a back pressure in the induction system resisting turbo pressure. This causes a rise in carburetor air temperature with possible power loss and detonation.



## STEPS FOR REDUCING POWER

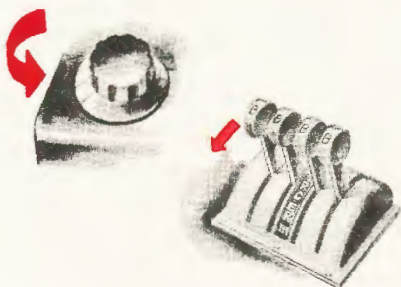

### 1. Superchargers

To reduce power, pilot first slowly retards supercharger controls—TBS or levers: slowly in order to prevent cracking of the turbo nozzle box by too rapid cooling, superchargers before throttles to prevent back pressure in induction system.



### 2. Throttles.

Pilot retards throttles before reducing rpm. Reason: Manifold pressures must be reduced

before propellers in order to keep BMEP on the low side of safe limits and to prevent detonation.



### 3. Propellers.

Copilot decreases rpm at command of pilot. This must follow throttles. A sufficiently low rpm permits mixtures to be brought to "AUTO-LEAN."

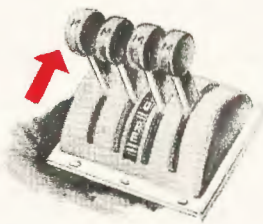

### 4. Mixture Controls.

Copilot puts mixture controls in "AUTO-LEAN" if new power setting falls within limits of manifold pressure, rpm and cylinder-head temperatures. Wait until engines are cool before going into "AUTO-LEAN," because a hot engine increases the tendency to detonate.

## CAUSES OF ENGINE FAILURE

In considering engine failures, always remember there are three things that make an engine run—fuel, oil, and ignition. Failure of any of these three systems, plus structural failure, are the only things which can cause the loss of an engine.

Structural failure can be mechanical—the result of faulty construction or maintenance—but most of the time it is induced. Accident analyses show that pilot error far outruns mechanical failure in bringing about engine troubles. Here are a few examples of stupid pilot errors which induce engine failure; avoid them.

1. **Failure to Know Gas Consumption.** Example: A pilot flew 5½ hours on a practice bombing mission in "AUTO-RICH" at a high power setting. Airplane crashed and 5 men lost their lives.

2. **Failure to Reduce Manifold Pressure at High Altitude.** This can result in an overspeeding turbo wheel disintegrating. One of the buckets coming your way is just like a .50-cal. bullet.

3. **Failure to Turn Booster Pumps On at High Altitudes.**

4. **Increasing Power Without Changing Propeller Setting.**

5. **Increasing Manifold Pressure Before RPM Instead of After.**

6. **Failure to Use Auto-Rich in Power Settings Above Normal Cruise.**

7. **Stiff-Arming Throttles.**

8. **Failure to Observe Engine Instruments and to Control Excessive Temperatures.**

9. **Failure to Know the Fuel System for Particular Airplane You Are Flying.**

10. **Waiting Too Long to Transfer Fuel.**

11. **Taking Off in Auto-Lean.**

12. **Failure to Turn On Booster Pumps for Takeoff, Causing Collapse of Fuel Lines or Vapor Lock.**

13. **Failure to Observe Carburetor and Free Air Temperature Under Icing Conditions.**

14. **Waiting Until Too Late to Correct for Carburetor Ice.**

15. **Improper Use of Intercooler Shutters Resulting in Excessive Carburetor Heat and Detonation.** Example: One pilot, at high altitude, thought he had an icing condition but failed to observe normal carburetor air temperature. He closed the intercooler shutters, producing high carburetor air and cylinder-head temperatures, followed by the failure of 3 engines. Never let carburetor air temperature get above 35°C, especially when using Grade 91 fuel.

16. **Failure to Have Fuel Valve Selectors on Tank-to-Engine for Take-off and Climb.** One pilot took off with all fuel valves on crossfeed with bomb bay transfer pump on, using gas from bomb bay tanks only. After takeoff, copilot turned off the bomb bay transfer pump switch, which is located on his instrument panel, thinking it was a booster pump. Immediately 4 engines failed and the ship crashed.

17. **Improper Procedure With Overspeeding Turbo on Takeoff.** Example: Pilot took off and experienced an overspeeding turbo, running manifold pressure beyond gage limits. He failed to reduce power and bring the turbo under control. The engine blew 5 cylinders and froze in high rpm. He managed to land, but unnecessarily destroyed an engine.

18. **Immediate Feathering of a Runaway Propeller When the Propeller Could Have Been Brought Under Control With Proper Procedure.** Example: Pilot, during takeoff with a combat load, experienced a runaway propeller. Without trying to bring the propeller under control he feathered immediately. He was unable to maintain altitude and the ship crashed shortly after takeoff. Proper procedure would have given 15 to 50% power on that engine.

## DETONATION

Improper firing may be caused by a hot spot within the cylinder, an overheated sparkplug, exhaust valve, carbon deposit, etc. Once this gets started, it becomes progressively worse. The timing of the engines becomes uncontrolled

and roughness, and/or detonation, results. The engine becomes overheated and loses power.

Some of the factors over which you have control, and which increase the tendency of the engine to detonate, are: High manifold pressure with low engine speed; too lean a mixture; high inlet temperatures; high cylinder-head temperatures; and improper low-grade fuel.

Under normal conditions, the fuel charge in a cylinder burns quite slowly. When detonation occurs the first part of the charge within the cylinder burns rapidly. This compresses the unburned part of the charge until the pressure and temperature within the cylinder rise so

high that the unburned portion of the charge is ignited spontaneously, or detonated.

The pressure of the unburned charge fluctuates at a high frequency. These fluctuations literally hammer the wall of the cylinder and cause the familiar knock.

Even mild detonation will cause overheating, valve, piston, and cylinder-head burning, piston scuffing, and piston ring and valve damage. Severe detonation will cause engine failure in a short time. Complete engine failure can occur because of detonation during the time it takes you to make a takeoff run. The indications of detonation are roughness and overheating.

## SOME EXAMPLES OF FAULTY OPERATION

Fault	Flight Reaction	RPM	Manifold Pressure	Cyl. Head Temp.	Oil Temp.	Oil Pressure	Fuel Pressure	Carburetor Air Temps.
Broken Fuel Line	Yaw	*—	Drop if Turbo on	Rapid Drop	Drop	—	Zero	—
Broken Oil Line	—	—	—	Rise	Rise	Drop to Zero	—	—
Breakage of Moving Engine Parts	Possible Violent Vibration	Violent Fluctuation	Unpredictable	Unpredictable	Rise	Variable	Variable	—
Ignition Trouble	Rough Running Engine and Intermittent Yaw	Fluctuation	Fluctuation if Turbo on	Drop	—	—	—	—
Overheating from Closed Intercoolers	—	—	Probable Drop	Rapid Rise	Rise	—	—	Rise
Mixture Too Rich	Torching Turbo or Black Smoke	—	—	Slight Drop	—	—	—	Slight Drop
Failure of Auto-Mixture Feature	Rough Running Engine	Fluctuation	—	Rise or Drop	Rise or Drop	—	—	Rise or Drop
Overspeeding Turbo	—	Possible Overspeeding	Violent Rise	Rapid Rise	Rise	—	—	Rise
Runaway Propeller	Possible Vibration	Rapid Increase	Drop	Variable	Variable	—	—	—
Carburetor Ice	Rough Running Engine	Fluctuation	Drop	—	—	—	—	Drop
Restricted Fuel Flow	Slight Yaw	—	Drop if Turbo on	Drop	—	—	Fluctuation	—

\*Sign — (Dash) indicates no apparent change.

RESTRICTED

# EQUIPMENT AND SYSTEMS

## *Systems Described in This Section*

**HYDRAULIC SYSTEM**

**ELECTRICAL SYSTEM**

**OIL SYSTEM**

**FUEL SYSTEM**

**HEATING SYSTEM**

**ANTI-ICERS, DE-ICERS AND DEFROSTERS**

**OXYGEN SYSTEM**

**VENTILATING SYSTEM**

**AUTOMATIC PILOT, PDI AND FORMATION STICK**

**GYRO FLUX GATE COMPASS**

**RADIO EQUIPMENT**

Know your airplane! That's the only way you can qualify yourself to fly it with maximum effectiveness. Which instruments are autosyn? Where are the fuse boxes? How do you transfer fuel in your particular airplane? What is the layout of the oil system? This is just a start on the questions every pilot will want to be able to answer in detail to be prepared to meet emergencies that can jeopardize his airplane and his crew.

Here's what a B-24 combat pilot says:

"What you know about the airplane will determine whether you can bring one back that is badly shot up. If we had it to do all over, we would dig in twice as hard to know that airplane from one end to the other. You may be able to get by the minor things, such as engine trouble, but when you run into damage

to systems from AA and fighter fire, you must know a lot about the airplane to fly it home."

The following sections give brief, basic information about the airplane. Don't be satisfied with what you learn here. Query your instructor, your engineer, read the P.I.F., dig into technical orders and study the airplane from nose to tail repeatedly.



# HYDRAULIC SYSTEMS

The principle of hydraulic power is the actuating of a piston within a cylinder, usually double acting. Pressure may be applied to either side of the piston for power in either direction, by means of hydraulic pressure supplied by a power pump. Oils and liquids are not compressible; therefore, the power delivery of any hydraulic system is directly proportional to the applied pressure.

## Hydraulic Equipment in the B-24

1. The main hydraulic system operates the tricycle landing gear (including retractable tailskid), wing flaps, bomb bay doors, power brake, Sperry automatic pilot (when supplied), and the nose turret.
2. The hydraulic shock absorber units cushion the landing impact and taxiing loads on the tricycle landing gear.
3. The hydraulic nosewheel shimmy damper unit dampens the tendency of the nosewheel to shimmy from side to side.
4. The hydraulic tail and nose turret units control the rotation of the turrets, the elevation of the guns, and the charging mechanisms.

## Main Hydraulic System

The hydraulic system consists of a main open center system and a secondary accumulator system. It uses hydraulic fluid of specification AN-VV-O-366a. The capacity of the entire system is approximately 18 U.S. gallons, while the reservoir capacity is 3.8 gallons from bottom of reservoir to center suction outlet, plus 3 gallons from center suction outlet to filler neck.

1. In the open center system the fluid circulates freely in a completely closed circuit when no hydraulic mechanisms other than the engine-driven pump are operating. The open cen-

## RESTRICTED

ter system operates the bomb bay doors, wing flaps and landing gear.

2. In the accumulator system fluid is under constant high pressure built up in two accumulators. This system is the sole source of pressure for operation of brakes, nose turret, Sperry

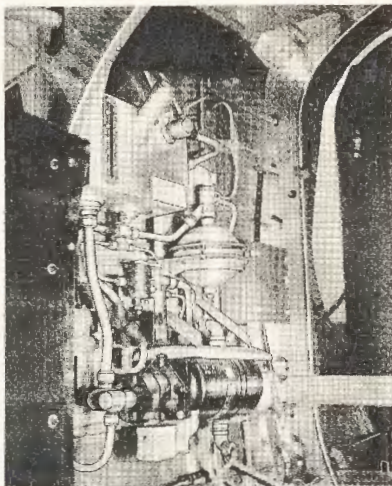

TAIL TURRET HYDRAULIC SYSTEM

automatic pilot (when provided), and auxiliary and emergency (hydraulic) control of bomb bay doors.

## Hydraulic Pumps

### 1. Engine-Driven Hydraulic Pump

The main, or Vickers positive displacement, pump (19), driven by No. 3 engine, supplies pressure for the main system. The pump normally floats on the line. When the flow is diverted by closing any selector valve to operate an hydraulic mechanism, pressure builds up to an amount required to operate the mechanism.

The pump's secondary function is to maintain pressure in the accumulator system. An automatic unloading valve (9) in the engine-

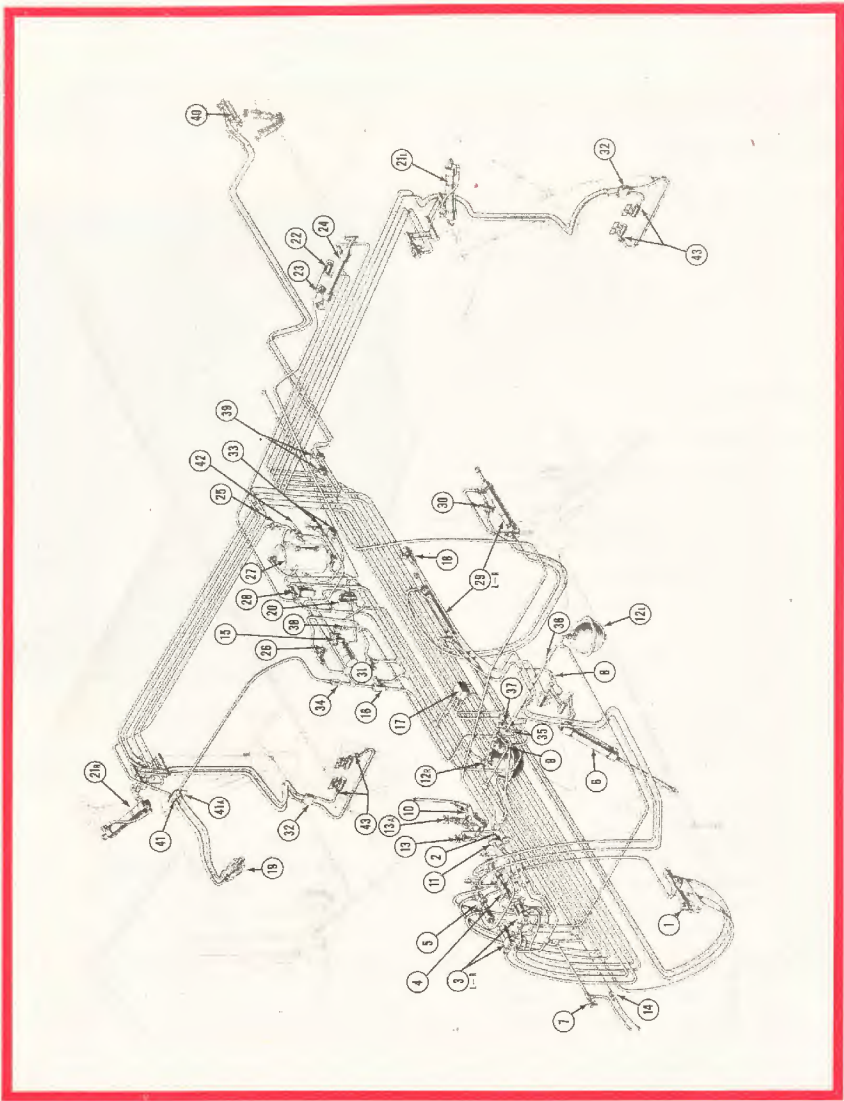

# MASTER KEY LIST OF HYDRAULIC UNITS FOR HYDRAULIC SYSTEM DIAGRAMS

---

- 
1. Bomb Bay Door Selector Valve
  2. Brake Pressure Gages
  3. (L & R) Brake Control Valves
  4. Landing Gear Selector Valve
  5. Flap Selector Valve
  6. Nosewheel Actuating Cylinder
  7. Nose Turret Shut-Off Valve
  8. Nosewheel Restrictor
  9. Unloading Valve
  10. Hand Pump
  11. Hydraulic System Pressure Gage
  12. (L & R) Accumulators
  13. Hand Pump System Valve
  - 13A Hand Pump Flap Valve
  14. Nose Turret Check Valve
  15. Auxiliary Electric Pump
  16. Relief Valve
  17. Bomb Door Emergency and Utility Control Valve
  18. Main Landing Gear Restrictor
  19. Engine Driven Pump
  20. Pressure Switch
  21. (L & R) Main Landing Gear Actuating Cylinder
  22. Relief Valve
  23. Shuttle Valve
  24. Flap Actuating Cylinder
  25. Suction Line Check Valve
  26. Auxiliary Star Valve
  27. Fluid Reservoir
  28. Filter
  29. (L & R) Bomb Bay Doors Actuating Cylinder
  30. Bomb Door Cylinder Relief Valve
  31. Auxiliary System Relief Valve
  32. (L & R) Brake Bleeder Valve
  33. Test Stand Connections
  34. Check Valve
  35. Check Valve
  36. Left Accumulator Check Valve (Spring Removed)
  37. Right Accumulator Check Valve
  38. Auxiliary Pump Check Valve
  39. Tail Bumper Shut-Off Valves
  40. Tail Bumper Actuating Cylinder
  41. Automatic Seal Coupling
  - 41A Automatic Seal Coupling
  42. Emergency Suction Valve
  43. Brake Disconnect Coupling
-

## RESTRICTED

driven pump pressure line regulates this operation. When the accumulators are charging, all the fluid flow in the open center line is diverted by the unloading valve to the accumulators.

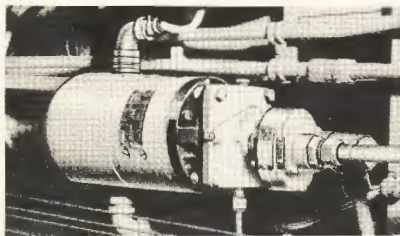

### 2. Auxiliary Hydraulic Pump

An electrically driven gear-type pump (15), located on the right side of the fuselage in the forward bomb bay, maintains accumulator pressure when the engine driven pump is not operating. An automatic pressure switch (20) and a manual master switch control the pump motor.

When the engine-driven pump fails, an emergency hydraulic (star) valve (26) just above and forward of the auxiliary hydraulic pump may be turned on to connect the pump into the main system.

The auxiliary hydraulic pump receives power from the right hand power bus—normal load 95 to 98 amperes—and has 2 functions:

a. Accumulator charging function—The auxiliary hydraulic pump is turned on before taxiing and off before takeoff, and turned on again just before landing. When turned on (emergency hydraulic star valve (26) closed) this pump maintains the pressure in both accumulators (12L) and (12R) between the limits 975 lb. sq. in. and 1180 lb. sq. in. while the engine pump supplies fluid only to the open center system selector valves. This is made possible by the relative pressure adjustments of unloading valve (9) and pressure switch (20).

b. Emergency function—In the event of failure of engine-driven pump (19) or engine No. 3 to which it is attached, the auxiliary hydraulic pump is turned on and interconnected to the

open center pressure line by opening emergency hydraulic (star) valve (26). Then the auxiliary hydraulic pump performs exactly the functions of the engine driven pump.

### 3. Hydraulic Hand Pump

The hydraulic hand pump (10) is located outboard of the copilot's seat. This pump delivers pressure to the line and can be used for operation of the entire hydraulic system by pumping fluid into the open center line through forward valve (13) on hand pump; or it can be used independently for lowering of the wing flaps by pumping fluid through aft valve (13A) to the flap cylinder.

Fluid for the hand pump (10), which is not part of the open center system, is drawn from the bottom of the reservoir through a separate line. The hand pump is used only for emergency operation.

**Reserve Fluid**—In the event of low fluid level in the reservoir (27) the engine-driven pump and the electrically driven pump may be connected to the bottom of the reservoir by closing the suction valve (42) provided in the reservoir outlet. This should be done only after steps have been taken to insure that no further loss of fluid can take place, or the reserve supply will be wasted through the same outlet.

**Caution:** The landing gear, bomb bay doors, and flaps retracting mechanisms cannot be operated simultaneously.



### Operating Pressures

The main system pressure gage on the instrument panel should indicate approximately 50 lb. with no controls operating. With any system being used, this pressure should rise to between 100 and 1100 lb.

The wing flaps should be operated before flight to allow the pilot to check the system and the operating pressures built up at the gage. The brake pressure gage should always show a pressure of approximately 850 to 1180 lb. sq. in.



### PRESSURE SETTINGS

Engine pump relief valve . . . . .	1250 lb. sq. in.
Auxiliary electric pump relief valve . . . . .	1250 lb. sq. in.
Bomb doors open relief valve . . . . .	750 lb. sq. in.
Wing flaps down relief valve . . . . .	500 lb. sq. in.
Auxiliary pump pressure switch . . . . .	975-1180 lb. sq. in.
Accumulator unloading valve . . . . .	850-1050 lb. sq. in.

### SELECTOR VALVE RELIEF

Landing gear . . . . . Up	1100 lb. sq. in.	Down	850 lb. sq. in.
Wing flaps . . . . . Up	750 lb. sq. in.	Down	450 lb. sq. in.
Bomb bay doors . . . . . Open	600 lb. sq. in.	Close	1000 lb. sq. in.

### LANDING GEAR AND TAIL BUMPER HYDRAULIC CONTROL

The landing gear (2 main wheels, nosewheel) and the tail bumper gear are operated simultaneously under hydraulic control. The main control (4) for extending and retracting the gear is located on the left side of the pilot's pedestal. Movement of the operating lever is restrained by an electric solenoid, which is controlled by 2 switches in series. The operating switch is a push button in the operating handle itself; the other, a safety switch, is located on the left landing gear fairing. Extension of the landing gear strut on takeoff closes the safety switch and allows the circuit to be completed by pressing the operating switch button on the valve operating lever. The locking solenoid is located back of the instrument panel, and restrains the lever from "UP" position only.

Movement of selector valve (4) to the "UP" position applies hydraulic pressure simultaneously to the side gear restrictor (18) and to the nosewheel actuating cylinder (6). The side gear restrictor restricts the flow of fluid to the main landing gear until the pressure reaches 800 lb. sq. in. This pressure is sufficient to house the

nose gear. When pressure exceeds 800 lb. sq. in. the restrictor opens and allows fluid to go to the side gear cylinders.

On the lowering operation, pressure is applied to all 3 gear cylinders simultaneously. In case of insufficient pressure in the hydraulic system, the hand pump may be used.

In case of complete failure of the hydraulic system, the tricycle landing gear may be lowered manually. No means of manual control is provided for the tail bumper.

#### Main Landing Gear

Each main landing gear mechanism, operated by the main retracting cylinders through over-rides, is equipped with 2 latches.

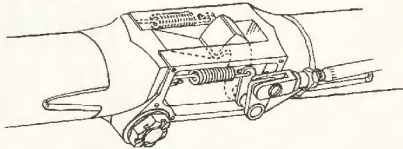

Down-Latch on Drag Strut Knuckle

When the main gear is fully extended, a spring-loaded latch on the side brace knee holds the side brace rigid and locks the gear in place.

## RESTRICTED

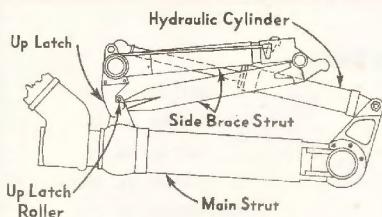

Another latch, on the side brace pivot in the wing, locks the gear in the retracted position.

The main gear down-latch is painted yellow and can be seen for down-latch check from the side window. It cannot be seen if flaps are lowered.

### Nosewheel Gear

The nosewheel retracts into the nose of the fuselage under the pilot's floor. The nosewheel doors are mechanically connected to the gear mechanism so that they open automatically before the gear is extended and close after the gear is retracted.

The nosewheel is designed to turn 45° either side of the center line for free ground maneuverability but should never be turned more

than 30°. A hydraulic shimmy damper tends to restrain any oscillation of the gear about its vertical axis. An internal centering cam in the oleo returns the wheel to its straight-ahead position when the oleo is fully extended. A single latch on the drag link, actuated by the hydraulic jack over-ride, locks the nosewheel gear in both the retracted and extended positions.

### Tailskid and Tail Bumper Gear

A retractable tailskid and bumper is installed on aircraft beginning with Serial No. 41-23640. It may be used within certain limits on tail-low landings. Do not land skid first.

The tail bumper protects the bottom of the fuselage in case the airplane should accidentally tilt back.

### Warning Signal Light

A green light on pilot's instrument panel is lighted whenever the landing gear is down and locked.

Further warning that the gear has not been extended is given by an electric horn (on some aircraft) connected to the throttle controls. When the throttles are moved backward to approximately  $\frac{3}{4}$  closed, and all landing wheels are not extended and locked, the horn will blow

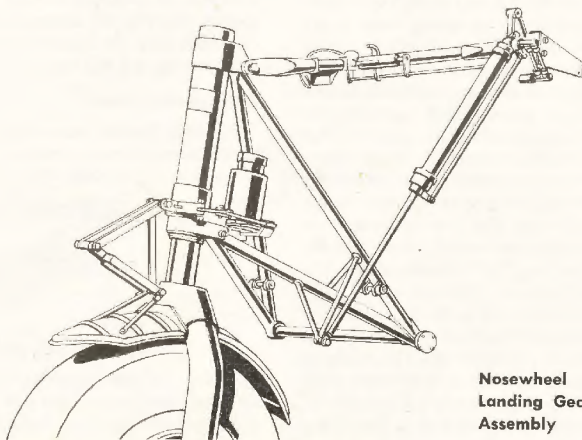

Nosewheel  
Landing Gear  
Assembly

until the gear has been extended and locked or until the throttles are opened to higher engine speed. The horn may be silenced by pressing the pilot's interruption switch on the pilot's pedestal. The horn will then remain silent until the throttles are moved again. This re-sets the horn relay so that another closing of the throttles would again actuate the horn. The horn interruption switch is provided in the event it is necessary to continue flight with one or more engines throttled.

The green light is wired through switches on all 3 landing gear units. On aircraft equipped with bottom turrets, this warning is also given when the turret has not been fully retracted and when the guns have not been completely housed.

**Note:** On recent aircraft, there is a push-to-test button for the warning light. This button tests only the operation of the light itself; it is not a check on whether the gear is down and locked. The green light should go on when you push the button, even if the gear is up. If it doesn't go on, the bulb may be burned out. If you lower the gear and the light does not indicate down and locked, don't assume that the gear is down and locked if the light goes on when you push the test button.

## WING FLAP HYDRAULIC CONTROL

### General

The Fowler-type wing flaps are operated by a single hydraulic jack (24) which lies along the left rear wing spar at Wing Station 3.0. The flaps move along tracks in the trailing edge and

are extended and retracted by a lever on the right side of the pilot's pedestal. To raise flaps, move lever forward; to lower flaps, pull lever aft.

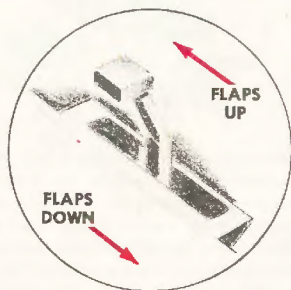

With full flaps extended, speeds in excess of 155 mph will create a sufficient pressure on the flaps to open a relief valve (22) at the operating cylinder and allow the flaps to retract automatically.

**Caution:** This relief valve is a safety precaution only. Do not test during flight as the excessive pressures required for this operation might damage the mechanism.

In case of partial failure of the main hydraulic system, the hand pump (10) outboard of the copilot's seat may be used through an independent direct line to the flap cylinder to extend only.

In case of complete failure of the hydraulic system, no manually controlled system is provided for the wing flaps.

## BOMB BAY DOORS HYDRAULIC CONTROL

Two individual hydraulic jacks, one on each side of the fuselage, operate the bomb bay doors.

The operation of the bomb bay doors is controlled from any one of 4 positions:

1. Bombardier's compartment
2. Under radio operator's floor at hatch opening
3. On the ground from access door on right side forward of bomb bay door
4. Pilot's compartment

Main control valve  
Auxiliary control valve

Auxiliary control valve

Emergency operation of auxiliary valve. Doors may be opened but not closed until pull line is re-set

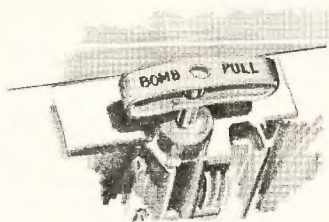

**CAUTION:** The pilot's emergency pull line to the auxiliary valve cam (see No. 4 control) must be re-set by hand or hydraulic system will bypass through the bomb jack relief valve, thus affecting the entire hydraulic system.

Under military operating conditions the main control valve is used to control the operation of the doors.

The auxiliary valve, in the accumulator system, is generally used for local flight operations.

In case of complete failure of the hydraulic system, the doors may be operated manually by hand cranks accessible from the catwalk at the center of the bomb bay.

#### Bomb Bay Door Position Indicators

When these doors are fully open the following lights are illuminated:

1. A red light on the bombardier's panel.
2. An amber light on the pilot's panel.
3. A white light on the tail to notify other airplanes in the formation.

#### POWER BRAKE HYDRAULIC CONTROL

Two completely separate units operate the hydraulic brakes. Each unit contains 2 brake cylinders which control one of the dual Hayes expanding-bladder-type brakes on each main landing wheel. One cylinder of each unit is mechanically interconnected to the right brake pedal of both pilot and copilot; the other cylinder of each unit is similarly connected to both left brake pedals.

Each unit takes its pressure directly from a different one of the 2 main accumulators which are isolated from each other by check valves so that failure of one accumulator does not affect the other. Failure of one complete unit leaves  $\frac{1}{2}$  braking power available.

#### NOSEWHEEL HYDRAULIC SHIMMY DAMPER

In landing or takeoff the nosewheel has a tendency to shimmy. A shimmy damper installed on the oleo strut dampens out this vibration without restricting any of the normal functions of the nosewheel. Two types of shimmy dampers are installed on B-24 aircraft. One type utilizes 2 hydraulic cylinders which act in opposite directions and are connected to an accumulator. Vibration is absorbed by the combined action of fluid passing through a restricted orifice and by the compressed air in the accumulator.

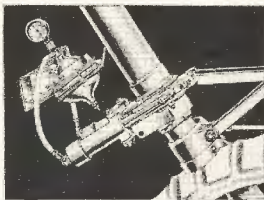

Accumulator Type Damper

The other type of shimmy damper is a single self-contained unit which dampens vibration by causing hydraulic fluid to flow through restricted orifices.

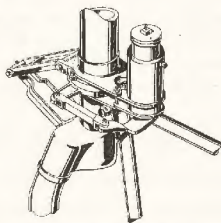

Houdaille Type Damper

In case of failure of the early accumulator type of shimmy damper, provision was made for locking it in a straight-travel, non-steerable position. This procedure was covered by an instruction chart at Station 1.2 on the right of the fuselage. No locking procedure is provided for the later type of Houdaille shimmy damper.

# ELECTRICAL SYSTEM

## Power Supply

1. When the engines are operating, power is generated by four 24-volt, 200-ampere, type P-1 generators, one on each engine. The voltage of each generator may be adjusted at the voltage regulator under the flight deck on each side of the centerline.

2. Main battery power is supplied by two 24-volt, 34-ampere-hour batteries connected in parallel.

3. Auxiliary power is supplied by a type C-10 auxiliary generator, with a capacity of 2.0 kilowatts and powered by an independent gasoline engine (Homelite unit). This auxiliary generator must be run for starting engines, or in the case of main generator failure in flight. The auxiliary power unit is not supercharged and power generation from the auxiliary unit, therefore, ceases at high altitudes.

4. For ground operation a provision is made for an external (battery cart) connection. Always use battery cart for first starts, where available, or have auxiliary power unit in operation. The excessive loads incident to initial start will shorten the life of the main batteries.

**Note:** The battery switches must be left off when using battery cart.

## Electrical Systems

1. Direct current, 24-volt, single-wire system. Most of the electric equipment in the airplane, including late design of fluorescent lighting, is supplied through this system.

2. Alternating current 26-volt system for the autosyn indicator system.

3. Alternating current 115-volt system for the fluorescent lighting on some airplanes and the radio compass. Two independent inverters controlled by a selector switch on the pilot's pedestal permit use of either unit.

4. Alternating current 3-volt system for compass lighting, on some airplanes.

5. Miscellaneous systems for the gun turrets, automatic flight controls and radio.

## Fuse Boxes and Circuits

From the various fuse boxes to which the above power is delivered, the following 16 DC and AC primary circuits distribute power to the mechanisms those circuits operate:

- Heating and ventilating controls
- Bomb release and signals
- Propeller controls
- Ice elimination controls, fuel and hydraulic pumps
- Exterior lights
- Instruments
- Ignition
- High tension
- Automatic flight controls and turrets
- Interior and recognition lights
- Landing gear signals and flap position indicator
- Power
- Radio and communication
- Engine starter
- Engine controls
- Misc. (camera, alarm bell, etc.)

## Lights

Location and purpose of interior lights is given in the section on night flying.

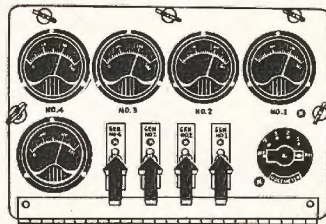

## Panels and Switchboards

Generator control panel is on forward face of bulkhead at Station 4.1, left side of flight deck,

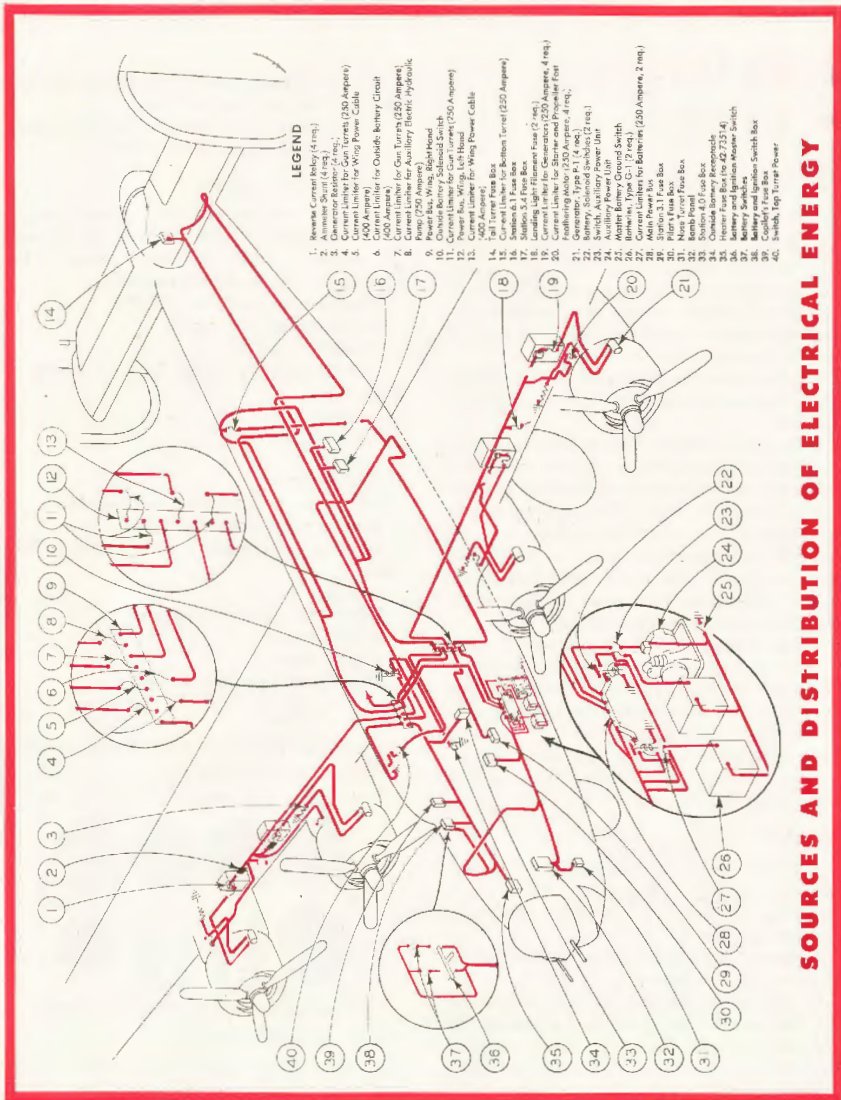

**LEGEND**

1. Reverse Current Relay (4 req.)
2. Generator
3. Generator Regulator (4 req.)
4. Current Limiter for Gun Turret (250 Amperes, 4 req.)
5. Current Limiter for Wing Power Cells (400 Amperes)
6. Current Limiter for Outside Battery Circuit
7. Current Limiter for Gun Turret (250 Amperes)
8. Current Limiter for Auxiliary Electric Hydraulic
9. Power Bus, Wing, Right Hand
10. Chinese Battery Submerged Switch
11. Chinese Battery (150 Amperes)
12. Power Bus, Wing, Left Hand
13. Current Limiter for Wing Power Cells
14. Top Turret Fuse Box
15. Switches for Gun Turret (250 Amperes)
16. Station 3.4 Fuse Box
17. Station 3.4 Fuse Box
18. Station 3.4 Fuse Box
19. Current Limiter for Generator (250 Amperes, 4 req.)
20. Current Limiter for Starboard and Propeller Foot (250 Amperes, 4 req.)
21. Generator, Type B1 (4 req.)
22. Battery, Bi-metall Switches (2 req.)
23. Station 3.4 Fuse Box
24. Auxiliary Power Unit
25. Motor Battery Ground Switch
26. Current Limiter for Batteries (150 Amperes, 2 req.)
27. Main Power Bus
28. Main Power Bus
29. Main Power Bus
30. Pilot's Fuse Box
31. Non-Turret Fuse Box
32. Station 4.0 Fuse Box
33. Station 4.0 Fuse Box
34. Chinese Battery Recovery
35. Battery and Ignition Master Switch
36. Battery Sparkles
37. Station 4.0 Fuse Box
38. Station 4.0 Fuse Box
39. Coach's Fuse Box
40. Switch, Top Turret Power

**SOURCES AND DISTRIBUTION OF ELECTRICAL ENERGY**

and carries 4 field switches to cut generators in or out of main system. One voltmeter with multi-point selector switch indicates voltage output of each generator or main bus, and the 4 ammeters, one for each generator, indicate current flow.

Voltage regulators, 2 on each side forward of bulkhead at Station 4.0 under flight deck, provide generator voltage adjustment for balance of load.

Five main electric switch panels control the distribution of power to the 16 primary circuits. One of these is at the left of the bombardier; the other 4 are in the pilot's compartment.

#### Spare Current Limiters, Fuses and Lamps

The fusible links for the 4 main generators are not accessible in flight; neither are the landing light filament circuit fuses nor the nacelle power circuit limiters in the nacelle junction boxes.

Fuses and interior limiters are replaceable in flight and are located as follows:

1. Spare fusible links are located in the limiter boxes which are located as follows: 2 on left accumulator bracket; 4 on the left and 6 on the right rear face of the bulkhead at Station 4.1. All limiters require a 1/2-inch wrench to remove and install.

2. Spare fuses are provided in each fuse box.

3. A spare bulb for the landing gear down-position indicator is clipped to the instrument panel.

4. A spare bulb assortment is located aft of bulkhead at Station 4.0 on the left side. No spare bulbs for exterior lights are carried.

**Note:** Fuse boxes in general are located near places where fuses are used. Open these boxes and study the chart to see what fuses are provided and where they are used. This will save a hurried hunt in emergencies.

## OIL SYSTEM



Each engine nacelle contains its independent oil system, consisting of a hopper-type self-sealing tank 32.9 U.S. (27.3 Imperial) gallons, temperature regulator, engine pump, and propeller feathering pump.

Engine oil systems provide oil for lubrication of the turbo-supercharger impellers and for operation of the propeller feathering system. The supercharger waste gate regulator, Eclipse type A-13, which is installed on early B-24G, H, and J aircraft, is also actuated by engine oil pressure.

The oil dilution valve for each engine is controlled by a switch located on the copilot's switch panel. Engine oil may be heated by externally powered neck-type immersion heaters.

An oil temperature indicator located on the copilot's instrument panel indicates the oil temperature as determined by a resistance bulb in the Y drain valves.

An oil pressure indicator located on the copilot's instrument panel measures the oil pressure at a restricted fitting in the rear crank case section as determined by an autosyn transmitter.

#### Oil Dilution

Oil dilution is necessary when ground temperatures reach 4°C or lower, in order to keep the oil from congealing so much that starting will be difficult.

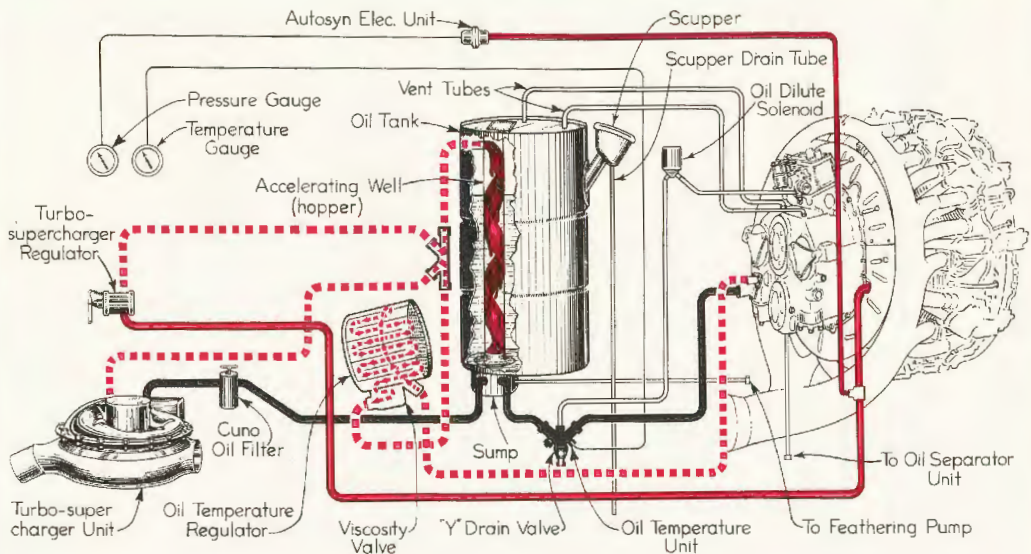

LEGEND  
 Line from Tank ———  
 Return to Tank - - - -  
 Pressure ———

TURBO REGULATOR OIL LINE OMITTED WHEN ELECTRONIC CONTROL IS USED.

**DIAGRAM OF OIL SYSTEM**



**OIL DILUTION PROCEDURE****CAUTION:**

1. Operate engines at 800 to 1000 rpm.
2. Dilute all engines simultaneously with gong bar if indicated oil pressures do not exceed a 10-lb. variation. If this tolerance is exceeded, dilute each engine separately.
3. Maintain oil temperature below 40°C (104°F).
4. Before diluting all engines simultaneously, establish the average indicated pressure. If engines are diluted individually, oil pressure of each must be noted before dilution.
5. Dilute engine oil as follows, for ground temperature as shown:  
 +4° to -26°C (+40° to -15°F) depress dilution switch until a 35% oil pressure reduction is accomplished.  
 -26° to -40°C (-15° to -40°F) depress dilution switch until a 50% pressure reduction is accomplished.
6. It is important to leave dilution switches engaged until propellers cease rotating, so undiluted oil will not be drawn into the engine.
7. Under extremely low temperatures, locally recommended procedure should be followed.
8. On airplanes having oil-operated turbo regulators, operate turbo controls over complete range from low to high blower and return at the minimum rate of 8 seconds per cycle (at least 14 complete movements from low to high blower and return) during the last 2 minutes of the dilution period.
9. During the last 2 minutes of the dilution period depress propeller feathering switch until drop of 400 rpm is observed. Pull out feathering switch and allow rpm to return to normal. Repeat this operation 3 times.

**NOTE:** Overdilution causes sludge and carbon to be loosened in the engine, causing oil screens to collapse and oil lines to clog. This constitutes a fire hazard, and may cause engine failure as well.

**FUEL SYSTEM**

The following fuel capacity is provided in the B-24.

Main system—4 sets of 3 cells each; total 12 cells; total capacity 2344 U. S. Gallons:

- No. 1 tank—616 U. S. Gallons
- No. 2 tank—556 U. S. Gallons
- No. 3 tank—556 U. S. Gallons
- No. 4 tank—616 U. S. Gallons

Auxiliary wing system—2 sets of 3 cells each; total 6 cells; total capacity 450 U. S. Gallons:

- Left-hand tank—225 U. S. Gallons
- Right-hand tank—225 U. S. Gallons

Auxiliary bomb bay system—2 separate cells with a total capacity of 782 U. S. Gallons:

- Left-hand tank—391 U. S. Gallons
- Right-hand tank—391 U. S. Gallons

**Fuel System Indicators**

Pressure—Gages measuring fuel pressure at the carburetors are mounted on the copilot's instrument panel.

Quantity—Sight gages, mounted on the forward face of bulkhead at Station 4.1, left side,

## RESTRICTED

show the quantity of fuel in each of the main systems. In case of damage to the gage vent or supply lines, shut-off valves are provided on top of the gages and at the supply takeoff under the center section, to prevent the loss of fuel.

No fuel quantity gages are provided in either auxiliary system. A glass tube between the wing auxiliary selector valve and the transfer pump shows flow of fuel being transferred.

**Note:** Inclinometer on outboard side of fuel gages must read neutral when gages are read.

**Warning: Aromatic Fuel**—Do not use aromatic fuel in the system unless all units carry the markings which designate them as suitable for aromatic fuel.

Aromatic-resistant, self-sealing fuel hose can be identified by a single red stripe and correct part number in red. Part number and name of manufacturer are stamped every 12 inches: AR-145, or G-145 Goodyear; AR-184 Goodrich or Boston Woven Hose; AR-250 U. S. Rubber.

Aromatic-resistant fuel hose, not self-sealing, can be identified by a white stripe and a broken red line. This hose is used only for connection of aluminum alloy tubing to fuel system lines (engine-driven fuel pump to carburetor line and fuel cell vent system lines.)

All other parts of the systems are marked with an A if suitable for aromatic fuels. Units made of aluminum alloy carry an A painted in red or stamped on the aluminum body.

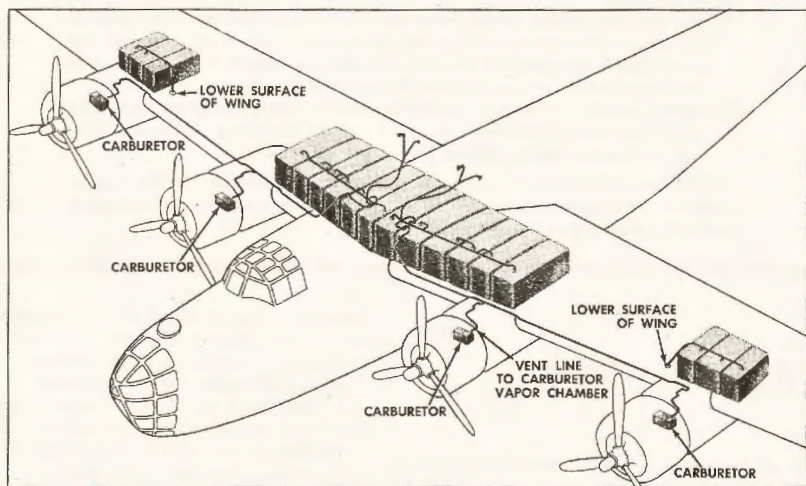

Fuel System

### Main Fuel System

1. Twelve self-sealing fuel cells in the wing center section. There are 4 sets of 3 cells each. In normal operation each engine is served by one set.

2. Four electrically-driven booster pumps with strainers (one for each set of cells). They are usually located in the bomb bay just under the cells.

3. Four triple-port shut-off valves. On each valve: One port leads to an engine; one port leads to a set of cells; and one port interconnects to the other 3 valves by way of the cross-feed connection which allows fuel from any set of cells to serve any engine in an emergency, and permits equalizing flow between systems. These valves are under the front spar in the bomb bay.

4. Four engine-driven pumps with strainers are located one in each nacelle.

5. Four electrically controlled primers are located one on each carburetor.

6. Two vent systems for the main fuel systems. One of these vents the fuel system serving Engines 1 and 2; namely, the left bank of main fuel cells; the left fuel gauge; and the carburetors on the left wing. In the same manner the other vent system vents the fuel system serving Engines 3 and 4 on the right wing.

7. Two vent systems for the wing auxiliary fuel system. One of these vents the 3 cells in the left wing; similarly, the other vents the 3 auxiliary cells in the right wing.

8. One electrically driven transfer pump above the center wing section allows transfer of fuel to a main system through the transfer panel.

9. Drain lines for the wing fuel cell compartments and for the 4 fuel booster pumps empty overboard under the bulkhead at Station 5.0. The 2 shut-off valves are normally open, but must be closed during combat.

10. Main fuel system supply lines and cell interconnecting, or manifold, lines are self-sealing.

### Fuel Transfer From One Main System to Another

Procedure for transferring fuel from one main system to another is vital information. Illustrations give examples of fuel transfer methods which are typical of the 3 different arrangements in the main systems. Airplane serial numbers, recorded on the nameplate on the left of the pilots' pedestal, are an index to the selection of the proper illustration of fuel transfer.

### Wing Auxiliary Fuel System

1. Six self-sealing fuel cells, 3 in each wing, are located outboard of the wheel wells.

2. Transfer of fuel from the wing auxiliary systems is controlled at 2 panels located above the wing center section. The aft or auxiliary selector valve panel contains one 2-way selector shut-off valve and strainer. This valve selects the auxiliary system, left or right, from which fuel is to be transferred. In later installations the forward or auxiliary transfer panel contains two 2-way selector shut-off valves, the transfer pump, and switch. These valves select the main system, 1, 2, 3, or 4, or any combination thereof, into which fuel is to be transferred.

3. Two venting systems, one for each auxiliary set of 3 cells, right and left.

4. Auxiliary wing cell fuel supply lines are self-sealing.

### Fuel Transfer—Wing Auxiliary System to Main System

Illustrations give examples of fuel transfer methods which are typical of the 2 different arrangements to be found in wing auxiliary systems.

The rate of fuel transfer in this system is approximately 5 U.S. gallons per minute, or 300 gallons per hour. In case of emergency, should the pump fail, fuel transfer from either auxiliary set of wing cells to the main system can be effected by lowering the opposite wing from 3° to 5°. The rate of fuel flow under this condition is approximately 3 gallons per minute, or 180 gallons per hour.

RESTRICTED

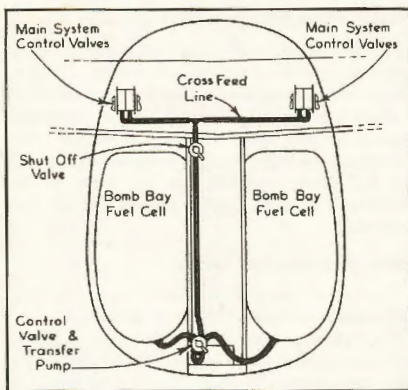

Bomb Bay Auxiliary Fuel System

#### Bomb Bay Auxiliary Fuel System

1. Two self-sealing fuel cells are provided, one on each side of the catwalk in the forward bomb bay.
2. In later installations a 2-way selector valve and transfer pump are mounted on the catwalk at Station 5.0, and another 2-way shutoff drain valve is connected to a T fitting in the cross-feed line.

#### Fuel Transfer—Bomb Bay Auxiliary System to Main System

Illustrations on the following pages give examples of fuel transfer methods which are typical of the 3 different arrangements to be found in bomb bay auxiliary systems.

The rate of fuel transfer in this system is approximately 10 U.S. gallons per minute, or 600 gallons per hour.

### PRECAUTIONS WHEN TRANSFERRING FUEL

1. Know the system for transferring fuel in the particular airplane you are flying.
2. Start transfer as soon as fuel in main tank is consumed to a point where transfer can be accomplished. This assures you sufficient fuel to return to your base in case of failure of transfer system, improves loading, and reduces fire hazards.
3. Radio equipment and auxiliary hydraulic pumps off during transfer.
4. Warn crew that fuel will be transferred—no smoking.
5. At the end of 10 minutes, turn the transfer pump off, shut off all transfer valves, and determine that fuel is being properly transferred before continuing.

6. If transferring fuel from bomb bay tanks:
  - a. Remove bomb bay tank cap for inspection. Return cap to proper place before resuming transfer operation.
  - b. One crew member should be on watch in bomb bay at all times when transfer is in progress. At any indication of overflow, bomb bay transfer pump should be stopped and thorough inspection conducted.
7. Bomb bay doors should be open slightly (6 to 8 inches) before and during transfer.
8. Don't attempt to fill more than one main tank at a time as all engines connected to the crossfeed manifold will stop running when the bomb bay tanks are empty and air is introduced into crossfeed manifold.
9. Do not turn on fuel pump switch until selector valves are set; do not change setting of selector valves while fuel pump is on.
10. Do not leave selector valves "ON" or "BOTH ON" after transfer is completed.

FILLING ONE MAIN SYSTEM FROM ANOTHER USING U HOSES WHILE FEEDING FOUR ENGINES ON  
B-24 AIRPLANES, THROUGH No. 41-1193B  
EXAMPLE: FUEL TRANSFER FROM No. 4 MAIN SYSTEM TO No. 2 MAIN SYSTEM

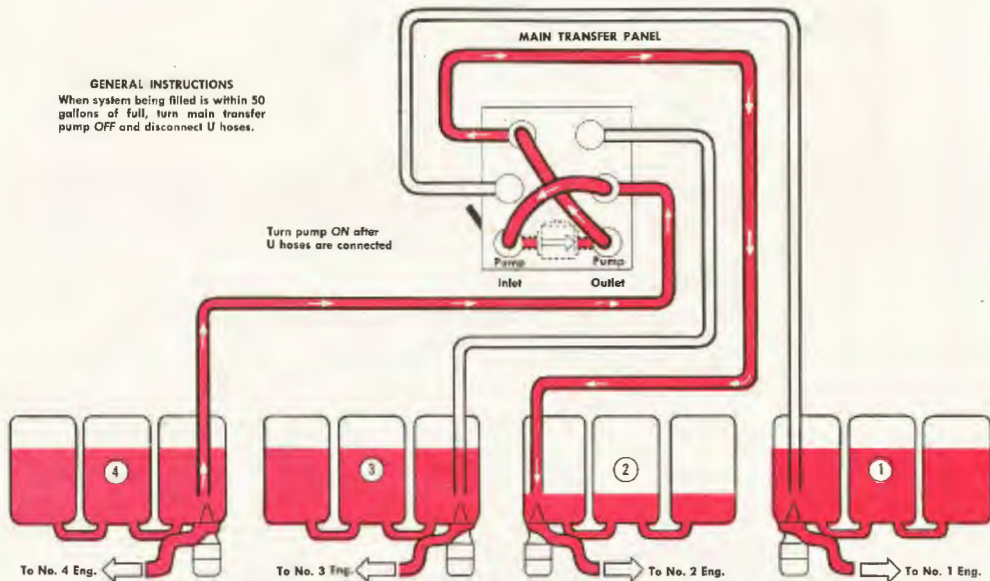

FILLING ONE MAIN SYSTEM FROM ANOTHER WHILE FEEDING FOUR ENGINES ON B-24 AIRPLANES  
FROM No. 41-23640 TO 42-40917

EXAMPLE: FUEL TRANSFER FROM No. 1 MAIN SYSTEM TO No. 4 MAIN SYSTEM

GENERAL INSTRUCTIONS

To speed transfer use booster pumps and cross-feed line in conjunction with U hoses.

When system being filled is within 50 gallons of full, turn main transfer pump OFF and disconnect hoses. Reset selector valves of system being filled and system being drained to **TANK TO ENGINE**.

When any main system is emptied set its selector valve to **CROSS FEED TO ENGINE** and set the selector valves of the three remaining systems to **TANK TO ENGINE AND CROSS FEED**.

Turn main transfer pump ON after selector valves are set and hoses are connected.

CAUTION: Do not fill more than one system at a time and have radio OFF.

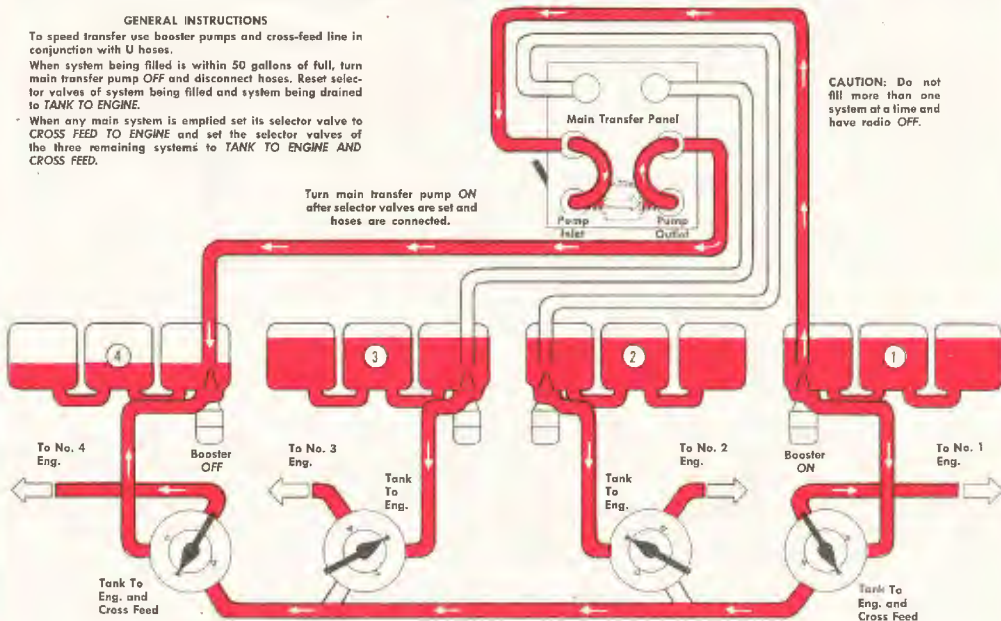

When fuel is low in all systems and it is desired to level tanks, set selector valves of all main systems to **TANK TO ENGINE AND CROSSFEED**, with booster pumps OFF. As soon as tanks are leveled, turn selectors back to **TANK TO ENGINE**.

FILLING ONE MAIN SYSTEM FROM ANOTHER USING CROSS FEED WHILE FEEDING FOUR ENGINES  
 ON B-24 AIRPLANES, ON AND AFTER No. 42-40918  
 EXAMPLE: FUEL TRANSFER FROM No. 1 MAIN SYSTEM TO No. 3 MAIN SYSTEM

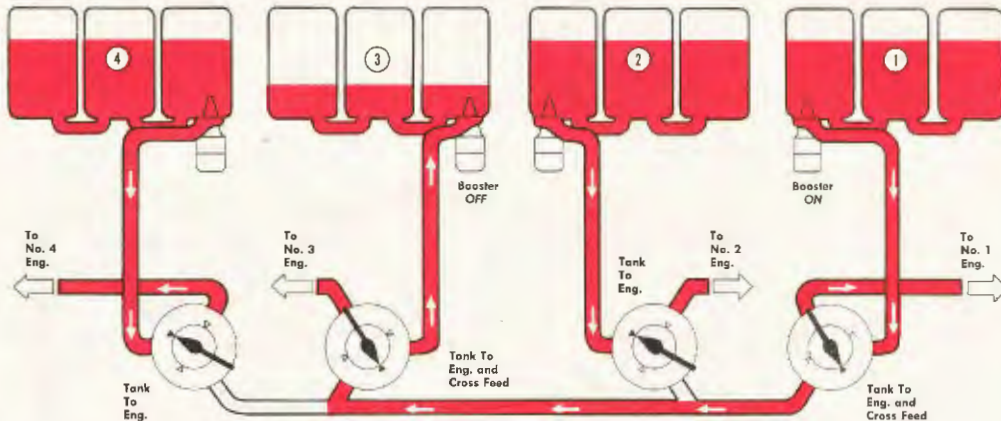

#### GENERAL INSTRUCTIONS

When system being filled is within 50 gallons of full, reset selector valves of system being filled and system being drained to **TANK TO ENGINE**.

When any main system is emptied set its selector valve to **CROSS FEED TO ENGINE** and set the selector valves of three remaining systems to **TANK TO ENGINE AND CROSS FEED**.

When fuel is low in all systems and it is desired to level tanks, set selector valves of all main systems to **TANK TO ENGINE AND CROSSFEED**, with booster pumps **OFF**. As soon as tanks are leveled, turn selectors back to **TANK TO ENGINE**.

**CAUTION:** Do not fill more than one system at a time and have radio **OFF**.

FILLING ONE MAIN SYSTEM FROM THE AUXILIARY WING SYSTEMS USING U CONNECTORS WHILE  
FEEDING FOUR ENGINES ON B-24 AIRPLANES, FROM No. 41-23640 TO No. 42-40917  
EXAMPLE: FUEL TRANSFER FROM L. H. AUXILIARY  
WING SYSTEM TO No. 3 MAIN SYSTEM

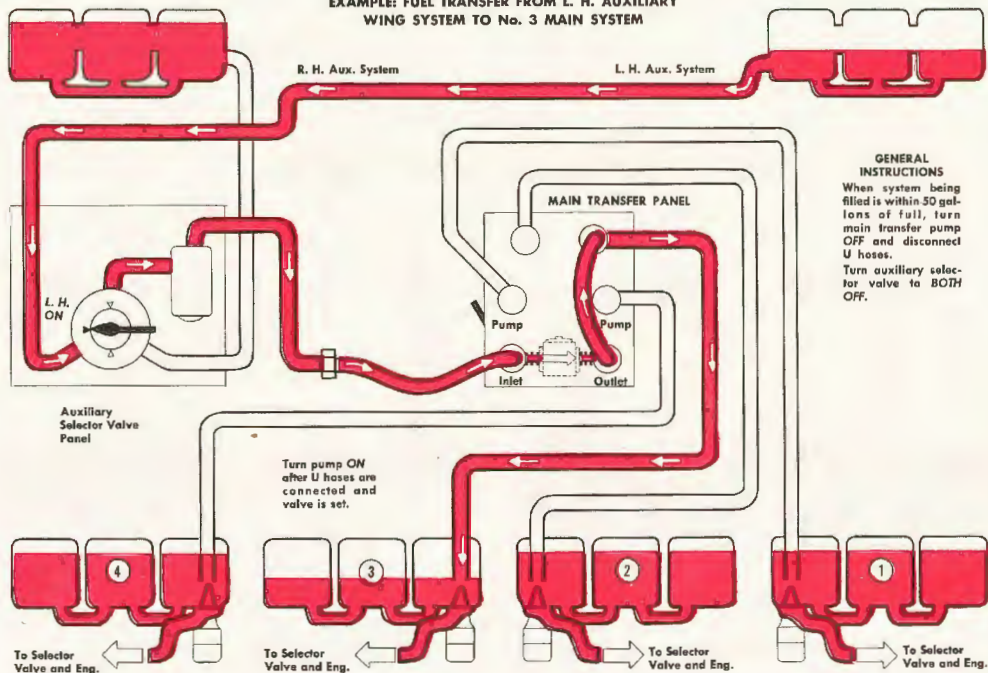



FILLING THE MAIN SYSTEMS FROM THE AUXILIARY WING SYSTEMS WHILE FEEDING FOUR ENGINES ON  
 B-24 AIRPLANES, ON AND AFTER No. 42-40918  
 EXAMPLE: FUEL TRANSFER FROM BOTH AUXILIARY  
 WING SYSTEMS TO No. 3 AND No. 4 MAIN SYSTEMS

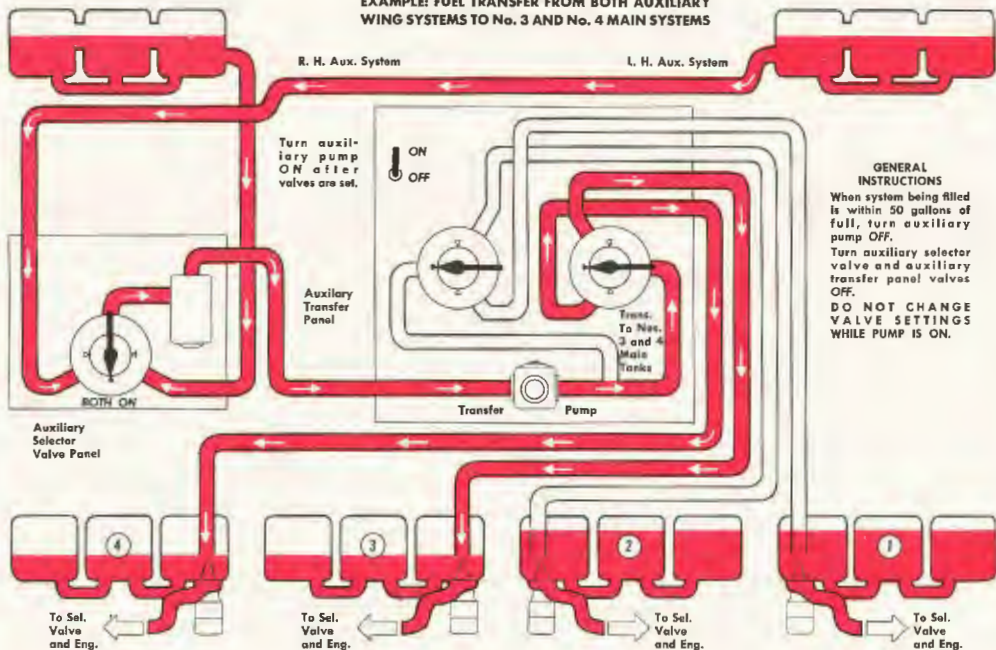

FILLING ONE MAIN SYSTEM FROM THE BOMB BAY FUEL CELLS USING U HOSES WHILE FEEDING FOUR ENGINES ON B-24 AIRPLANES, FROM No. 41-11587 TO No. 41-24175  
 EXAMPLE: FUEL TRANSFER FROM BOTH BOMB BAY FUEL CELLS TO No. 2 MAIN SYSTEM

GENERAL INSTRUCTIONS

When system being filled is within 50 gallons of full, turn both main transfer and bomb bay pump OFF and disconnect hoses. Turn bomb bay selector valve to BOTH OFF.  
 CAUTION: Caps on the bomb bay fuel cells should not be removed during transfer operations. One crew member should be on guard in the bomb bay at all times during transfer. At any indication of fuel overflow stop bomb bay booster pump and investigate.

Turn main transfer pump and bomb bay booster pump ON after bomb bay selector valve is set and hoses are connected.

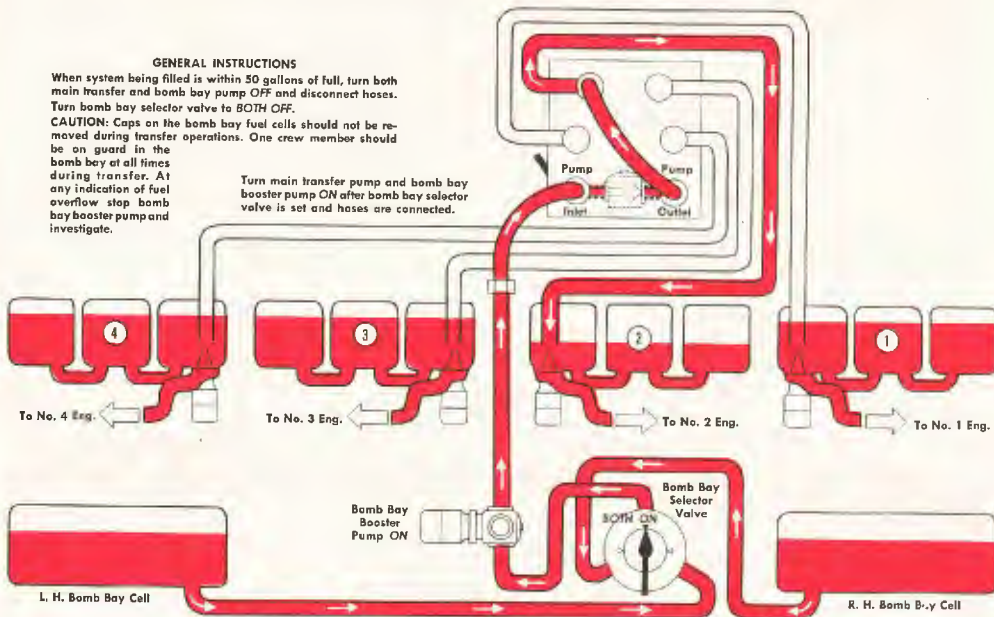

FILLING ONE MAIN SYSTEM FROM A BOMB BAY FUEL CELL WHILE FEEDING FOUR ENGINES ON  
B-24 AIRPLANES, ON AND AFTER No. 42-40918

EXAMPLE: FUEL TRANSFER FROM L. H. BOMB BAY FUEL CELL TO NO. 4 MAIN SYSTEM

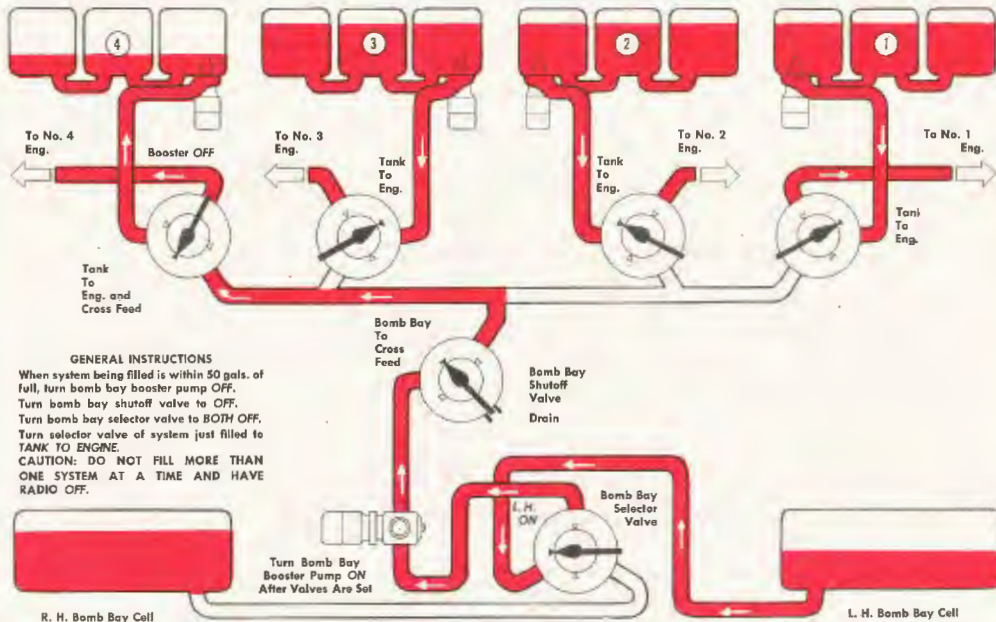

FILLING ONE MAIN SYSTEM FROM A BOMB BAY FUEL CELL WHILE FEEDING FOUR ENGINES ON  
B-24 AIRPLANES, FROM No. 41-24176 TO No. 42-40917  
EXAMPLE: FUEL TRANSFER FROM R. H. BOMB BAY FUEL CELL TO No. 1 MAIN SYSTEM

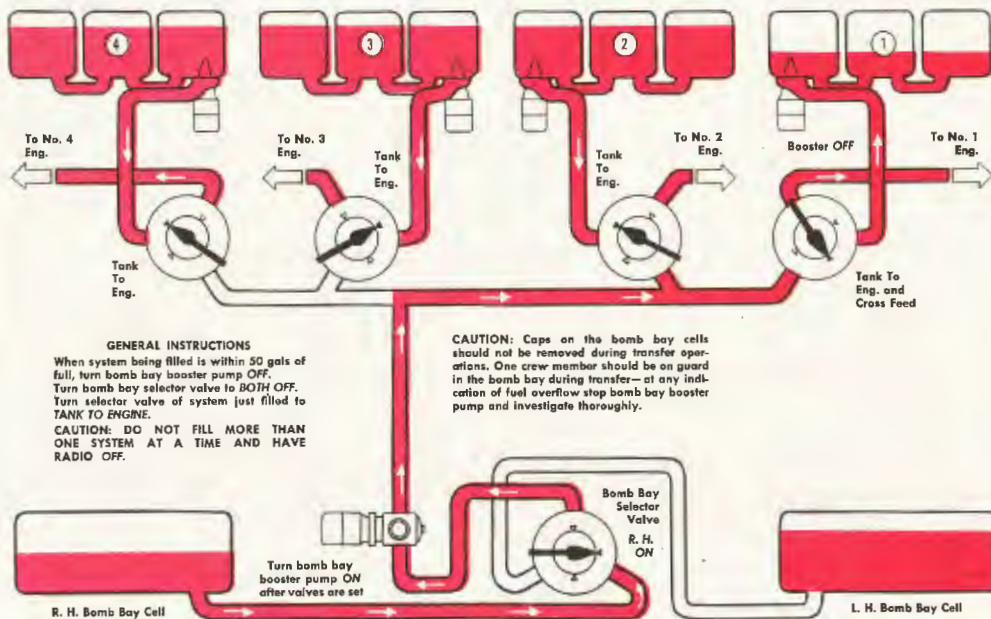

## HEATING SYSTEMS

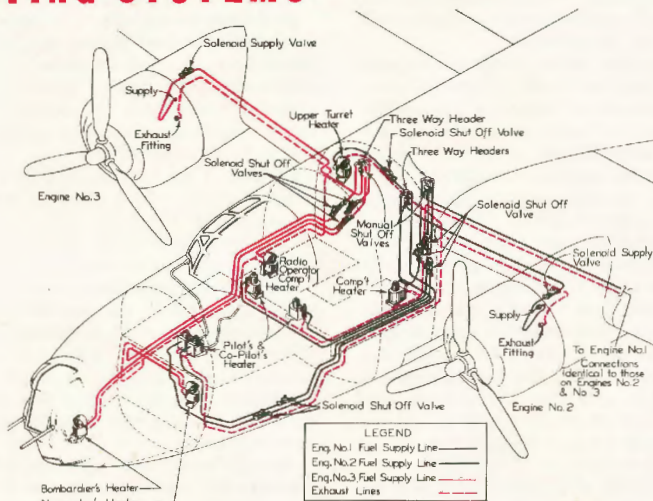
**General**

Two methods of supplying warmth are provided in the airplane: fuel-fired heaters and electrically heated clothing. (Also see section on exhaust heat system for late series B-24's -pp. 149-150.)

**Heaters**

Stewart-Warner circulating air heaters are provided for pilot, copilot, radio operator, bombardier, and navigator, and are arranged in

separate systems of source of supply, control, and heater grouping in most aircraft, as shown in the table below.

A switch, at the right of the copilot, operates a master solenoid valve which controls Group No. 1. A switch at the bombardier's panel serves similarly for Group No. 2.

Manually controlled shut-off valves attached to the 3-way headers are just forward of the front spar, right and left, to permit shutting off fuel supply to heaters in case of master solenoid valve failure.

**ENGINE NO. 2****SOLENOID SUPPLY VALVE (MAIN)**

3-way header (Aux.)  
Indiv. shut-off valve  
Indiv. shut-off valve  
Indiv. shut-off valve

**GROUP 1**

Pilot  
Copilot  
Top Gunner

**ENGINE NO. 3****SOLENOID SUPPLY VALVE (MAIN)**

3-way header (Aux.)  
Indiv. shut-off valve  
Indiv. shut-off valve  
Indiv. shut-off valve

**GROUP 2**

Radio Operator  
Bombardier  
Navigator

## RESTRICTED

If the manifold pressure is reduced below 15" on an engine, there is not sufficient pressure to supply fuel and the heaters supplied by that engine will be extinguished.

On later systems, there is in the line between each heater and the header, a solenoid valve, for the control of that individual heater. The individual solenoid valves are useful only as a means of shutting off one heater while retaining the use of the remaining units. This may be accomplished by disconnecting the electrical plug at the solenoid of any selected heating unit. Combustion exhaust fumes are led back to the engine induction systems through asbestos-protected tubes. There are no valves in the exhaust system. Each heater is equipped with an electric circulating fan which operates from the same control circuits as the master solenoids. Igniters to ignite the fuel mixture are incorporated in each heater and operate automatically when master switch is turned on. The copilot's switch is a three-position switch; the three positions are "HEATERS ON," "HEATERS OFF," and "DEFROST." With the switch in position to defrost only, the circulations fans will operate and no heat will be generated. The bombardier's switch has only two positions, "ON" and "OFF."

To defrost windshields, without heat, turn on the heater switch to defrost and pull out defroster knobs. This deflects air blast into windshield duct system. Pull out and attach de-

froster hose with the strap clamp mounted at the bottom of the windshield.

To defrost windshields with heat, turn the heater switch to heat position and pull out defroster knob. This deflects heated air blast into windshield duct system. Pull out and attach defroster hose. To stop defrosting action, push defroster knob in and turn heated off by means of the copilot's switch.

**Caution:** If the heaters start smoking after being shut off, reduce manifold pressure on No. 2 and No. 3 engines to 15" and turn on heaters until smoking has stopped. Then turn off heaters and resume manifold pressure.

This action is necessary in case the solenoid valves stick and do not shut off the fuel-air mixture after the electrical system is shut off. This permits the fuel-air mixture to burn without the fans circulating the air, which will cause the heater oven to overheat and eventually burn out. Smoking will also occur if there is dust on the fins.

**Note:** Turn the heater on before entering extremely cold conditions to prevent solenoids from freezing up.

If the fan stops, check fuses immediately or heating element will overheat and burn out.

### Heated Clothing

Electrically heated flying suits may be plugged in at all crew stations and in the bomb bay. Individual rheostats control temperature.



## EXHAUST HEAT SYSTEM IN LATE B-24'S

In some late series B-24's, heat exchangers in the engine exhausts provide heat for the cabin, for anti-icing of the wing and empennage leading edges, and for defrosting the windshields, nose turret, and top turret.

Cabin heat comes from the exhausts of the 2 inboard engines. Air temperature in the system is regulated automatically by a valve which admits cold air to the ducts when the temperature rises above pre-set limits. Controls for this heating system include switches on the pilot's control pedestal, manually operated registers in the duct outlets, and manually operated damper valves in the ducts themselves.

Heat for anti-icing the leading edges of the wing center section and the empennage also comes from the inboard engines; the outboard engines provide heat for anti-icing the outer panel leading edges and wingtips. Control switches are on the same panel as the cabin heat switches.

Aircraft with this heating system have double plate glass windshields. Warm air for defrosting, supplied through ducts from the main cabin system, is introduced between the 2 panes. The inner panes are removable, and there is stowage space for them on the left side of the radio compartment.

### Operation

Usually only one cabin heat switch needs to be turned on. With either No. 2 or No. 3 switch on, you can increase heat for the cabin by turning the empennage anti-icing switch off if no icing conditions exist, thereby cutting off hot air flow to the tail and directing more heat to the cabin. **Caution:** Don't turn empennage switch off if both No. 2 and No. 3 switches are on.

To prevent formation of ice on wings, tail and windshields, turn on all cabin heat and anti-icing switches, including the empennage switch,

as soon as icing conditions are anticipated and before ice starts to form.

### Use of Manually Operated Dampers

The damper controlling the 2 windshield ducts is over the forward end of the radio operator's table on the aft face of the armor plate behind the copilot's seat. Open this damper only to prevent formation of ice on the windshields.

The damper controlling the main heater duct on the lower left hand side of the cabin is on the forward bulkhead of the left hand bomb bay, near the top. The damper for the right hand main cabin heater duct is on the aft bulkhead of the radio operator's compartment near the floor on the right side. Don't close these dampers except to divert more hot air to windshield defrosters. Control cabin heat exclusively with the outlet registers and with No. 2 and No. 3 switches.

The damper which regulates the top turret defroster is on the aft bulkhead of the radio operator's compartment, above the right hand main duct damper. Don't open the defroster damper except to defrost top turret or compartment side windows.

Dampers for the ducts in the bombardier's compartment are on the forward end of the copilot's duct, in the nose compartment near navigator's table. Don't open these dampers except when necessary.

### *Important*

A warning light on the pilot's pedestal will indicate the presence of carbon monoxide in the cabin air if one of the heat exchangers should leak. A button near the warning light re-sets the warning light relay when the danger of carbon monoxide is ended. Turn off cabin heat switches (either No. 2 or No. 3) immediately if the warning light goes on. Don't use the cabin heat system unless the monoxide detector is installed and known to be working properly.

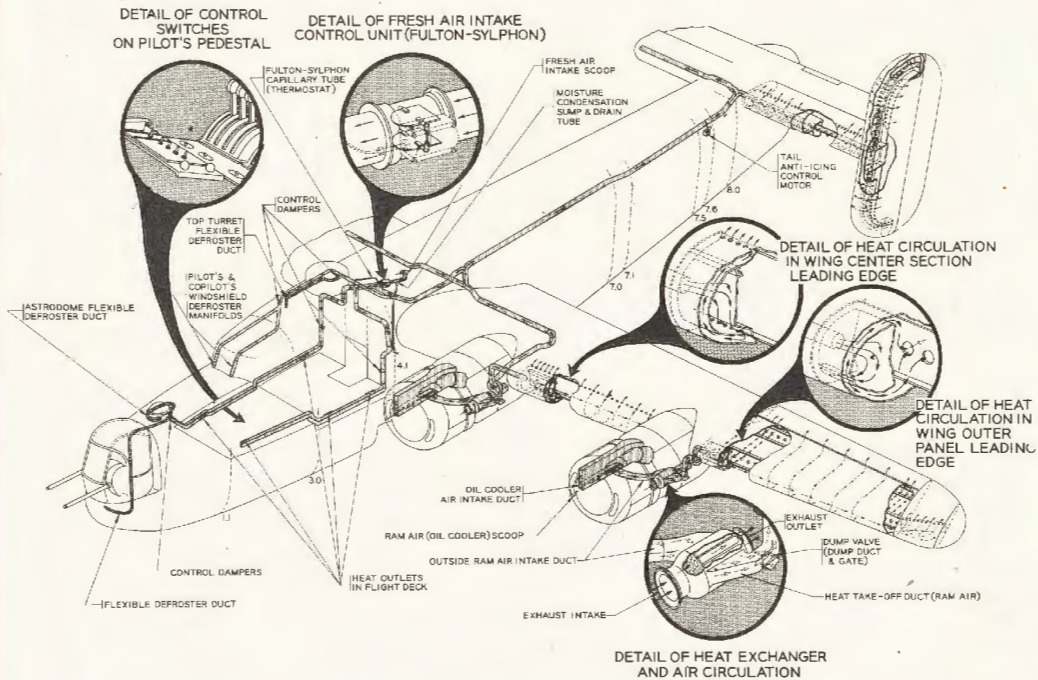

**EXHAUST HEAT SYSTEM IN SOME LATE B-24'S**



# ANTI-ICERS, DE-ICERS AND DEFROSTERS

The problem of icing and weather flying is too big a subject for this book, which is restricted in its scope to specific problems of the B-24. That does not relieve the B-24 pilot of the obligation to know weather flying and to know icing problems before attempting flights in which he may have to use his anti-icing and de-icing equipment. Intelligent use of anti-icing and de-icing equipment requires knowledge of the various kinds of ice, when to stay at your altitude, when to ascend and when to descend, and the circumstances under which your plane is likely to ice up. You'll find information on this subject in P. I. F., under "Cold Weather Operation" in the T. O. for the B-24, in "Instrument Flying in Weather," and in training films. Don't miss an opportunity to learn all you can about icing and weather flying. In certain theaters much larger losses are charged to weather than to enemy action. Your gunners can't drive off the weather.

**Warning:** The pilot who takes off without complete information on icing levels, relative saturation, and the probability of encountering ice is his own worst enemy. The sky makes no allowances for incompetence. If you can't read the weather charts, ask the weather officer. The government pays him a salary for answering your questions.

Remember that the weather that usually comes with ice brings other distraction: static noises, strong possibility of intermittent radio failure, increased fuel consumption under an icing load, and instrument flying conditions. You get uneasy and want to descend or mill around and lose your way. Usually it is better either to do a 180° turn or fly out your ETA if you have adequate fuel. Don't get panicky. Know your weather and know your icing equipment.

RESTRICTED

RESTRICTED

## Anti-icers and De-icers Distinguished

Distinguish between these 2 types of equipment. One will prevent icing but has very limited or no effect in removing ice. The other will remove ice. Anti-icers should be started before ice forms. De-icers are more effective after ice has formed hard enough so it will crack off.

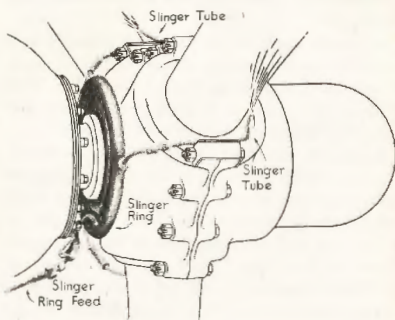

SLINGER RING DETAIL

## Propeller Anti-Icing System

It is most important to anticipate propeller icing by knowing the condition of the atmosphere you are flying through. Remember this is anti-icing equipment. Slinger rings distribute fluid to spread a protective film over the blades so ice won't form. The film will keep ice off when it won't take it off. Therefore, anticipate ice.

You can tell the propellers are icing up if you note spotty discoloration on them or if small pieces of ice are thrown off against the fuselage. Immediately increase the flow of fluid enough to stop further icing. But keep in mind the probable length of time you will need propeller anti-icing and conserve fluid accordingly.

## Equipment

Ice prevention fluid, isopropyl alcohol, is supplied to the slinger rings on each propeller by 2 pumps taking suction from a reservoir tank. On early airplanes this is a 6-gallon tank located

## RESTRICTED

under the flight deck and can be filled in flight. On later airplanes it is a 21-gallon tank located on the half deck, refillable only from outside the fuselage. Plug valves, normally safetied open, permit shut-off from tank to either pump. Valves are located directly under the 6-gallon tank, and on the 21-gallon tank installation shut-off valves are located on the aft face of bulkhead at Station 4.1 high in the bomb bay, right side.

A single rheostat on the instrument panel simultaneously controls the 2 electric pumps. A quantity gage is on top of the tanks. The rheostat flow control is marked in gallons per hour showing total flow for all 4 engines.

**Operation:** To start motor turn the rheostat to the extreme right. This will cause pumps to give maximum output and will clean the lines out. Leave in this position about 2 minutes to fill tubing and start the flow of the anti-icing liquid to propellers. Then adjust rheostats to provide the minimum amount of fluid necessary to keep the propellers free of ice. A flow of 1 to 2 gallons per hour will take care of light to moderate ice.

**Wing and Empennage De-icing:** You can see the ice forming on wing leading edges. Usually it will start as a narrow white line along the center of the de-icing boot and gradually widen. Avoid using boots until ice is hard enough to crack off as the boots inflate. Don't allow ice to build back beyond the effective boot area, or when boots crack it loose a sharp edge of ice will remain at the edge of the boot. Then additional ice will build on this, creating burble and destroying lift. The B-24 will carry a good load of ice if necessary, but remember you are supported by a highly efficient wing. Anything that disturbs its normal lift characteristics is not good.

Normally rime ice and clear ice will crack off immediately when the de-icer boots start to operate. However, you may encounter ice which seems rubber-like; it will appear to stretch instead of crack when the boot starts to operate. Watch closely. If the ice doesn't crack as the boots start to operate, turn de-icers off and wait for the ice to harden; otherwise a hollow space will be formed beneath the ice and

boots will inflate without removing it. It is important to know exactly how de-icing equipment works.

**Equipment:** De-icing is accomplished by rubber shoes on leading edges of wings and stabilizer. The pressure side of engine-operated vacuum pumps on engine No. 1 and engine No. 2 furnish air for inflation. The suction side of either pump furnishes suction for deflation; the suction side of the other pump furnishes suction for the vacuum-operated instruments.

In case of failure of either pump, the remaining pump will furnish sufficient pressure for inflation. In such an emergency, be sure that the vacuum selector valve handle, on the forward face of Station 4.1, is set so that the instruments receive the vacuum from the pump which is operating. This means that the boots will have to depend on external air pressure for deflation.

A horizontal lever on the copilot's panel is cable-connected to a control valve high on the front spar in the bomb bay. Until this valve is opened, the pressure from both pumps escapes overboard and the suction from one engine pump keeps the boots deflated. When the valve is opened, pressure is distributed to and inflates the boots in a set order of sequence. In case the cable between the control lever and the valve in the bomb bay should break or become disconnected, valve in the bomb bay can be moved by hand to operate boots. A suction gage on pilot's panel shows vacuum level in system for instruments only. It gives no indication of de-icer suction.

**Windshield Anti-icing System:** Some B-24 airplanes are equipped with hand pumps which force a spray of isopropyl alcohol on the windshields to prevent ice formation. On these installations, 2 separate tubes from the reservoir deliver fluid, one to the copilot's hand pump, outboard of his seat, and the other to the bombardier's hand pump on the right side of his windshield. Two positions, **left** and **right**, are indicated on the copilot's hand pump to direct the fluid, as desired, to either pilot's windshield. This selection is made by pressing the handle **down**. Note that this is an anti-icing fluid. Use as the first suspicion of windshield icing when

ice starts to form in the corners of windshield. It is lots easier to keep ice from forming than to get rid of it. The film deposited by the fluid keeps ice from forming.

**Defrosters:** The bombardier's and pilots' heaters are fitted with flexible defroster ducts to direct warm air to bombardier's sighting window and to pilots' windshields. On some aircraft the navigator's heater is similarly equipped for defrosting the astrodome. On the pilots' heaters, push-pull Ahrens controls on instrument panel; and on the bombardier's and navigator's heaters, hand operated shutters, permit use of heaters for heating or for defrosting.

**Pitot Heater:** Your airspeed indicator reacts to the pressure of incoming air in the pitot tubes. If moisture gets in the tube and freezes, or forms over the outside, your airspeed will appear to be falling off rapidly when in reality it is the same as before.

Your first thought before entering clouds



DIAGRAM OF PITOT TUBE HEATER

should be to turn on your pitot heaters, especially when the temperature is near  $0^{\circ}\text{C}$ . This will keep ice from forming. Warm, wet air can also block off your airspeed indication during a heavy rain. Use the pitot heater. Pilots have been known to keep adding more and more power trying to maintain altitude and airspeed, flying for several hours at dangerously high power, when nothing was wrong except a little ice in the pitot head.

## OXYGEN SYSTEM

There are 2 types of oxygen supply systems in use: The constant flow and the demand system.

**Constant Flow**—On ships up to 42-40217 inclusive.

This type uses either A8 or A8-A masks. The mask connects to the regulator with a long, slender hose. Small leaks around the mask are relatively unimportant in this type because of the constant flow of oxygen from the tank through the regulator. With this steady flow the length of the hose is immaterial, as no air cushion can back up in the hose to the regulator.

**Demand System**—On No. 42-40218 and subsequent airplanes.

This type uses either A9, A10, A10-R, or B14 masks. The mask connects to the regulator by a short, stubby hose. This system provides the proper amount of oxygen at any altitude.

### Operational Precautions

#### Before Flight:

1. Check pressure in oxygen cylinders. Cylinders should be filled to 450 lb. sq. in.; their pressure will drop to approximately 400 lb. sq. in. when they cool.
2. Check flow of oxygen through regulators and masks. Wherever possible, have oxygen officer on ground check equipment.
3. Be certain hose is tight at regulator outlet collar.
4. Be certain male end of rapid disconnect fitting rubber gasket is in place.
5. Mask should fit airtight, and when so fitted it should be worn only by the individual for whom it was adjusted.
6. Clip hose, by means of the spring clip, to

clothing or to parachute harness, not too far below chin.

7. Check pressure gage.

#### During Flight:

1. To check oxygen flow to mask from regulator in the constant-flow type pinch hose lightly several times. A hiss will indicate that oxygen is flowing.

2. At altitudes over 34,000 feet the reservoir bag in the constant flow should not collapse. This can be checked by holding hand loosely around reservoir bag while **breathing normally**. Quick or deep breaths will collapse bag. Be careful not to collapse bag while making this check.

3. Type A8 and A8-A masks can be freed of ice formation by squeezing air outlets on cheeks in mask.

4. In demand system, watch the flow indicator to make sure you are getting oxygen.

#### After Flight:

1. Wipe mask dry, or if possible, wash with soap and water and dry thoroughly.
2. Do not lend your mask, as strap adjustments may be altered by someone else.
3. Inspect for cracks and leaks in face piece.

#### Safety Measures:

1. Normally, **keep** the regulator on the demand system with the auto-mix turned "ON."
2. Use oxygen on all flights above 10,000 feet.
3. Each crew member should have available one **walk-around** bottle. The bottle should be tested before the airplane leaves the ground. If it is necessary for a crew member to leave his station the bottle can be quickly attached to the oxygen mask. The bottle can be refilled from the ship's regular supply.
4. Memorize location of bailout bottles. These bottles are used, when abandoning ship, as an oxygen supply until reaching an altitude where oxygen is not necessary.
5. In night flying use oxygen all the time to preserve maximum efficiency of night vision.

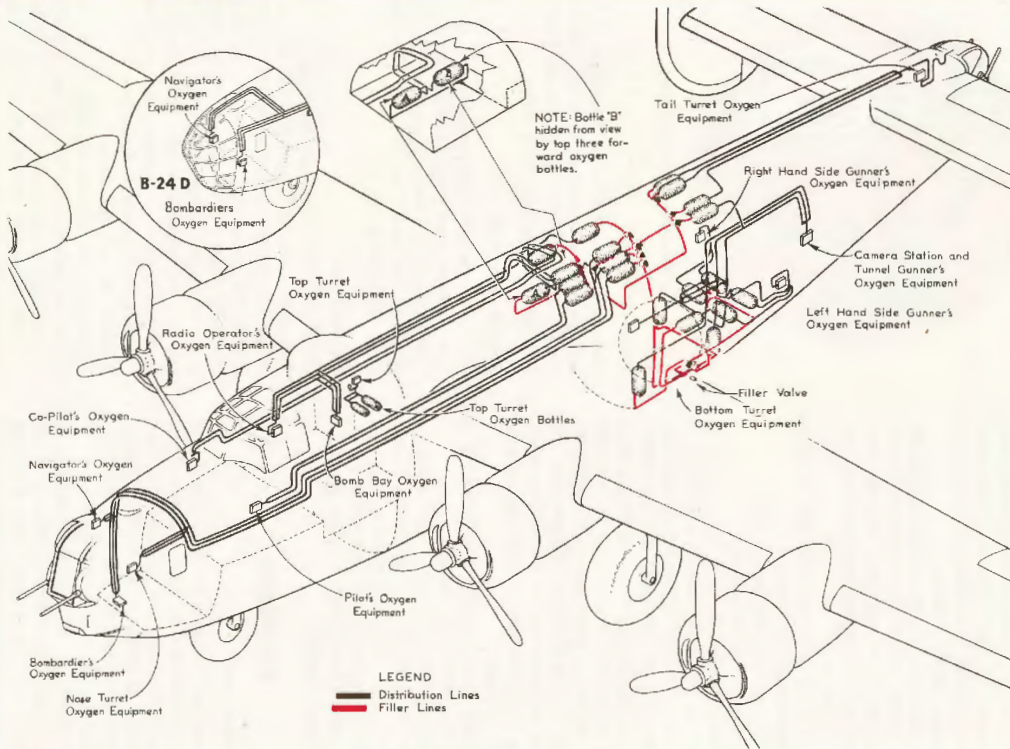

**OXYGEN SYSTEM - 24 BOTTLE**

## RESTRICTED

6. Crew members are warned against eating gas-forming foods or drinking alcoholic beverages within 24 hours before high altitude flying. Gas expands at high altitudes. Abdominal cramps will result, retarding mental alertness and reducing physical fitness.

7. The amount of oxygen needed by each individual varies. Active crew members require more oxygen than those at rest. The most common symptoms which indicate a lack of oxygen at high altitude are:

- a. The body feels extremely cold or warm (sweating may occur).
- b. Unusual exhilaration.
- c. Lassitude and sleepiness.
- d. Mind not alert.

8. Lack of oxygen at first is a deceiver; it gives a false sense of exhilaration and self-confidence. Do not wait until the last minute to turn on the oxygen. If at any time a crew member is doubtful whether he is receiving enough oxygen, a greater amount should be turned on. If the additional oxygen does not help, a nearby crew member should be notified.

9. If a crew member becomes unconscious from lack of oxygen:

- a. When above 25,000 feet, descend to a lower altitude, if possible.
- b. On constant-flow system open regulator to full flow. On demand system, open emergency valve on regulator.

10. If ship's oxygen supply falls below 100 lb. sq. in., descend immediately to altitude where oxygen is not needed.

## EQUIPMENT

### Constant-Flow Type

Ten G-1 oxygen cylinders are used on airplanes up to 41-11938 (5 in each wing outboard of the wheel wells). Eighteen G-1 cylinders are used on airplanes 41-23640 to 42-40217 inclusive. These are located over the wing center section and around the bottom turret well.

Both the 10 and 18-cylinder systems have, in addition, 2 type D-2 cylinders attached to the under side of the top gunner's seat. For both systems a manually operated flow regulator is at each outlet.



Constant-flow Type Mask

### Oxygen Indicators

Regulator dials marked in thousands of feet are located at each outlet. When the regulator is set at the correct flying altitude, an attached flow dial indicates amount of flow.

### Location of Controls

Oxygen Outlets—At each crew station and at right of flight deck hatch in bomb bay.

Main Shut-Off Valve—On rear spar to right of center line. Available from radio compartment over rear bomb bay.

### Demand Type

Cylinders—This system has 9 groups of cylinders with a demand regulator at each crew station: 22 oxygen cylinders of type G-1 in 8 groups and 2 cylinders of type D-2 in the 9th group. The latter, for the top gunner, is secured to the underside of his seat. The 2 D-2 cylinders are recharged from the radio operator's main line, or in an emergency, from any group. One adapter is installed on the top turret line between the two cylinders.

These groups provide at least 2 cylinders' supply for each man (a total of approximately 9 hours' supply for a crew of 10) at 30,000 feet.

Check valves are installed to prevent loss of oxygen in the event a cylinder or line is destroyed by gunfire.

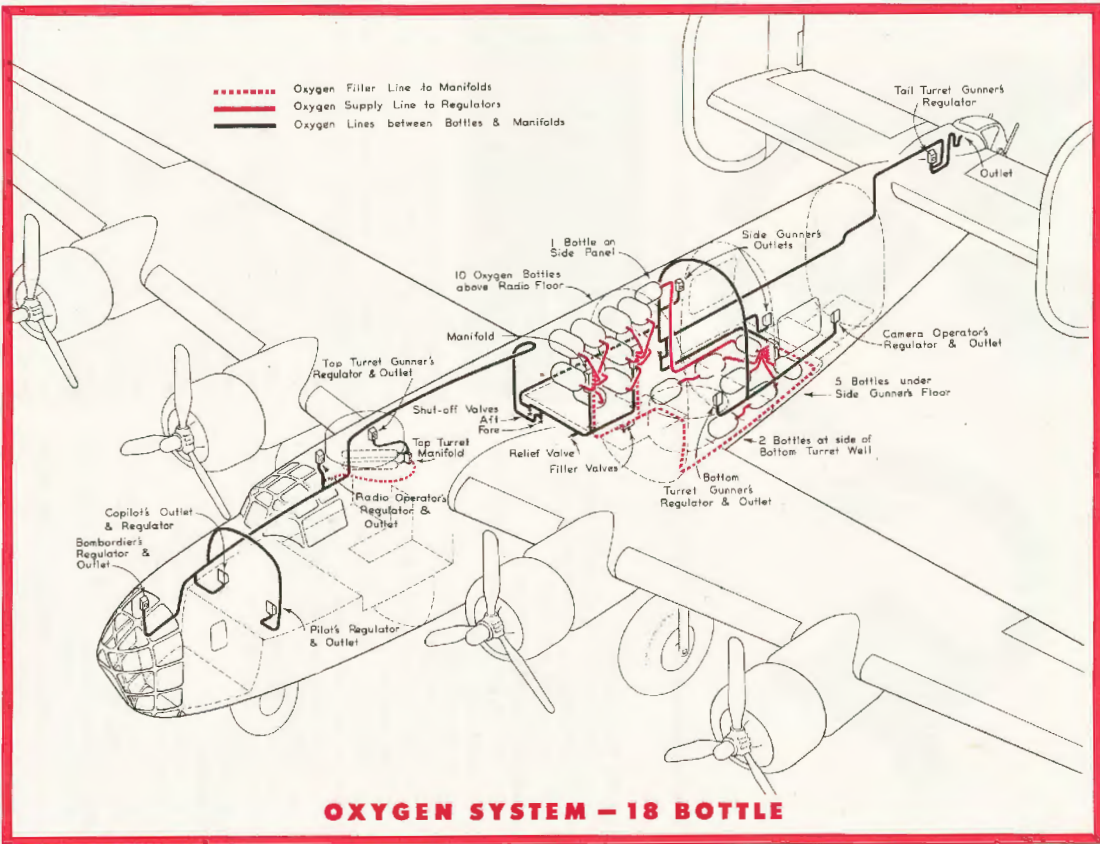

**OXYGEN SYSTEM - 18 BOTTLE**

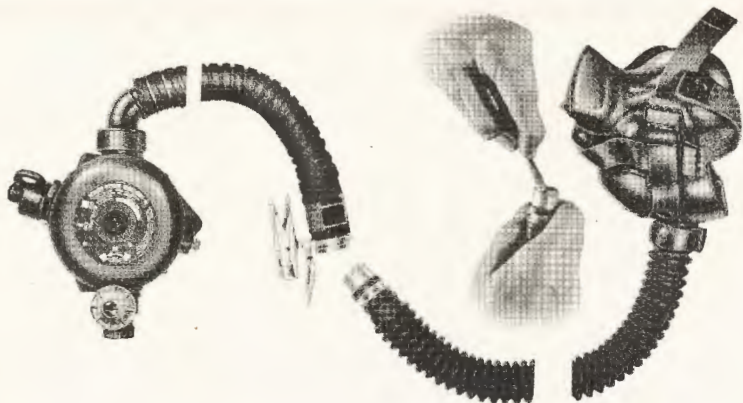

*Demand-type oxygen mask. Note the way prongs on the quick-disconnect fitting are pried apart.*

**Regulator Panel Locations**

There are now 13 outlets in place of 11 formerly used. The A-12 regulator is mounted on a panel at each crew station as follows:

**Forward fuselage compartment:**

One on the left side of the nose compartment for the nose gunner (B-24J).

One on the right side of the nose compartment for the bombardier.

One on the right side of the nose compartment for the navigator.

Two under the instrument panel, one at each end, for the pilot and copilot.

One aft and above the radio operator's table.

One on side of the top turret gunner's seat.

One on the right hand side, aft of bulkhead at Station 4.1 in the bomb bay, generally used by the engineer.

**Aft fuselage compartment:**

One on the left side between Stations 6.1 and 6.2 for bottom turret operator.

One on the left side between Stations 7.3 and 7.4 for the camera operator.

Two between Stations 7.2 and 7.3, one on each side, for side gunners.

One just forward of Station 9.2 on the right side for the rear turret gunner.



**Type K-1 Pressure Gauge**—The oxygen pressure gage indicates the pressure of the available oxygen in the supply cylinders. The dial is calibrated to indicate pounds per square inch pressure. Satisfactory operation requires a pressure from 100 lb. sq. in. minimum to 450 lb. sq. in. maximum.

**Type A-1 Oxygen Flow Indicator**—The A-1 type indicator, on the panel to the left of the pressure gage, is connected directly into the high-pressure oxygen flow. When oxygen passes through it to the gage, a red ball floats to the top of the indicator. Type A-1, however, requires several extra fittings from which leaks are more apt to occur.

**Type A-3 Oxygen Flow Indicator**—This type indicator is connected to the regulator itself. It is a pressure indicating instrument actuated by the change of pressure. It has a blinker



which opens when the person wearing the mask inhales. The A-3 indicator is in use on airplane 42-72765 and subsequent ships.

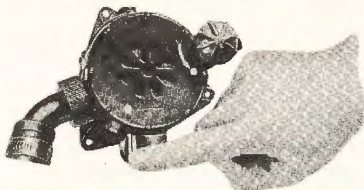

Moving the valve lever to the Auto-Mix "ON" position.

**Type A-12 Regulator**—The A-12 regulator (Pioneer Type 2850-A1) has been developed for use in high altitude flying and automatically delivers the proper mixture of air and oxygen to sustain life in the sub-stratosphere. It conserves the available supply of oxygen by furnishing only the amount of oxygen needed at any altitude. The regulator consists of the following mechanisms:

A manual valve shuts off the air when a flow of pure oxygen is required. The valve is operated by a lever on the side of the case and is marked Auto-Mix "ON" and "OFF." (Regulators of recent issue may be marked "NORMAL OXYGEN" instead of "ON," and "100% OXYGEN" instead of "OFF.")

**Note:** The "ON" ("NORMAL OXYGEN") position is used for normal flying operation.

A bypass manually operated emergency valve on the oxygen intake, at the bottom of the regulator, permits a steady flow of oxygen when needed.

A pressure reducer controls the oxygen tank pressure to about 40-60 lb. sq. in. so that the action of the demand valve is unaffected by changes of the tank pressure. A check valve on the air inlet prevents the escape of oxygen when exhaling.

**System Filler Valve**—The system filler valve is located on the outside of the airplane (left lower side) between Stations 6.1 and 6.2, and the whole system can be filled through this intake valve. It is in a closed box behind a cover plate door in the skin, free from contact with oil, grease, or foreign matter.

**Caution:** Because there is no oxygen system filler relief valve, under no circumstances should the A-12 regulator be installed on an oxygen cylinder of greater than 500 lb. sq. in. capacity.

Two adapters are installed in a stowage bag attached on the inside of the plate door. One adapter is used for charging the system with British equipment, the other when using American equipment. A card provides instructions for filling the system and for the correct use of the adapters.

**Top Turret Filler Valve**—A new shield has been installed over the filler valve of the top turret oxygen tanks. This shield is made of metal; a small plate giving filling instructions is on the end. The location of the turret guns above this valve constitutes a definite hazard unless protection against the possibility of excess oil and grease from the guns coming in contact with the valve is provided. This change took place on airplane No. 42-40786 and subsequent aircraft.

### Warning

Under no conditions allow any oil or grease to come in contact with any oxygen equipment.

### Carbon Monoxide

Some recent B-24's have a red warning light on the instrument panel to indicate the presence of carbon monoxide in the cabin. (See Exhaust Heating, Page 149.) If this warning light goes on, protection against the carbon monoxide can be gained in one of two ways: By turning off the heater, and thus removing the source of the gas, or by having all crew members don their oxygen masks, with the Auto-Mix turned to the "OFF" ("100% OXYGEN") position. Temperature or other factors may make turning off the heater inadvisable, but the use of pure oxygen is a sure safeguard against atmospheric contamination.

## VENTILATING SYSTEM

Special ventilation is provided only for the pilot, copilot, and radio operator. In early model airplanes the bombardier receives fresh air through a manually rotated slotted disc in the hand hole normally used to clean the bombsight window.

The pilot and copilot receive a direct blast of fresh air through ducts connected to the left and right pitot-static tubes respectively. Manually rotated ball and socket ventilators, at the outboard ends of the instrument panel, control fresh air supply.

The flight compartment receives fresh air through an intake duct through a "Y" to manually controlled anemostat diffusers high on the fuselage, right and left at Station 3.2.

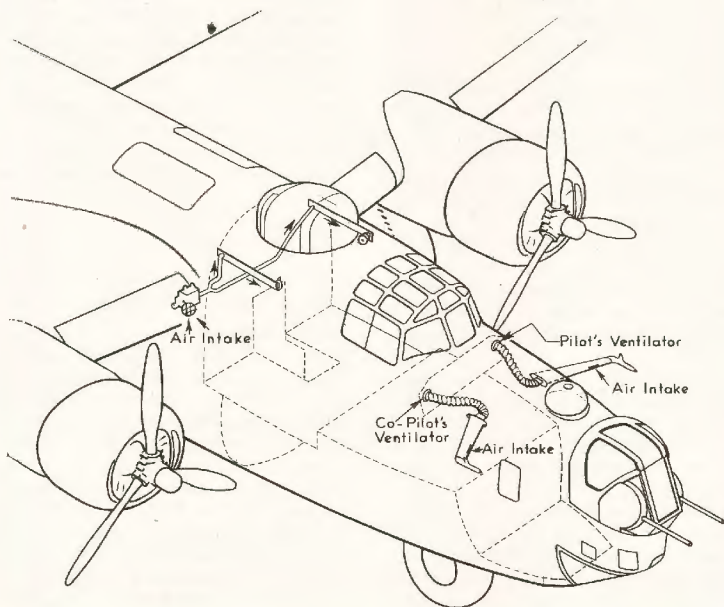

## THE C-1 AUTO PILOT

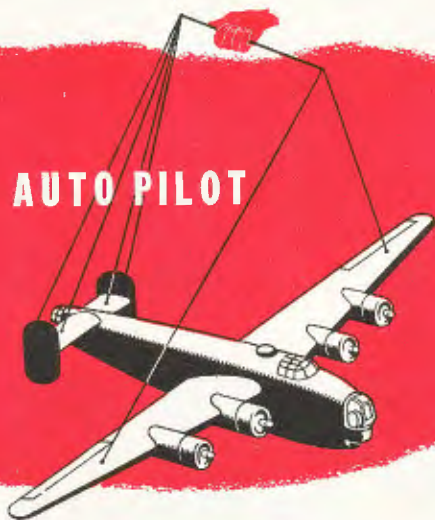

The C-1 autopilot is an electromechanical robot which automatically controls the airplane in straight and level flight, or maneuvers the airplane in response to the fingertip control of the human pilot or bombardier.

Actually, the autopilot works in much the same way as the human pilot in maintaining straight and level flight, in making corrections necessary to hold a given course and altitude, and in applying the necessary pressure on the controls to turns, banks, etc. The difference is that the autopilot acts instantaneously and with a precision that is not humanly possible.

The precision of even the most skillful human pilot is limited by his own reaction time, i.e., the interval between his perception of a certain condition and his action to correct or control it. Reaction time itself is governed by such human fallibilities as fatigue, inability to detect errors the instant they occur, errors in judgment and muscle coordination.

The autopilot, on the other hand, detects flight deviations the instant they occur, and just as instantaneously operates the controls to

correct the deviation. Properly adjusted, the autopilot will neither overcontrol nor undercontrol the airplane, but will keep it flying straight and level with all 3 control surfaces operating in full coordination.

### How It Works

The C-1 autopilot consists of various separate units electrically interconnected to operate as a system. The operation of these units is explained in detail in AN-11-60AA-1. A general over-all understanding of their functions and relation to each other can be acquired by studying the accompanying illustration.

Assume that the airplane in the illustration is flying straight and level and that the autopilot is at work.

Suddenly turbulent air turns the airplane away from its established heading. The gyro-operated directional stabilizer (1) in the bombardier's compartment detects this deviation and moves the directional panel (4) to one side or the other, depending upon the direction of the deviation.

RESTRICTED

The directional panel contains 2 electrical devices, the banking pot (5) and the rudder pick-up pot (6), which send signals to the aileron and rudder section of the amplifier (16) whenever the directional panel is operated. These signals are amplified and converted (by means of magnetic switches or relays) into electrical impulses which cause the aileron and rudder Servo units (15 and 18) to operate the ailerons and rudder of the airplane in the proper direction and amount to turn the airplane back to its original heading.

Similarly, if the nose of the airplane drops, the vertical flight gyro (10) detects the vertical

RESTRICTED

deviation and operates the elevator pick-up pot (11) which sends an electrical signal to the elevator section of the amplifier. The signal is amplified and relayed in the form of electrical impulses to the elevator Servo unit (19) which in turn raises the elevators the proper amount to bring the airplane to level flight.

If one wing drops appreciably, the vertical flight gyro operates the aileron pick-up pot (12), the skid pot (13), and the up-elevator pot (14). The signals caused by the operation of these units are transmitted to their respective (aileron, rudder, and elevator) sections of the amplifier. The resulting impulses to the

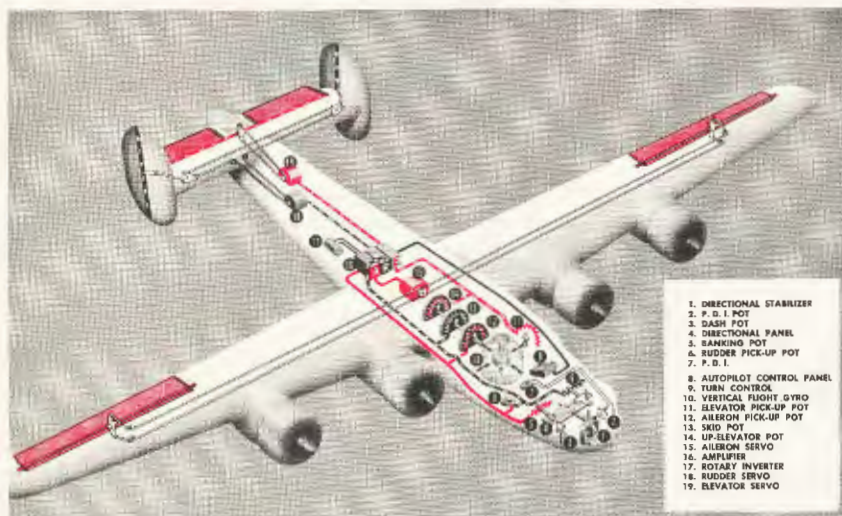

aileron, rudder, and elevator Servo units cause each of these units to operate its respective control surface just enough to bank and turn the airplane back to a level-flight attitude.

When the human pilot wishes to make a turn, he merely sets the turn control knob (9) at the degree of bank and in the direction of turn desired. This control sends signals, through the aileron and rudder sections of the amplifier, to the aileron and rudder Servo units which operate ailerons and rudder in the proper manner to execute a perfectly coordinated (non-slipping, non-skidding) turn. As the airplane banks, the vertical flight gyro operates the aileron, skid, and up-elevator pots (12, 13, 14). The resulting signals from the aileron and skid pots cancel the signals to the aileron and rudder Servo units to streamline these controls during the turn.

The signals from the up-elevator pot cause the elevators to rise just enough to maintain altitude. When the desired turn is completed, the pilot turns the turn control back to zero

and the airplane levels off on its new course. A switch in the turn control energizes the directional arm lock on the stabilizer, which prevents the stabilizer from interfering with the turn by performing its normal direction-correcting function.

The autopilot control panel (8) provides the pilot with fingertip controls by which he can conveniently engage or disengage the system, adjust the alertness or speed of its responses to flight deviations, or trim the system for varying load and flight conditions.

The pilot direction indicator, or PDI (7), is a remote indicating device operated by the PDI pot (2). When the autopilot is used, the PDI indicates to the pilot when the system and airplane are properly trimmed. Once the autopilot is engaged, with PDI centered, the autopilot makes the corrections automatically.

The rotary inverter (17) is a motor-generator unit which converts direct current from the airplane's battery into 105-cycle alternating current for operation of the autopilot.

## HOW TO OPERATE THE C-1 AUTOPILOT

### *Before Takeoff*

1. Set all pointers on the control panel in the up position.



2. Make sure that all switches on the control panel are in the "OFF" position.

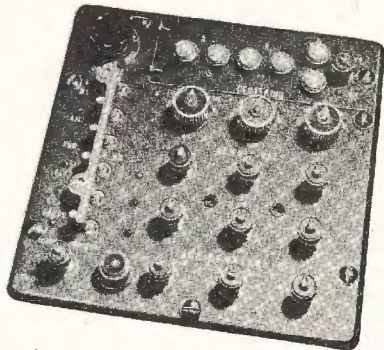

## After Takeoff

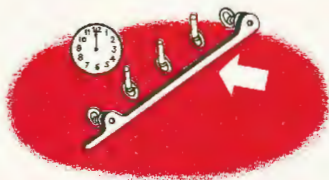

1. Turn on the master switch.



2. Five minutes later, turn on PDI switch (and Servo switch, if separate).



3. Ten minutes after turning on the master switch, trim the plane for level flight at cruising speed by reference to flight instruments.



4. Have the bombardier disengage the autopilot clutch, center PDI and lock it in place by depressing the directional control lock. The PDI is held centered until the pilot has completed the engaging procedure. Then the autopilot clutch is re-engaged, and the directional arm lock released.

Alternate Method: The pilot centers PDI by turning the airplane in direction of the PDI needle. Then resume straight and level flight.

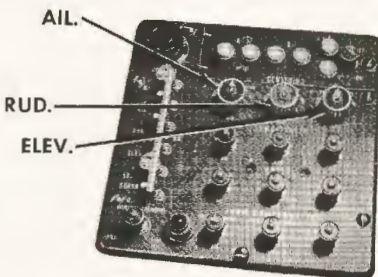

5. Engage the autopilot. Put out aileron tell-tale lights with the aileron centering knob, then throw on the aileron engaging switch. Repeat the operation for rudder, then for elevator.

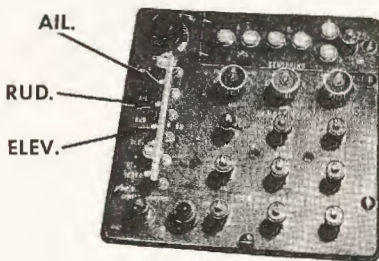

6. Make final autopilot trim corrections. If necessary, use centering knobs to level wings and center PDI.

### Caution:

**NEVER ADJUST MECHANICAL TRIM TABS WHILE THE AUTOPILOT IS ENGAGED**

## FLIGHT ADJUSTMENTS AND OPERATION

After the C-1 autopilot is in operation, carefully analyze the action of the airplane to make sure all adjustments have been properly made for smooth, accurate flight control.

When both **tell-tale** lights in any axis are extinguished, it is an indication the autopilot is ready for engaging in that axis.

Before engaging, each **centering knob** is used to adjust the autopilot control reference point to the straight and level flight position of the corresponding control surface. After engaging, centering knobs are used to make small attitude adjustments.



**Sensitivity** is comparable to a human pilot's reaction time. With sensitivity set high, the autopilot responds quickly to apply a correction for even the slightest deviation. If sensitivity is set low, flight deviations must be relatively large before the autopilot will apply its corrective action.

**Ratio** is the amount of control surface movement applied by the autopilot in correcting a given deviation. It governs the speed of the airplane's response to corrective autopilot actions. Proper ratio adjustment depends on airspeed.



If ratio is too high, the autopilot will overcontrol the airplane and produce a ship hunt; if ratio is too low, the autopilot will undercontrol and flight corrections will be too slow. After ratio adjustments have been made, centering may require readjustment.

To adjust **turn compensation**, have bombardier disengage autopilot clutch and move engaging knob to extreme right or extreme left. Airplane should bank 18° as indicated by artificial horizon. If it does not, adjust aileron compensation (bank trimmer) to attain 18° bank. Then, if turn is not coordinated, adjust rudder compensation (skid trimmer) to center inclinometer ball. Do not use aileron or rudder compensation knobs to adjust coordination of turn control turns.

### *Emergency Use of Autopilot*

#### REMEMBER THE ROLE THAT THE AUTOPILOT CAN PLAY IN EMERGENCIES

1. If the control cables are damaged or severed between the pilot's compartment and the Servo units in the tail, the autopilot can bridge the gap. There have been many instances where the autopilot has

been used thus to fly an airplane with damaged controls.

2. If the autopilot has been set up for level flight, it can be used to hold the airplane straight and level while abandoning ship.

RESTRICTED

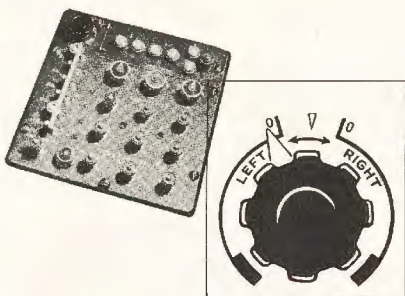

The **turn control** is used by the pilot to turn the airplane while flying under automatic control. To adjust turn control, first make sure turn compensation adjustments have been properly made, then set turn control pointer at beginning of trip-lined area on dial. Airplane

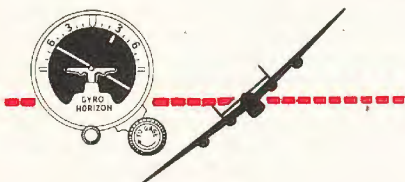

should bank 30°, as indicated by artificial horizon. If it doesn't, remove cap from aileron trimmer and adjust trimmer until a 30° bank is attained. Then, if turn is not coordinated (inclinometer ball not centered), adjust rudder trimmer to center ball. Make final adjustments with both trimmers and replace caps. Set turn control at zero to resume straight and level flight; then re-center.

**Never operate the Turn Control without first making sure the PDI is centered**

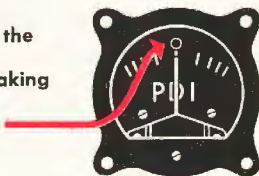

RESTRICTED

The **turn control transfer** has no effect unless the installation includes a remote turn control.

The **dashpot** on the stabilizer regulates the amount of rudder kick applied by the autopilot to correct rapid deviations in the turn axis. If a rudder hunt develops which cannot be eliminated by adjustment of rudder ratio or sensitivity, the dashpot may require adjustment.

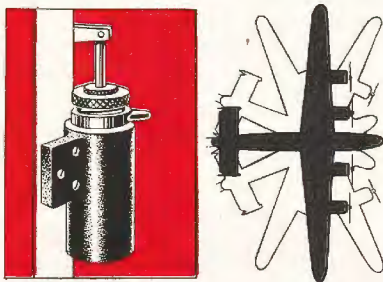

This is accomplished by loosening the locknut on the dashpot, turning the knurled ring up or down until hunting ceases, then tightening the locknut.

**Cold Weather Operation**—When temperatures are between  $-12^{\circ}$  and  $0^{\circ}\text{C}$  ( $10^{\circ}$  and  $32^{\circ}\text{F}$ ) autopilot units must be run for 30 minutes before engaging. If accurate flight control is desired immediately after takeoff, perform the autopilot warm-up before takeoff by turning on the master switch during the engine run-up—but make sure autopilot is off during takeoff. If warm-up is performed during flight, allow 30 minutes after turning on master switch before engaging. When temperatures are below  $-12^{\circ}\text{C}$  ( $10^{\circ}\text{F}$ ) units must be preheated for one hour before takeoff. Use special heating covers or blankets with heating tubes.

RESTRICTED



## FLYING THE PDI MANUALLY

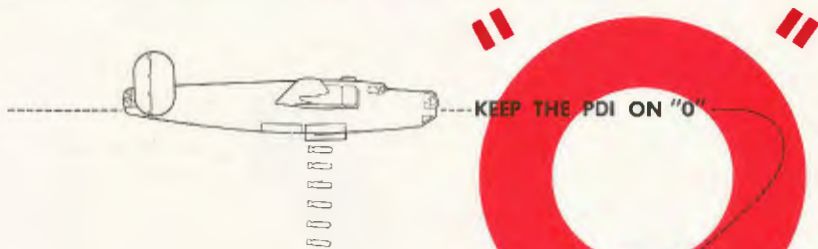

### *Before Takeoff*

1. Check with bombardier for proper position of PDI needle for a left turn, right turn, and neutral or "0" position.

2. When bombardier's PDI is left, pilot's PDI is right, and vice versa.

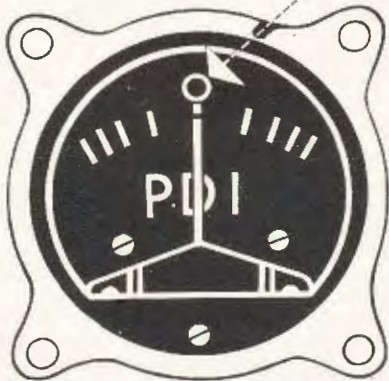

### *On the Bombing Run*

Normally bombing will be done while using the autopilot. However, if the autopilot is not functioning the pilot may use the PDI.

1. To center the PDI needle, turn the airplane in the direction of the needle.

2. At the beginning of the bombing run, the pilot usually can expect maximum PDI corrections. Avoid tendency to overcorrect by refraining from leading the needle.

3. No matter how slight the deviation of the PDI needle from "0," the needle must be returned to "0" immediately.

4. Set turns must be coordinated aileron and rudder turns, in order to make the desired degree of turn more rapidly and to avoid any excessive sliding of the bombsight lateral bubble and induced precession of the gyro.

5. To avoid tumbling of the bombsight gyro, banks must never exceed 18°.

6. Keep PDI on "0" until bombardier calls "Bombs away."

RESTRICTED

## THE FORMATION STICK

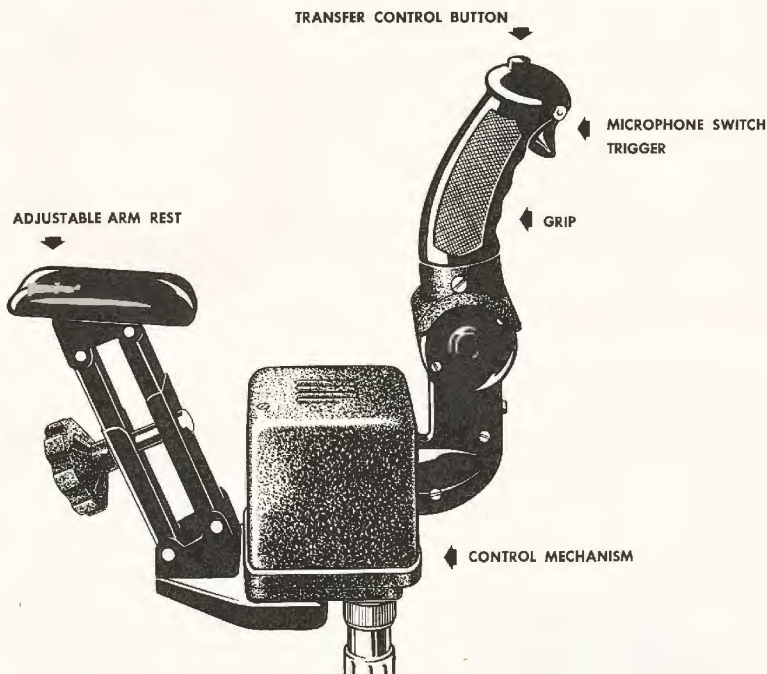

The formation stick is a miniature control stick, working through the autopilot, that enables you and your copilot to maneuver your airplane quickly and with a minimum of effort. You use the formation stick as you would the control stick of a primary trainer—forward and back for descents and climbs, sideways for banks. Sideways movement of the stick controls both ailerons and rudders in coordination, eliminating the need for separate rudder control. Movement of the stick electrically actuates the servo units of the autopilot, which in turn move the control surfaces.

There are two sticks, one on the pilot's left, the other on the copilot's right. Only one stick is engaged at a time; transfer switches shift control of the airplane from the pilot's stick to the copilot's, and vice versa. Push-to-talk trigger switches on both formation sticks control the radio microphones.

There is a four-position function selector that determines to what extent the formation stick will control the airplane. These positions are:

1. "OFF"—In this position the autopilot operates normally and flies the airplane, the stick having no control.

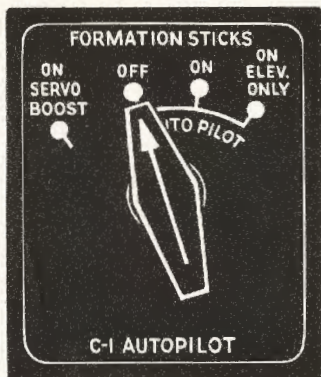

2. "ON SERVO BOOST"—The stick is in direct control of the autopilot servos and you must use it as if it were mechanically linked to the surface controls. Use this position when you want quick maneuvering, as in a wing position of a tight formation.

3. "ON ELEV. ONLY"—The stick provides only vertical control of the airplane, the autopilot controlling ailerons and rudder. The bombardier makes turns with the bombsight autopilot attachment, or the pilot can use the autopilot turn control. Use this position when the bombardier has control of the airplane.

4. "ON"—The autopilot is flying the airplane, with the stick working like the autopilot turn control, except that it provides vertical as well as bank control. Use this position when leading a formation, in a wing position of a loose formation, or in other situations where little maneuvering is required.

#### How to Use

1. Before takeoff, check both autopilot master switch and the formation stick function selector in the "OFF" position.

2. In flight, when ready to use the formation stick, set up the autopilot in the normal manner.

3. Engage the formation stick by turning function selector to "ON," "ON SERVO

BOOST," or "ON ELEV. ONLY," depending upon the type of operation desired.

#### To Transfer Control

To transfer control from pilot stick to copilot stick, push the button on top of the copilot stick. To regain control, the pilot pushes his button. If both buttons are pressed at the same time, the pilot gets control. When the formation stick is first engaged, the pilot has control automatically.

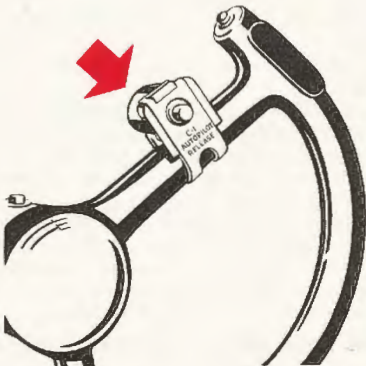

#### To Disengage Stick

An autopilot release switch on the wheel of each regular control column permits either pilot or copilot to return the airplane to manual control. Momentary pressure on either switch immediately disengages all three autopilot servos.

To re-engage the formation stick after the release switch has been used, turn off all autopilot switches, retrim the airplane, and then engage autopilot and formation stick in the normal manner.

However, if the release switch is pressed accidentally and the formation stick has not been moved while the autopilot is disengaged, you can re-engage the formation stick by snapping the autopilot switch off and then right on again, turning the other autopilot switches on without the usual adjustments. Do not use this method unless you are sure the formation stick has not been moved while the autopilot was off.

RESTRICTED

## *Pilot's Operating Instructions*

### **SUGGESTED ENGAGING PROCEDURE FOR LEAD AIRPLANE**

1. After take-off, check that the function selector is in the "OFF" position.
2. Turn the tell-tale light shutter switch on.
3. Center the turn control knob.
4. Place the turn control transfer knob to "Pilot" position.
5. Turn on C-1 master switch.
6. Manually trim airplane for desired flight attitude.
7. Set all C-1 control knobs to "pointers up" position.

Note: All controls must be previously adjusted in flight by competent personnel for best performance under expected conditions and this adjustment indexed by fixing the pointers in the "Up" position.

8. Turn on PDI and servo switch 10 minutes after turning on master switch.
9. Have Bombardier disengage autopilot clutch arm to center PDI; and press down on directional arm lock to keep PDI centered.

### **SUGGESTED ENGAGING PROCEDURE FOR WING AIRPLANES**

1. After take-off, turn the function selector to the "ON SERVO BOOST" position.
2. Turn the tell-tale light shutter switch on.
3. Center turn control knob.
4. Place turn control transfer knob in "Pilot" position.
5. Have bombardier disengage autopilot clutch, move clutch arm to center PDI, and press down on Directional Arm Lock to keep the PDI centered.
6. Turn on C-1 master switch. (This will lock the directional arm.)
7. Have bombardier re-engage autopilot clutch and remove hand from directional arm lock.
8. Manually trim airplane for desired flight attitude.
9. Set all C-1 control knobs to "Pointers Up" position.

Note: All controls must be previously adjusted in flight by competent personnel for best performance under expected conditions and

10. Put out aileron tell-tale lights by adjusting aileron centering knob.
11. Snap aileron switch on.
12. Check gyro horizon and readjust aileron centering to level wings.
13. Put out rudder tell-tale lights with rudder centering knob.
14. Snap rudder switch on.
15. Have Bombardier re-engage autopilot clutch and release directional arm lock.
16. Readjust rudder centering knob to center PDI if necessary.
17. Put out elevator telltale lights with elevator centering knob.
18. Snap elevator switch on.
19. Readjust elevator centering if necessary.
20. Turn function selector to "ON" position. The formation sticks may now be used to make coordinated turns up to approximately 25° of bank and also to control the elevator.

this adjustment indexed by fixing the pointers in the "Up" position.

10. Turn on PDI and servo switch, not less than one minute after the master switch was engaged. Note: If Function Selector is left in the "ON SERVO BOOST" position, it is not necessary to wait ten minutes for the gyros to erect.
11. Put out aileron tell-tale lights by adjusting aileron centering knob.
12. Snap on aileron switch.
13. Use formation stick to maintain aileron control as soon as aileron switch is snapped on.
14. Put out rudder tell-tale lights by adjusting rudder centering knob.
15. Snap on rudder switch.
16. Use formation stick for both aileron and rudder control after rudder switch is snapped on.
17. Put out elevator tell-tale lights by adjusting elevator centering knob.
18. Snap on elevator switch. The formation

stick can now be used to control the flight of the airplane in all axis.

The function selector knob may be turned to any one of the four positions: "ON SERVO BOOST," "OFF," "ON," or "ELEV. ONLY" to give the desired control.

#### "ON SERVO BOOST" Position

This selector setting is to be used when flying a wing position in a tight formation or whenever quick maneuvering is desired.

To maneuver the airplane, move the stick in the same manner as a manual control stick would be moved.

The three centering knobs may be used to trim the airplane for the desired attitude with the stick in the normal center position.

Do not adjust the turn control trimmers during "ON SERVO BOOST" operation.

Aileron and rudder ratio may be adjusted to coordinate the controls for going into a bank or coming out of one but will have no effect while the controls are streamlined in the bank. Therefore, some slipping will be noticed in steep continuous banks.

Do not attempt to adjust the dashpot during "ON SERVO BOOST" operation since the dashpot has no effect on the operation of the autopilot with the directional arm lock engaged.

#### "OFF" Position

Whenever it is desired to fly an autopilot without using the sticks, turn the selector to "OFF."

#### "ON" Position

Use this selector position when leading a formation, in a wing position of a loose formation, or when very little maneuvering is desired, such as for course corrections on cross-country flights. In the "ON" position the stick is handled in the following manner:

1. For straight and level flights, leave the stick in center, and the autopilot will automatically maintain straight and level flight.

2. To climb or glide, move the stick backward or forward a distance sufficient to produce the desired change in attitude, and hold it there until ready to return to level flight. Release the stick or return it to center to return the airplane to level flight.

3. For a turn, move the stick from center in the desired direction a distance sufficient to produce the desired bank and turn. Maximum bank obtainable is approximately 25 degrees. Hold the stick in that position until the turn is complete. Return the stick to center to come out of the turn.

Streamlining of controls and application of up-elevator in the turn are automatically accomplished by the vertical flight gyro of the autopilot. More or less elevator may be applied by moving the stick forward or backward. Coordination of turns may be adjusted with the turn control trimmers.

Sensitivity and ratio adjustments may be made for flight conditions. If there is a tendency of the airplane to hunt in the turn axis, the dashpot may require adjusting.

Centering adjustments of the aileron, rudder, and elevator centering knobs may be used to adjust the attitude of the airplane. Make adjustments only with the stick centered.

#### "ON ELEV. ONLY" Position

Use this position when the bombardier has control. Hold the stick back to climb, in a forward position to dive. The rate of climb or dive will be governed by the distance the stick moved from center. Movement of the stick to right or left will have no effect. Turns may be made by the directional panel (bombardier) or the autopilot turn control.

#### Changing Function Selector Position

Always hold the airplane level while changing the selector from one position to another.

Make sure that the PDI is on zero before changing from any position to "ON SERVO BOOST." This is necessary to insure that the erecting cut-out switch in the directional panel is not closed when the directional arm is locked.

The autopilot master switch must have been on for at least 10 minutes before the function selector is moved from the "ON SERVO BOOST" position in order to give the autopilot gyros time to erect. If banks have exceeded 40 degrees the autopilot gyros may have tumbled and the function selector should not be moved from "ON SERVO BOOST" position for at least 10 minutes after the last steep bank.

## TIPS ON USING FORMATION STICK

1. Make sure PDI is on zero before turning function selector to "ON SERVO BOOST" position. Otherwise an abrupt turn may result.

2. Remember that with the selector in "ON SERVO BOOST" position the autopilot has no control. Use the formation stick as if it were a manual control.

3. Don't use the autopilot turn control when the selector is in "ON SERVO BOOST" position.

4. Don't exceed 40° banks; the autopilot gyro may tumble. A tumbled gyro will not affect the flying characteristics while the selector is in "ON SERVO BOOST" position. However, when the function selector is moved to any other position a sudden maneuver results. If you do exceed a 40° bank fly the airplane straight and level for about 10 minutes to allow

the gyro to right itself before turning the function selector from "ON SERVO BOOST" position.

5. Don't use the formation stick as a hand-hold or hat-rack. You can break it.

6. Don't use the formation stick for landing unless your manual controls fail. The stick doesn't provide separate aileron and rudder control, and provides less movement of control surfaces than manual operation.

7. Since the formation stick works through the autopilot, remember to observe the same precautions when using it as you do when using the autopilot alone.

8. Don't expect the formation stick to work properly unless the autopilot is functioning as it should. Use the autopilot ground checklist prior to flight.

## PILOT'S GROUND CHECKLIST FOR FORMATION STICK

1. Complete the autopilot ground check, with the exception of the last step, leaving the autopilot engaged.

2. Set the formation stick function selector at "ON."

3. Move pilot's stick to the extreme right. The control wheel should turn clockwise, and the right rudder pedal should move forward. Make same check to the left.

With the stick held off center, have the directional arm lock on the directional stabilizer checked, to make sure that the arm is held securely. Then release the stick and see that it returns to center automatically, returning control wheel and rudder pedals to center as it moves.

With the formation stick in center, make sure the directional arm lock is released.

4. Move the formation stick forward, then back. The control column should follow the stick movement, and when stick is released both stick and control column should return to center automatically.

5. Press transfer button on top of copilot's stick, to give this stick control. Then repeat the above check. Transfer control back to pilot's stick.

6. Move the function selector to "ON SERVO BOOST." Then move the stick to each side and forward and back, making sure that all controls move in the proper directions. The control response should be the same as with the function selector at "ON," except that the aileron and rudder controls may not move as far.

7. Move function selector to "ON ELEV. BOOST." Then move pilot's stick backward and forward to check operation of elevator control. The control column should move only about one-third as far as it does with the function selector in the "ON" position. Movement of the stick sideways should not affect the ailerons or rudders.

8. Press the transfer button on the copilot's stick and move the stick to make sure that this stick now has control.

9. Press the autopilot release switch on the copilot's control wheel and check operations of controls to make sure they operate freely and autopilot is disengaged.

10. Snap the autopilot master switch "OFF," then immediately back "ON," and re-engage the remaining autopilot switches.

11. Move pilot's stick to make sure it has regained control.

12. Press autopilot's release switch on pilot's

control wheel and check operation of controls to make sure they operate freely and autopilot is disengaged.

13. Check operation of pilot's and copilot's microphone switches. To check, turn radio control switch to "INTER-COM" position. Then squeeze trigger on each formation stick, while using microphone and listening on headset.

14. Move function selector to "OFF," and turn off autopilot master switch.

## PILOT'S GROUND CHECKLIST FOR THE C-1 AUTOPILOT

1. Center turn control.
2. Turn on C-1 master switch bar.
3. Set control transfer knob at "PILOT."
4. Set tell-tale shutter switch "ON."
5. Set all adjustment knobs to pointers-up position, making sure pointers are not loose.
6. Tell bombardier to center PDI.
7. Turn on Servo PDI switch.
8. Operate controls through extreme range several times, observing that tell-tale lights flicker and go out as streamline position is reached from either direction.
9. Turn on aileron, rudder, and elevator switches.
10. Turn aileron centering knob clockwise,

then counter-clockwise, observing that wheel turns to the right and then to the left.

11. Repeat Item 10 for rudder and elevator, observing action.

12. Have bombardier move directional arm for full right turn, then to left, observing to see if aileron and rudder move in proper direction.

13. Have bombardier center PDI and engage secondary clutch.

14. Rotate turn control knob for right and left turns, observing aileron and rudder controls for proper movement.

15. If all checks are satisfactory, turn the C-1 master switch bar "OFF."

RESTRICTED

## THE GYRO FLUX GATE COMPASS

The gyro flux gate compass, remotely located in the wing or tail of the airplane, converts the earth's magnetic forces into electrical impulses to produce precise directional readings that can be duplicated on instruments at all desired points in the airplane.

Unlike the magnetic needle, it will not go off its reading in a dive, overshoot in a turn, hang in rough weather, or, go haywire in polar regions.

### Development of the Flux Gate

The gyro flux gate compass was developed to fill the need for an accurate compass for long-range navigation. The presence of so many magnetic materials (armor, electrical circuits, etc.) in the navigator's compartment made it almost impossible to find a desirable location for the direct-reading magnetic compass.

To eliminate this difficulty, it became necessary to place the magnetic element of the navigator's compass outside the compartment, i.e., to use a remote indicating compass. The unit which is remotely located is called the transmitter. The unit used by the navigator is the master indicator. For the benefit of the pilot and such other crew members as may have needs for compass readings, auxiliary instruments called repeater indicators may be installed in other parts of the airplane.

### Units of the Flux Gate Compass

The gyro flux gate compass consists of 3 units which are analogous to the brain, heart, and muscles of the human body. The transmitter, located in the wing or tail of the airplane, is the brain of the instrument. The amplifier is the source of power for the compass and corresponds to the human heart. The master indicator does the work of turning a pointer and performs a function similar to that of the muscles in the human body.

1. **The Brain.**—Inside the remotely placed transmitter there is a magnetic sensitive element called the flux gate which picks up the

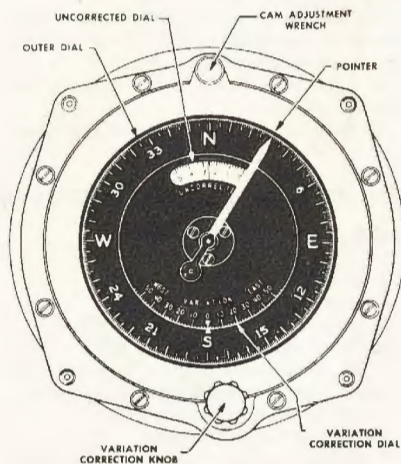

direction signal by induction and transmits it to the master indicator. This element consists of 3 small coils, arranged in a triangle and held on a horizontal plane by a gyro. Each coil has a special soft iron core, and consists of a primary (or excitation) winding, and a secondary winding from which the signal is obtained.

Because each leg of the flux gate is at a different angle to the earth's magnetic field, and the induced voltage is relative to the angle, each leg produces a different voltage. When the angular relationship between the flux gate and the earth's magnetic field is changed, there is a relative change in the voltages in the 3 legs of the secondary. These voltages are the motivating force for the gyro flux gate compass master indicator which provides indications of the exact position of the flux gate in relation to the earth's magnetic field.

Each coil is a direction sensitive element; but one alone would provide an ambiguous reading because it could tell north from east, for instance, but not north from south. Therefore, it



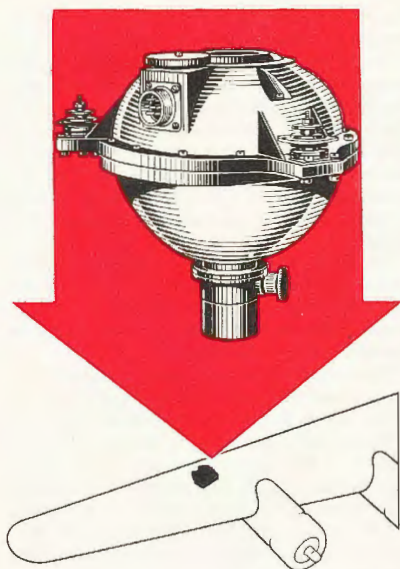

is necessary to employ 3 coils and combine their output to give the direction signal.

2. **The Heart.**—The amplifier furnishes the various excitation voltages at the proper frequency to the transmitter and master indicator. It amplifies the autosyn signal which controls the master indicator and serves as a junction box for the whole compass system.

Power for the amplifier comes from the airplane's inverter and is converted to usable forms for other units. The input of the amplifier is 400-cycle alternating current and various voltages may be used depending upon the source available.

3. **The Muscle.**—The master indicator is the muscle of the system because it furnishes the

mechanical power to drive the pointer on the main instrument dial. The pointer is driven through a cam mechanism which automatically corrects the reading for compass deviation so that a corrected indication is obtained on all headings. The shaft of the pointer is geared to another small transmitting unit in the master indicator which will operate as many as six repeat indicators at other locations.

The amplifier, master indicators and repeaters all are unaffected by local magnetic disturbances.

#### How to Operate the Compass

1. Leave the toggle switch on the flux gate amplifier "ON" at all times so that the compass will start as soon as the airplane's inverter is turned on.

2. Leave the caging switch in the "UNCAGE" position at all times except when running through the caging cycle.

3. About 5 minutes after starting engines, throw caging switch to "CAGE" position. Leave it there about 30 seconds and then throw to "UNCAGE" again.

4. With the new push button-type caging switch, depress it for a few seconds until a red signal light goes on. Then release the switch and the caging cycle is automatically completed, at which time the red light goes out.

5. Set in the local variation on the master indicator if you wish the pointer to read true heading.

6. If at any time during flight the compass indications lead you to suspect that the gyro is off vertical, run through the caging cycle when the airplane is in normal flight attitude, especially when leveling off after climb.

**Note:** For further details concerning functions, operation and flight instructions, see Technical Order No. 05-15-27.

RESTRICTED

## RADIO EQUIPMENT

### Command Receiver Equipment

The receiver equipment consists of 3 individual 6-tube superheterodyne receivers BC 453-A, BC 454-A, and BC 455-A, which cover the following frequency bands: (1) 3 to 6 Mc (3000-6000 Kc); (2) 190 to 550 Kc; (3) 6 to 9.1 Mc (6000-9100 Kc).

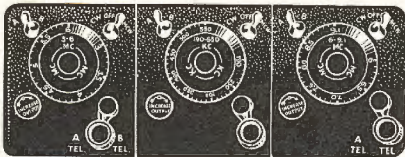

Command receivers are generally operated by the pilot for airplane-to-ground communication. The receiver control head unit BC 450-A is located within easy reach of both the pilot and copilot. In the upper left hand corner of this control head unit there is a channel selector switch with positions "A" and "B." When this switch is in position "A," the person can hear the output of the receiver in any of the interphone boxes or in any Tel A jack, but if the channel selector switch is in position "B" the output from that receiver can only be heard by plugging the earphones into the Tel B jack on the bottom of control head unit or on the Tel B jack in receivers themselves.

Considerable care should be taken in the antenna alignment of each individual receiver, and the antenna alignment control on the lower left hand corner of the receiver itself should be adjusted for maximum signal strength at the high-frequency end of the dial.

### Command Transmitter Equipment

Command transmitter equipment consists of 2 transmitters of set frequency ranges and does

not require changing of coils. All equipment is remotely controlled from the flight deck.

The 2 transmitters are the BC 457-A with a range of from 3 to 5.3 Mc (3000-5300 Kc), and the BC 458-A with a range of from 5.3 to 7 Mc. The modulator unit BC 456-A and dynamotor DM-33A supply the high-voltage DC and modulating power to either transmitter. The antenna relay unit BC 442-A is used for switching a single antenna between the receivers and transmitters.

The peak power output of either transmitter under optimum antenna loading conditions exceeds 40 watts for 28-volt input to the equipment (although this condition is not likely to be obtained in the airplane).

The transmitter is not crystal controlled, but is a master oscillator type exciting a pair of beam tetrode power amplifier tubes in parallel.

There are 3 controls on the front of the transmitter: 1. The frequency knob in the lower right corner marked "Frequency." When properly calibrated the frequency can be set within 3% of the indicated dial frequency; 2. The tuning inductance located in the upper right section marked "Ant. Inductance"; 3. The antenna coupling control located in the middle left side marked "Ant. Coupling."

**Important:** Transmitters must be tuned up with the emission switch of the radio control box 451-A in the "CW" position, and must not be readjusted in any way after switching to "VOICE" or "TONE."

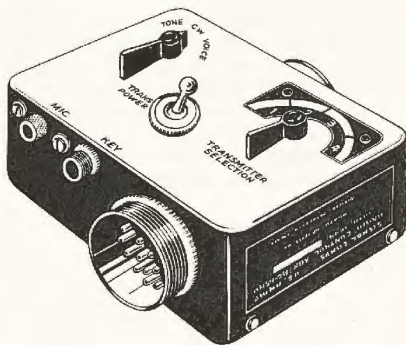

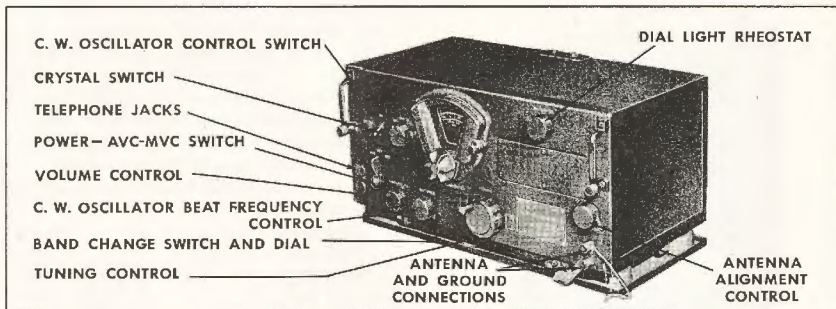

LIAISON RADIO RECEIVER

### Liaison Receiver

The liaison receiver consists of an 8-tube superheterodyne communications receiver BC 348-C or BC348-H. The BC348-H has 7 frequency bands covering frequencies from 200 to 500 Kc and from 1.5 to 18 Mc. Be familiar with the following controls on the receiver:

1. The antenna alignment knob should always be tuned for maximum background noise in the headset.

2. The crystal switch on the "IN" position cuts out interference and increases selectivity but decreases the sensitivity of the signal.

3. The CW oscillator switch is turned to "ON" position for code signals and to "OFF" position for voice reception.

4. MVC means that the receiver is in manual volume control and that the signal will fade in and out; whereas AVC means that the receiver is in automatic volume control and that the signal will not fade. MVC is used generally for code and AVC for voice.

5. The beat frequency knob can be used on CW reception as a trimmer and tone-variation control. It has little effect on voice reception.

Most pilots are familiar with frequency in terms of kilocycles but much of the aircraft equipment is calibrated in terms of megacycles. To change Mc to Kc, add three zeros to the megacycle reading (3 Mc equals 3000 Kc).

The liaison receiver is the radio operator's receiver used by him in conjunction with the

liaison transmitter to carry on communication from the airplane. The receiver can be used to calibrate the liaison transmitter in flight when flight conditions prevent the use of the frequency meter.

### Liaison Transmitter

The liaison transmitter equipment consists of one medium-range transmitter, a dynamotor, antenna, antenna variometer, and 7 tuning units which lock into the bottom of the transmitter. All of the equipment is under the control of the radio operator, though the pilot and copilot can operate the transmitter remotely through their interphone switch boxes.

The transmitter is a master oscillator, power amplifier type with a class B modulator. Since it is not crystal-controlled, its frequency must be carefully calibrated against some stable frequency measuring device such as the frequency meter.

### FREQUENCY METER

The frequency meters commonly used in large bombers provide a means of accurately calibrating a transmitter or receiver on any given frequency between 125 Kc and 20,000 Kc.

Most calibration charts on the front of aircraft transmitters cannot be relied upon to be accurate because of vibration and many other factors, and if the radio operator uses these charts as his only means of setting the fre-

RESTRICTED

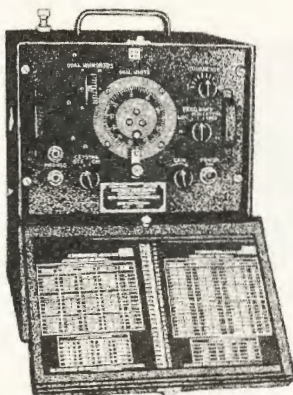

FREQUENCY METER SET SCR-211-D

quency of the transmitters, often he will be from 1 to 50 Kc off of his desired frequency.

The frequency meter is a crystal-controlled precision instrument which can be relied upon to be accurate within  $\frac{1}{2}$  of 1 Kc over its entire frequency range; therefore the radio operator should use the frequency meter with practically every transmitter tuning. It is a 3-tube receiver-transmitter combination which is capable of receiving a radio signal on a given frequency and at the same time transmitting a signal on that frequency.

The circuit employed in the frequency meter consists of a self-excited heterodyne oscillator and a crystal oscillator. The broad frequency range is obtained by varying the self-excited oscillator, and the frequency accuracy is obtained by beating the self-excited oscillator against the highly accurate crystal oscillator. Its power source consists of self-contained A and B batteries.

## VHF EQUIPMENT

The SCR 522 VHF (very high frequency) transmitter-receiver provides 2-way communication between aircraft and ground stations. Provision is made for voice communication and continuous audio tone modulation.

The pilot and copilot control the VHF equipment by means of the radio control box on the right side of the pedestal. The set operates on any one of 4 pre-set crystal controlled frequency channels between 100 and 156 Mc. Line-of-sight communication is normally necessary for satisfactory operation. Assuming communication is taking place between an airplane and a ground station over level country, approximate ranges are:

1000 feet.....	30 miles
5000 feet.....	80 miles
10,000 feet.....	120 miles
20,000 feet.....	180 miles

### Radio Control Box

The radio control box provides the only complete remote control of communication functions. Five red buttons are the means by which any one of the 4 channels is selected and the power turned off. Pressing the "OFF" button turns off the dynamotor. The buttons are interconnected so that not more than one channel can be selected at a time. A light opposite each button indicates which channel you are using.

The "T-R-REM" switch (transmit-receive-remote) is normally in the "REM" position, permitting press-to-talk operation with the microphone switch on the control wheel, which when depressed switches the equipment from receive

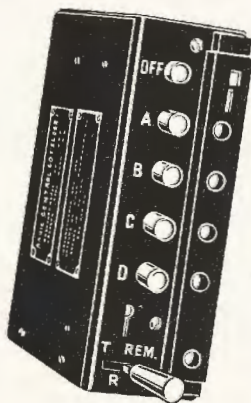

to transmit. In the "T" position the transmitter is in continuous operation. In the "R" position the receiver is in continuous operation.

The lever tab directly above the "T-R-REM" switch, when lowered, blocks the switch from "REM" position and spring-loads the switch lever so that unless it is held in the "T" position it will return to "R."

The small lever tab opposite the "OFF" button is a dimmer mask to reduce the lamp glare. The lamp opposite the "T-R-REM" switch is on when receiving and off when transmitting.

#### Transmitter-Receiver Assembly

The transmitter and receiver units are in a single case. The transmitter employs a crystal-controlled oscillator circuit and operates in the frequency range of 100-156 Mc on any of the 4 pre-set channels, A, B, C, or D. Average output power of the transmitter is 8 to 9 watts, using a total power input of 11.5 amps at 28 volts.

The receiver is a sensitive superheterodyne unit employing a heterodyne oscillator whose frequency is controlled by any one of 4 quartz crystals. Thus the 4 crystal-controlled channel frequencies are available for instantaneous selection at the remote control position. For reception the total input current is 11.1 amps at 28 volts.

#### Dynamotor Unit

The dynamotor operates on the 28-volt power circuit and supplies 3 regulated voltage sources

(300-volt DC, 150-volt DC, and 13-volt DC) required for operation of the VHF assembly.

#### Operation

The "T" and "R" positions of the control box permit transmission and reception without the use of the press-to-talk button. However, some aircraft are modified to eliminate the "T" and "R" positions, or have the control safetied in the "REM" position. It is advisable to use the "REM" position at all times.

To operate: See that the switch is in the "REM" position (if not safetied there).

Select a channel by pressing button A, B, C, or D.

To receive: Under these conditions the receiver is normally in continuous operation.

To transmit, depress the press-to-talk button and talk into the microphone.

To receive again, release the press-to-talk button.

To shut off the equipment, press the "OFF" button.

#### Precautions During Operation

Avoid prolonged use of the radio on the ground to conserve the batteries and avoid overheating the dynamotor.

If the transmitter and receiver fail to operate when a channel button is pressed, press another channel button, then again press the button for the desired channel. Transmission and reception should then be possible.

## LOCATION OF RADIO EQUIPMENT

Liaison transmitter . . . . .	On flight deck under the radio operator's table
Liaison receiver . . . . .	On flight deck on top of radio operator's table
Liaison dynamotor . . . . .	Under flight deck on right side (sometimes on floor of flight deck)
Liaison junction box . . . . .	On flight deck behind transmitter
Liaison monitor normal switch . . . . .	To right of liaison receiver
Interphone amplifier . . . . .	Behind copilot's seat
Interphone junction boxes . . . . .	13 positions throughout the ship
Interphone dynamotor . . . . .	On right side of liaison transmitter
Command transmitters . . . . .	Right forward side of half deck
Command receiver remote control head . . . . .	Roof of flight deck between pilot and copilot
Command receivers . . . . .	Center forward section of half deck
Command modulator power unit . . . . .	Right side of half deck
Command antenna relay . . . . .	Above the command transmitters
VHF transmitter-receiver and dynamotor . . . . .	Right side of half deck
VHF remote control unit . . . . .	Right side of control pedestal
Compass receiver . . . . .	Right side of half deck, facing center of ship
Compass control head (navigator's) . . . . .	In nose of ship above the navigator's table
Compass control head (pilot's) . . . . .	On flight deck above the pilot's head
Compass panel . . . . .	On aft side of compass receiver
Compass loop antenna . . . . .	Top side of fuselage near bulkhead No. 6
Compass whip (sense) antenna . . . . .	Top side of fuselage forward of loop antenna
Marker beacon receiver . . . . .	In bomb bay on left side of bulkhead No. 5
Marker beacon antenna . . . . .	Under cotwalk on bottom center of ship

## INTERPHONE EQUIPMENT

The interphone amplifier consists of a single dual-purpose tube amplifier powerful enough to allow adequate communication between all members of the airplane crew.

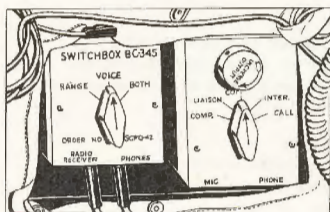

**FILTER SWITCH BOX AND INTERPHONE CONTROL**

The individual 13 interphone station boxes are located in these positions in late B-24's:

1. Tail gun position.
2. Camera hole position.
3. Side gun position (right side).
4. Side gun position (left side).
5. Bottom turret gun position.
6. Bomb bay.
7. Top gun position.
8. Radio operator's position.
9. Pilot's position.
10. Copilot's position.
11. Navigator's position.
12. Bombardier's position.
13. Nose gunner's position.

Steps for operating the interphone system:

1. The interphone system turns on when the main line and battery switches are turned on.
2. Plug your earphones in the phone jack at bottom of station box or in its extension cord.
3. Turn the selector switch A to "COMP" and you hear the compass receiver if it is on.
4. Turn the selector switch A to the "LIAISON" position and you hear the radio operator's liaison receiver if it is on. Press the microphone and you transmit over the liaison trans-

mitter. (Only the pilot, copilot, radio operator's and navigator's interphone boxes will operate the liaison transmitter.)

5. Turn the selector switch A to the "COMMAND" position and you hear the command receiver. Press the microphone button and you transmit over the command transmitter (from any position).

6. Turn the selector switch A to "INTER" and press the microphone button and you talk to any person in the ship who has his box on "INTER" position.

7. Turn the selector switch A to "CALL" position and manually hold it there while you call any interphone position in the ship. The person talking on "CALL" position will be heard throughout the ship no matter what position the other interphone boxes are turned to.

### Filter System

Pilot and copilot are provided with the FL-8A filter and switch box assembly. The filter is used for separating the voice (weather reports, etc.) from the beacon signal. Switching selector B to "RANGE" permits the reception of the beacon signal only. "VOICE" position permits reception of spoken messages only and "BOTH" permits beacon signal and spoken messages to be heard simultaneously.

### Trouble Shooting Steps for the B-24 Radio Equipment:

1. Check all the switches to see that the equipment is properly turned on.
2. Check all fuses in defective circuit.
3. Note whether there is input to the equipment by checking to see that the tubes in the equipment are lighted.
4. Tap radio tubes (in a defective circuit) and push them firmly in their sockets.
5. Remove the cover cap over each cable plug which connects into the defective circuit and check soldering connection on each wire.
6. Check the bonding from the defective equipment to the body of the ship.

## LOCATION OF RADIO FUSES

**LIAISON TRANSMITTER FUSE**—Pull out sliding coil in liaison transmitter. Fuse is in center section above where sliding coil unit goes in. Value is .5A 1000V. (Two spares are located on rack at base of coil unit.)

**LIAISON RECEIVER FUSE**—Unscrew two posts on the middle sides of receiver and pull the receiver from its case. Fuse is in bottom center of receiver. Value is 15A.

**LIAISON DYNAMOTOR FUSE**—Release 4 locks on dynamotor top casing and pull casing upward from dynamotor. Fuses are 1A 1000V, 60A-250V, and 30A-250V. (Dynamotor spare fuses are located in top of the dynamotor lid.)

**COMMAND TRANSMITTER AND COMMAND DYNAMOTOR FUSES**—Located above the bomb bay, between bulkheads Nos. 5 and 6, in the modulator power unit on the starboard side. Values are 20A each. (Two spares are located in the fuse cup on the port side of the modulator power unit.)

**COMMAND RECEIVER FUSES**—Located in fuse cup behind each receiver. Value is 10A. (One spare is located next to it.)

**COMPASS RECEIVER FUSES**—Located in compass panel which is on aft side of compass receiver. Values are 2A and 15A. (One spare is located next to each.) AC inverter power has to be on before compass receiver will work. AC power radio fuse will be found on flight deck in copilot's fuse box.

**VHF FUSES**—Located on right wall of half deck, behind transmitter-receiver unit.

**MARKER BEACON RECEIVER FUSE**—Run on power from compass receiver; uses compass fuses.



## RADIO COMPASS SCR-269

This radio equipment enables a pilot to obtain the following three conditions:

1. Aural reception of non-directional radio signals using a whip antenna. This condition is obtained on the "ANT" position of the pilot's remote control head.
2. Aural reception of radio signals using a shielded loop antenna. The loop antenna picks up considerably less snow and rain static but the volume is slightly less than that on "ANT" position. This condition is obtained on "LOOP" position of the pilot's remote control head.
3. Aural reception of radio signals using both the whip and loop antenna with a pointer to indicate the bearing of the station from the airplane. This condition is obtained on the

"COMP" position of the pilot's remote control head.

When the radio compass is used as a homing device, the indications are such that the aircraft will ultimately arrive over the radio station antenna regardless of the probable drift due to crosswind. However, the flight path will be a curved line, and coordination with ground fixes or landing fields along the route will be either difficult or impossible. Consequently, it is often expedient to fly a straight-line course by offsetting the aircraft's heading to compensate for wind drift. To do this, determine the wind drift, either with a drift sight or by noting the change in magnetic compass reading over a period of time, and making allowances for drift.

The radio compass operates on AC power and will not work if there is inverter failure.

### How to Operate the Radio Compass

To assume control at either pilot's or navigator's station, turn selector switch on radio

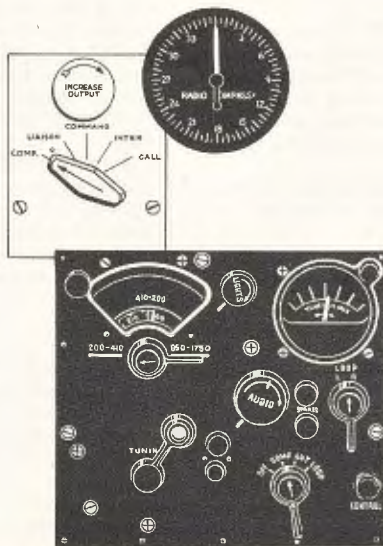

**Radio Compass  
Controls**

## RESTRICTED

compass control box to type of operation desired and press "CONTROL" button until green indicator lamp on control box lights. (Adjust dial lamps with "LIGHTS" control and headset volume with "AUDIO" control.)

Select station frequency with band selector switch and tuning crank. Move tuning crank to position producing greatest clockwise indication of tuning meter.

**Note:** Provision is made for reception of CW signals. Control of this feature is provided by the "CW-VOICE" switch on the panel of the radio compass receiver, located over the rear bomb bay.

1. To operate as a receiver only, using the vertical sense antenna:

- a. Set selector switch on "ANT."
- b. Push "CONTROL" button if indicator lamp does not indicate position control.
- c. Set band selector switch to desired band and tune in desired stations by means of tuning crank, making final adjustment by referring to tuning meter.
- d. Regulate headset volume by adjusting "AUDIO" control.

**Note:** If reception on "ANT" is noisy, operate on shielded loop antenna. Precipitation static existing in air-mass fronts at different temperatures can sometimes be avoided by crossing the front at right angles, and then proceeding on the desired course, instead of flying along the air-mass front.

e. To turn off radio compass, turn selector switch on radio compass control box to "OFF."

2. To operate as a receiver only, utilizing the shielding provision of the loop antenna to reduce precipitation static noises:

- a. Set selector switch on "LOOP."
- b. Push "CONTROL" button if indicator lamp does not indicate position control.
- c. Tune in desired station.
- d. Depress "LOOP L-R" knob, on radio compass control box and turn it to "L" or "R," rotating loop to obtain maximum signal strength, as indicated by headset volume. Release "LOOP L-R" knob and make final adjustment of loop position at slow speed by turning the knob to "L" or "R." Changing

course will affect signal strength, and necessitate readjustment of loop position.

e. Regulate headset volume with "AUDIO" knob.

**Note:** If loop is in null (minimum signal) position when flying on a radio range course, the signal may fade in and out, and possibly be mistaken for a cone of silence. When operating on "LOOP," cone-of-silence indications from radio range stations employing loop-type radiators (shown on radio facility chart) are not reliable. The signal may increase in volume to a strong surge when directly over the station, instead of indicating a silent zone.

f. To turn off radio compass, turn selector switch on radio compass control box "OFF."

3. To operate as an aural null homing device, utilizing the directional characteristics of the loop antenna:

- a. Set selector switch on "LOOP."
- b. Push "CONTROL" button if indicator lamp does not indicate position control.
- c. Tune in desired (preferably clear channel) station.
- d. If loop indicator pointer is not at zero, depress "LOOP L-R" knob and turn it to the "L" or the "R" position until the pointer rests on zero. Final adjustment of loop position can be made at slow speed by releasing "LOOP L-R" knob and turning it to "L" or "R."

e. Turn "AUDIO" control fully clockwise and head airplane in proper direction, based upon the null indicated in the headset. (The broadness of the null depends on the strength of the signal. Strong signals produce very sharp nulls, sometimes as small as one-tenth of a degree.) Vary "AUDIO" control until the null is of satisfactory width. The tuning meter may be used as a visual null indicator.

**Note:** When determining direction of flight by this method, remember that the airplane may be flying either directly toward or directly away from the station. If direction of flight with regard to this ambiguity is not known and radio compass won't work on "COMP," a standard orientation procedure must be executed before flying any great distance along the null.

- f. To turn off radio compass, turn the selector switch on radio compass control box to "OFF" position.
4. To operate as a homing compass, utilizing the unidirectional characteristics of the radio compass when operating with the vertical and loop antenna:
  - a. Set selector switch on "COMP."
  - b. Push "CONTROL" button if the control indicator lamp does not indicate position control.
  - c. Tune in desired station.
  - d. Apply rudder in direction shown by radio compass indicator until pointer centers on zero. This indication is unidirectional; as long as pointer rests on zero, the airplane is headed toward the transmitting antenna of the radio station.

## Note

The airplane's flight path toward the antenna may be a curved line unless its direction is offset to compensate for wind drift, as determined by the drift sight or by noting the change in magnetic compass reading while homing on the radio compass.

e. Regulate headset volume by adjusting "AUDIO" control.

f. Since a pronounced AVC action may be present when operating the radio compass on "COMP," aural indications received on this position should not be used when homing on a radio range station.

g. To turn off radio compass, turn selector switch on control box to "OFF."

## IMPORTANT

There are many uses of the radio compass which are invaluable to the airplane commander. An excellent description of its uses will be found in T. O. 30-100B-1, Instrument Flying Advanced With Radio Aids.

## MARKER BEACON RECEIVER

The marker beacon receiver picks up 75 Mc signals used in radio navigation and landings and reproduces them visually through a light on the instrument panel. When the airplane is over a keyed transmitter, such as a CAA marker, or certain types of Army transmitters, the indicator lamp on the panel flashes the identifying signal of the transmitter. The receiver unit is installed in the bomb bay.

The receiver operates automatically on power drawn from the radio compass; hence, for marker beacon reception, your radio compass must be on and operating.

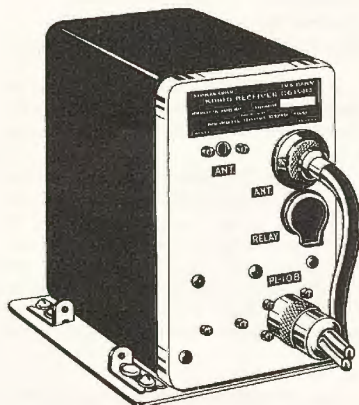

---

## WHAT YOU LOSE WHEN YOU LOSE AN ENGINE

**No. 1 Dead**—You lose generator and vacuum pump which affects all gyro instruments and de-icer boots. Switch vacuum to No. 2 to restore suction for gyros and for de-icer boot operation.

**No. 3 Dead**—You lose generator, heaters for bombardier, navigator and radio operator and you lose the engine-driven hydraulic pump. This affects flaps, gear, brake accumulators and bomb doors.

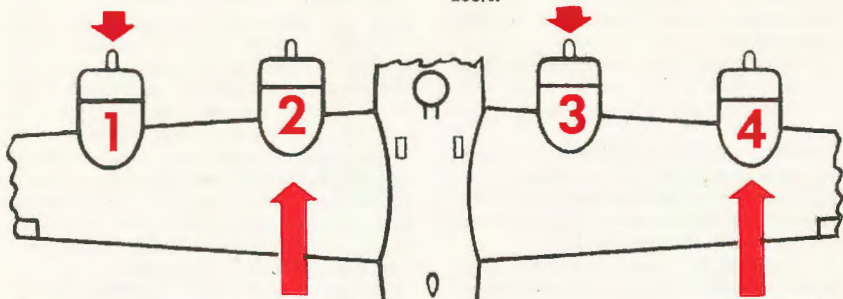

**No. 2 Dead**—You lose generator, heaters (for pilot, copilot and top turret gunner) and vacuum pump. Switch vacuum to No. 1.

**No. 4 Dead**—You lose generator affecting electrical system.

**NOTE: GYROS SPILL WITHIN 3 TO 5 MINUTES WITHOUT SUCTION.**

---

## ENGINE FAILURE ON TAKEOFF

The value of an engine-failure procedure is the fact that it prepares a pilot in advance for emergencies. It gives you a plan of action that will help you to do the right thing at the right time, smoothly and efficiently.

### Procedure

1. If there is room enough, the best thing is to throttle back and stop the take off.
2. If it is too late to stop (as is usually the case), use all available runway to build up flying speed.
3. As long as yaw is less than that of a wind-milling propeller, without excessive vibration

or dangerous instrument indications, don't be in a hurry to feather. (See Feathering.) Feather only when you **know** you have located the failing engine.



4. Get and keep control with rudder and minimum aileron. Insufficient rudder and too much aileron will put you in a forward slip and you

## RESTRICTED

will be unable to gain airspeed or altitude. Use as much power as you need to clear obstructions, but no more than you can fully control. When you have good control and a safe altitude, trim rudder to relieve yaw, level the wings and center the ball to get maximum flying efficiency. Provided airplane was properly trimmed beforehand, you will not need aileron trim.

5. Hold the nose at the minimum angle of climb necessary to clear obstructions. You want to gain airspeed as fast as possible.

6. Start the gear up as soon as you are safely clear of the ground. Hold your minimum angle of climb until the gear is up and gear handle has kicked out.

7. When you have airspeed of 135 to 140 mph raise the flaps in two to three stages to 5° to 9°. (Airplane has most lift and stability with this flap setting.) Raise the nose enough to maintain climb and still build up airspeed.

8. Above all, don't attempt any turns while climbing. Climb to a safe altitude and airspeed and get up on the step before starting a turn.

9. Request emergency landing clearance from the tower, preferably with a pattern that will permit you to make turns with the live engines on the inside of the turn. Avoid any violent maneuvers. Make shallow turns and remember that you'll have a longer radius of turn because of unbalanced power.

### Failure of Engine No. 1

If No. 1 fails and you are using maximum take-off power, it will require all available rudder to hold the airplane straight because of yaw plus torque. If vacuum selector is on No. 1, switch to No. 2 so gyro instruments won't spill.

### Failure of No. 2 Engine

Less rudder will be necessary to hold airplane straight and to level wings if No. 2 or No. 3 fails. Switch vacuum (if on No. 2) to No. 1.

### Failure of Engine No. 3

You should be able to raise the wheels without using the auxiliary hydraulic pump if the engine is delivering any power at all or even if it is windmilling.

If you have feathered the propeller, the en-

gine-driven hydraulic pump will not operate. Then, have engineer turn on the auxiliary hydraulic pump switch and open the star valve to get the gear and flaps up. Then turn the start valve off until needed to get the gear and flaps down.

### Second Engine Failure on Takeoff (This shouldn't happen to a dog)

Even if 2 engines should fail on the same side it is usually possible to fly the airplane with a normal load. The object is the same as in single-engine failure: to keep the ball centered to get maximum lift. This will take every inch of available rudder that pilot and copilot can hold.

One method is to pull war emergency power with the live inboard and retard the outboard to maximum climbing power. Use all the horsepower you can get and control, but it is no good to you unless you can hold the airplane in a maximum-lift attitude, wings level.

Jettison as much load as possible. Proceed as in a single-engine failure. As soon as you have gear and flaps up, and a safe airspeed, you can probably maintain a shallow climb with less power. Do your climbing straight ahead.

If 2 engines fail on opposite sides, you will have no serious problem maintaining direction and can use more balanced power settings.

**Caution:** Under no condition try to turn back to the field. If the airplane is sinking too much, execute a landing straight ahead. Warn the crew in advance and carry out the procedure for crash-landing on land as far as time permits.

**Remember:** Don't slack off on rudder and use ailerons. You are better off with a little less power and an efficient flying attitude. Wait until after you have gained control to trim. Don't attempt to get control with trim.

Don't try to turn back to the field.

Use all your strength on rudder and then use as much power as you can hold. Center the ball if you want the airplane to fly.

After flaps are at 5° to 9°, never let the airspeed get below 145 mph even if you have to sacrifice altitude.

Smooth application of controls is vital. Use gradual, steady pressures. Nurse 'er, brother, nurse 'er and she'll fly!

## ENGINE FAILURE IN LEVEL FLIGHT

The same principles apply here as in other situations when an engine is losing power. However, you have more time in which to regain control of the airplane, your wheels and flaps are up, and it is seldom necessary to use excessive power for any extended period.

There is nothing critical about an engine failure in the B-24. If you know how to get the airplane under control, how to use power and when and when not to feather, you can bring 'em back alive from a long way out. Combat pilots are doing it all the time. Sincere concentration and a desire to learn in ground school, on the flight line, and in the air, and thoughtful study of the airplane and technical orders, will rapidly prepare you to meet any situation. Know everything this manual has to tell you and you'll feel secure in most situations.

### POWER SETTINGS FOR 3-ENGINE CRUISING



Normally, with one engine dead, maximum cruise power settings will easily maintain level flight. When the engine first fails, you may want to use maximum climbing power and, in combat, danger from the enemy or maintaining position in formation will govern your actions. But don't pour the power on unreasonably. Second and third engine failures too often are induced by using power improperly. Handle

your power with kid gloves to avoid failures.

Refer to the 3-Engine Cruise Control Chart for power settings, airspeed and fuel consumption.

#### Inboard or Outboard Failure

For cruising purposes, it makes little difference whether an inboard or an outboard engine fails. An outboard will require a little more rudder pressure to regain control, especially if No. 1 fails. Remember, if No. 1 or No. 2 fails, to switch vacuums at once. You need your gyro instruments to fly a B-24, especially with an unbalanced power condition or if you are on instruments.

#### Failure of No. 1 or No. 2 When De-icers Are Working

When cruising in icing conditions with de-icers working, failure of No. 1 or No. 2 cuts off half of the pressure to de-icers. When you switch vacuum to the live engine, there is full pressure for inflating de-icers but there is no vacuum for deflation and you have to depend on external air pressure for deflating boots. You can divert all the suction to deflating by switching vacuum to the dead engine for 30 seconds periodically and then back to the live engine to maintain proper suction for gyro instruments. You'll only need to do this under severe icing conditions. It takes 45 seconds for the complete cycle of inflation and deflation of de-icer boots.

#### Failure of 2 Engines in Flight

If 2 engines fail, it is possible to fly the airplane in all gentle maneuvers within engine power limits. Normally, "AUTO-RICH," 2300 rpm and 34" manifold pressure will suffice. Don't forget the sequence for increasing power.

Based on 50,000-lb. weight, 5000 feet density altitude and 1200 gallons of fuel available, this power setting will maintain level flight at 152

## RESTRICTED

mph indicated (164 true airspeed), and will give a maximum range of 970 miles with no wind. Under the same conditions except cruising at 10,000 feet your airspeed would be 143 mph indicated, 167 mph true airspeed, and range would increase to 1030 miles. You could not maintain altitude at 15,000 feet with 2 engines dead, and would want to descend to 10,000 feet.

If 2 engines are out on one side, you may have to increase power with a resultant sacrifice in range. In this case, your immediate problem will be to regain directional control and keep the dead-engine wing from dropping below level flight. This will call for all possible rudder pressure and maximum smoothness in flying. Get control, center the ball, hold and trim. If you can't trim out all the yaw, slightly increase rpm and power on the live inboard and decrease power and rpm on the live outboard to assist in trimming. You will still have to hold some rudder. Remember that you probably can't maintain altitude with both landing gear and flaps down. (See 2-Engine Landing.)

**Caution:** If you continue to lose altitude with 2 engines dead there are several choices. First try 5° to 9° of flaps. This will usually reduce descent 200 to 300 feet a minute. Then jettison all possible cargo. You should be able to maintain altitude with 5° to 9° of flaps and 145 mph. If still losing altitude at 2000 feet above the terrain, bail out the crew.

### Concealed Engine Failure

During cruising flight it is not always apparent that an engine is failing. Yaw may be slight if the guilty engine is an inboard and if the turbo-supercharger is not operating. A windmilling propeller can maintain engine readings on the tachometer, oil pressure, and manifold pressure dials within operating limits, concealing the failure.

Assume throttles are open, turbo-superchargers are operating and an engine fails. Manifold pressure for that engine will immediately drop to approximately atmospheric pressure for the altitude which you are flying. However, if turbo-superchargers are not engaged, manifold pressure would show no substantial drop when an engine fails.

Fuel pressure will remain normal in a regularly functioning fuel system. Low temperature readings of cylinder-head temperature and oil temperature gages may be the only symptoms of such a failure. Cylinder-head temperatures are the first to react and should be closely observed. If you are inexplicably losing airspeed and or altitude, you may be experiencing such a failure.

On automatic pilot, controls will suddenly get busy and tend to cross, and airspeed will fall off, in addition to engine indications.

### Turns With Dead Engines

**Warning:** Never attempt turns unnecessarily while climbing with one or more engines dead.

1. Be sure the airplane is under control and trimmed, and, if necessary, power balanced. Then, with one engine dead, or an engine dead on each side, even though one is an outboard and the other an inboard, you won't have trouble controlling the airplane in the turn if you keep banks shallow and maintain airspeed.

2. Plan ahead so you have a world of room in which to make the turn and so you will turn into the live engines.

3. Use shallow banks, not to exceed standard rate one-needle-width turns.

4. Use smooth but strong application of rudder. The airplane will resist the turn because you are turning **against power** and will require a larger radius in which to complete the turn.

5. Use a minimum of aileron to effect the turn. Excessive use of ailerons creates excessive drag, and can produce an aileron stall without warning. A violent aileron stall can turn the airplane on its back.

### A Turn Into a Dead Engine

Normally it is not necessary to make a turn into a dead engine. About the only case would be if an engine failed on the side toward the field on the base leg. If that should happen, it would probably be better to turn into the dead engine to line up on final approach than to turn through 270° in the opposite direction. You can make a shallow turn into a dead engine safely, provided the airplane is flown in a coordinated manner (center the ball). Remember not to allow the nose to get up, and maintain 145 mph with 5° to 9° of flaps.

## ENGINE FAILURE IN TRAFFIC

It is one thing to approach traffic with altitude to spare, dead engine feathered, gear up and time to plan. It is a somewhat different problem to be flying in traffic and have an engine fail. Assume that you have just started on the downwind leg, wheels down, and have started the checklist and an engine fails—then what?

Your first step is to get complete control of the airplane, increasing power if needed, mixtures to "AUTO-RICH," props to 2550, power to give full control. If there is violent vibration, feather as soon as you can be sure which engine is at fault. At the earliest possible moment notify the tower to clear traffic—you don't want

to have to go around if it can be avoided. Immediately order gear up to reduce drag. If No. 3 has failed, have the engineer switch on the auxiliary hydraulic pump and open the star valve to bring the gear up. Gear will come up in 30 to 40 seconds. After gear is up and flaps are at 5° to 9°, turn off the switch but leave the star valve open ready to bring the gear and flaps down when you again start pump on final approach. Now complete the checklist. From there on, use the same procedure as in other dead-engine landings, keeping your base leg close in and lowering gear on final approach when you know you can make the field, lowering flaps when the gear handle has kicked out, etc. (Gear will come down and lock in approximately 25 seconds.)

If the failure occurs close enough to the field so that your position and altitude permit a normal landing, don't raise the gear. Use enough power to bring you safely into final approach.

## LANDING WITH ONE OR MORE ENGINES DEAD

Pilots with average ability can safely land the B-24 with one or 2 engines dead if they plan ahead properly and follow correct procedures.

### Approaching Traffic

It is most important that you notify the tower well in advance that you have a dead engine and want to make an emergency landing. Request a traffic pattern which will keep the dead engine high on all turns. The tower should get other ships out of the pattern and give you the right of way.

### Procedure for 3-Engine Landing

1. Approach traffic and fly the traffic pattern 500 feet higher than normal at an airspeed of 150 mph.
2. Otherwise place and fly the downwind leg in the normal manner, except **keep the gear up** until final approach. On the downwind leg com-

plete other items of the checklist as usual, including 5° to 9° of flaps to stabilize and improve the lift characteristics of the airplane.

3. Shorten the distance you fly out on the last part of the downwind leg in order to keep your base leg in closer so that there will be less danger of undershooting on final approach.

4. Start your turn substantially earlier, because against power the radius of turn will be greater. **Don't** get the nose up and **do** maintain airspeed in the turn at 150 mph if you have to lose a little altitude to do so.

5. Again start your turn earlier than usual from base leg into final approach. If necessary, retard the throttle slightly on the outboard nearest the field to help turn. Start the final-approach checklist in the turn. Procedure is the same as usual except for gear and flaps.

6. Roll out of the turn with rudder and line up for final approach. Judge your distance carefully and be sure you can make the field before ordering the gear down. Maintain 140 mph until gear is down and locked. Engineer won't be



## RESTRICTED

able to check the main gear locked because you have 5° to 9° of flaps, but he can and must check the nose gear.

7. As soon as the gear handle kicks out (and not before) and when you are sure you can make the field, call for full flaps. This noticeably increases lift and tends to lengthen your glide, so as flaps come down, reduce airspeed to 125 mph by reducing power. It is a good idea to use 5 to 10 mph higher airspeed than this on final approach if the length of runway permits.

8. As airspeed drops and you reduce power, re-trim to normal tab settings because you no longer have an unbalanced power condition.

9. From then on it is a normal landing. Keep on enough power to control your rate of descent. Power reduction on final approach will vary depending upon which engine is out. With a dead outboard, you would throttle back the active outboard (as flaps come down) to about 12" manifold pressure to give a normal tab setting.

Keep sink to a minimum with the inboard engines. Once you have a high rate of sink, it is hard to stop because of inertia. With a dead inboard, reduce the active inboard first and land with the outboards. As you make contact, close the 3 throttles together. **Note:** If No. 3 engine is dead, have the engineer switch on the auxiliary hydraulic pump and open the star

valve when you want to bring flaps and gear down. After they are down on final approach have the star valve closed, but leave the switch on so the auxiliary hydraulic pump will charge accumulators.

### Landing With 2 Engines Dead

In general the procedure is identical with that of a 3-engine landing with these exceptions:

1. Approach and fly traffic 1000 feet higher than normal.

2. Maintain a slight descent throughout the pattern to maintain airspeed, and fly turns with the greatest care to lose minimum amount of altitude. Don't let the airspeed drop below 145 mph with 5° to 9° of flaps.

3. You should enter the turn on final approach about 500 feet higher than normal.

**One engine dead on each side:** Power can be easily balanced even though one is an outboard and the other an inboard.

**Two engines dead on the same side:** This is your most unbalanced power condition. Except more difficult turns in which it may be necessary to reduce power on the active outboard. On final approach gradually reduce power first on the active outboard and re-trim; control rate of descent with the inboard engine.

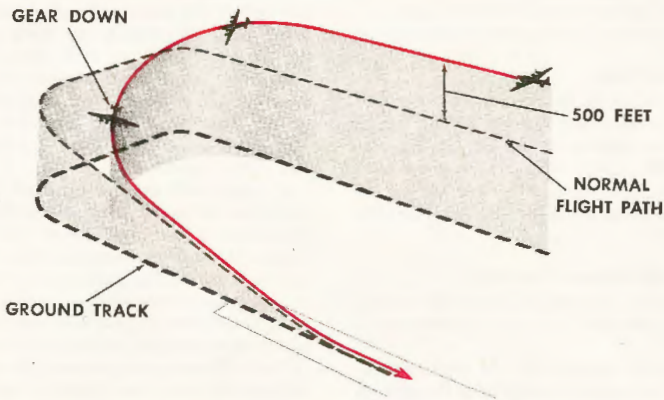

### 3-ENGINE GO-AROUND

This won't happen to you if you have been living a good clean life. You are on final approach with a dead engine, gear down, full flaps down and gliding at 125 mph when the tower orders you to go around. The sequence of operations is most important.

#### Procedure

1. Lead with balanced power. If an inboard is dead, lead with the outboard throttles. If an outboard is dead, lead with the inboards and follow gradually with the unbalancing throttle to avoid getting power on that you can't hold with rudders until your speed increases.

2. As always with a dead engine, the important things are a shallow climb and level wings to gain airspeed as rapidly as possible.

3. Get at least 125 mph before you call for flaps to 20°. As the flaps come up, slightly increase the angle of attack enough to avoid sink.

Airspeed should immediately build up to 135 to 140 mph.

4. Important: Here's where sequence is important. Raise the flaps ahead of the gear, because it takes 30 seconds for the gear to come up and during that time you would have the drag of full flaps. When you have brought the flap handle to neutral, order the gear up.

5. With this procedure, you should have no trouble controlling enough power to gain adequate airspeed for climbing. As soon as you have 135 to 140 mph and a safe altitude raise flaps to 5° to 9° and keep this setting for maximum flying efficiency.

### Note

If you are about to overshoot on final approach, don't dissipate altitude with a nose-high attitude. Reduce power and dive. This requires good technique, and you must start your flare-out slightly higher than normal.

## AC POWER OR INVERTER FAILURE

If you feel that instruments are indicating with an uncanny steadiness, **don't reach for a feathering button.** There is probably inverter or AC power failure. Inverters change direct current from the batteries to alternating current to operate autosyn instruments and other units. There may be a fuse blown, inverter trouble, or an inverter fuse blown. You know there is nothing radically wrong with the airplane because there is no yaw, no vibration, and you are maintaining your airspeed, so don't feather. It is very unlikely that all 4 engines will fail at once. Cylinder-head and oil temperatures are still indicating normally.

**Test for Inverter Failure:** Turn the booster pumps on or off and observe the action of the fuel pressure gage. A variation in pressure indicates that the inverters are functioning. An alternative check is to watch the operation of the remote-indicating compass or the radio compass.

#### Effect of AC Power or Inverter Failure

1. Autosyn instruments (electrically operated) will tend to stay put or creep slowly down. On many airplanes this includes the tachometers, manifold pressure gages, fuel pressure gages and oil pressure gages. However, instruments controlled by AC power may vary on later models.

2. Other instruments will continue to register normally.

3. Radio compass will fail to function since it is on AC power:

4. At night:

a. Magnetic compass lights will go out.

b. Tube-type fluorescents will go out.

5. A-5 automatic pilot will cease to function.

6. Electronic supercharger, if so equipped, will lock waste gates in the position they are in when inverter fails. This gives no cause for immediate alarm but must be considered in changes of altitude and power settings.

## RESTRICTED

### Remedy:

Switch to the other inverter; if this fails, check all fuses concerned. These measures will usually restore your AC power. That's why you have extra fuses and 2 inverters but normally use only one—so that you'll have a spare inverter if needed.

**Warning:** If you have had inverter failure with an electronic supercharger control, keep your hand on the throttles when you switch inverters and control any manifold pressure fluctuations for at least 2 minutes to allow the amplifier to warm up. If circumstances permit, reduce power during this period.

### Automatic Change-over

On some late series aircraft an automatic change-over relay switches to the spare inverter if the main one fails. A red light on the instrument panel flashes on to warn you that the main inverter is dead. The relay will not switch from spare to main, so always operate on the main inverter.

### Flight Procedures in Case of Complete Failure

The most important thing is to keep your head:

1. Don't feather. Don't change power. Keep the airplane flying straight and level!
2. Fly the airplane by means of the altimeter, flight indicator, rate-of-climb indicator and your airspeed indicator.
3. You know the power setting you were using. Mark the throttle quadrant so you won't be tempted to shove on excessive power. Remember your airspeed indicator (in level flight) is a direct guide to the power you are getting.
4. If necessary to descend from high altitude, reduce power, and establish a nominal rate of descent. When you level off, judge increase in power by airspeed and re-establish power to give you the same indicated airspeed as higher up.
5. In case of a descent when equipped with electronic supercharger, your power reduction will have to be made entirely with throttles.
6. It is a good idea to land at the nearest suitable airfield.

### Landing

You can make a normal landing without difficulty if AC power fails. Judge power settings by eye, ear, and flight instruments.

## RUNAWAY PROPELLERS

The most important fact to keep in mind about a runaway propeller is **not to feather it** until you have tried out the 2 procedures which should give you control of it. Drill these procedures into your copilot so he will understand his part in controlling a runaway propeller.

It is seldom that a propeller runs away in a B-24. When it does happen, it is usually on take-off, and it is imperative to know what is happening and how to regain control. A first step in knowing what to do is understanding normal operation of the propeller. You have two controls over its performance: "INCREASE"- "DECREASE" toggle switches on the pedestal, and fast-feathering buttons above the compass at the top of the windshield. Prop governor lights operate when the governors reach their limit of travel in either direction. For normal operation, you select the most desirable rpm by holding the toggle switch toward "INCREASE" or "DECREASE." A governor unit maintains the selected engine speed during all subsequent flight conditions, limited only by the angle of blade rotation possible, which is determined by pre-set governor limits. Automatic control of engine speed is obtained through the propeller by varying the blade angle to maintain a constant load on the engine: e.g., reducing the blade angle when the load increases, as in a climb.

### What Causes a Propeller to Run Away

When a propeller runs away, it simply means that the propeller governors fail to hold the propeller at its constant rpm setting. Thus, before takeoff when engines are idling, propeller is in low pitch (small bite), high rpm. Sudden

and fast application of power may cause a propeller to exceed the governor limit speed before the governor has a chance to take hold and increase the pitch. Governor cannot regain control until you throttle back and give it a chance. This is usually the case with a runaway propeller. However, if you have complete governor failure, you may not be able to regain control with throttle alone and will have to use the feathering button intermittently as described in the procedures that are given.

#### Preventive Action

The best way to cope with a runaway propeller is not to get one. Carefully observe tachometer reactions during run-up. Don't jam power on during takeoff. Apply it smoothly. If rpm starts to get out of bounds on an engine during first part of run, don't take off if you have room left in which to stop.

#### How to Regain Control

Always try this first, during takeoff and in flight. It may give you immediate control of the propeller so you can obtain a normal rpm setting.

##### First Procedure:

1. Reduce the throttle. This is the first thing necessary to slow the propeller down.
2. Work the toggle switch to decrease rpm. This should slow the propeller down.
3. If this works, reset your throttle, keeping close track of rpm. If it fails, then resort to the second procedure given here.

##### Second Procedure:

This procedure is recommended for heavily loaded airplanes because it gets more power from the engine.

1. Be sure throttle is reduced.
2. Copilot (at pilot's direction) pushes the feathering button in, holds onto it and watches rpm. **Be sure to get the right one** or you'll be short 2 engines. Take your time!
3. As the propeller decreases the rpm, increase the throttle to obtain climbing manifold pressure and rpm of 2500.
4. When you reach 2500 rpm, forcibly pull the feathering button out. This will keep rpm from going lower. If governor doesn't take control of rpm, it will immediately start back up.
5. When propeller reaches 2700 rpm, push feathering button in again and repeat the procedure to keep rpm between 2500 and 2700 and to maintain desired manifold pressure. Continue this until you have reached an altitude where you can safely feather the propeller.

## Caution

**Don't be in a hurry to feather. If either of these procedures is keeping the propeller below 2700 rpm, you are getting some power from the engine — possibly as much as 15% with the throttle reduced and up to 65 or 70% if the second procedure is working.**

# EMERGENCY FEATHERING

Feathering has a fatal fascination for some pilots. Say "Boo" and their fingers fly to the feathering buttons.

No emergency is urgent enough to justify feathering the wrong engine. Then you are short 2 engines. Remember, it is easier to throw power away than to get it back.

If there are indications of engine failure you are faced with 3 questions:

1. Which engine is failing?
2. What's wrong with it?
3. Does the failure call for feathering?

The answers to these questions are nearly always with you in the airplane. You can find them if you have learned how to read the signs: Yaw, vibration, increasing or decreasing temperatures and pressures, excessive rpm, manifold pressure, etc. Some of the questions and answers are given in this section.

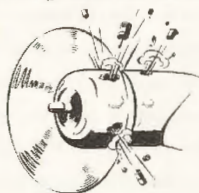

Feathering has several important advantages:

1. Minimizes damage to engine if failure is caused by an engine part.

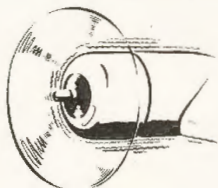

2. Eliminates vibration.

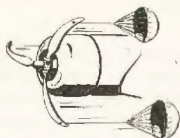

3. Improves flight performance of airplane (if engine is dead) by eliminating the drag of the windmilling propeller.

Feathering has equally important disadvantages:

1. Danger of feathering wrong propeller, caused by featheritis. Pilots have been known to feather 4 propellers. If you are that confused, you might better use your time for bailing out.

2. Unnecessary loss of power from feathering when a reduction of power and proper procedures might have solved the problem or given at least partial power.

**Knowing When to Feather Is Fully as Important as Knowing How to Feather.**

### Emergency Feathering Checklist

1. Throttle back
2. Feather
3. Mixture and fuel booster pump off
4. Apply power on live engines
5. Gear up
6. Trim ship
7. Cowl flaps closed
8. Ignition off
9. Generator off
10. Fuel valve off

In Case No. 1 or No. 2 Engine Fails or Both:

- Check vacuum
- Radio compass on (for direction aid by homing)
- Autopilot tell-tale lights

### Unfeathering

1. Fuel valve on
2. Ignition on
3. Prop low rpm
4. Throttle cracked
5. Supercharger off (oil regulated supercharger only)
6. Unfeather
7. Mixture "AUTO-RICH," booster pump off
8. Warm up engine
9. Generator on

## AMPLIFIED EMERGENCY FEATHERING CHECKLIST

1. **Throttle back.** This procedure helps eliminate the possibility of feathering the wrong propeller. If you throttle back the wrong engine, you will increase yaw on the dead engine side.



2. **Feather.** Upon determining which engine is defective, pilot presses feathering button in and removes hand. Button should kick out when propeller feathers. If not, propeller will unfeather. In this case, press button again and pull it out when the propeller stops in the feathered position.



3. **Mixture and Fuel Booster Pump.** Copilot moves mixture control to "IDLE CUT-OFF" and switches fuel booster pump off. This is necessary at times to stop the engine.



4. **Application of Power.** Copilot adjusts mixture controls on other engines and increases rpm. Pilot increases manifold pressure. Actions of pilot and copilot are approximately simultaneous, but the increase of mixtures and rpm should always precede the increase in manifold pressure.

RESTRICTED



5. **Gear Up.** If the landing gear is extended, copilot retracts it.

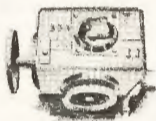

6. **Trim Ship.** Accomplished by pilot.



7. **Cowl Flaps Closed.** Copilot closes the cowl flaps on the dead engine to decrease the drag and opens the cowl flaps on the live engines to the trail position if cylinder-head temperatures are high.



8. **Ignition Off.** Copilot cuts ignition switch for dead engine.



9. **Generator Off.** Engineer switches off generator on dead engine.



10. **Fuel Valve Off.** Engineer turns off main fuel valve of dead engine.

## RESTRICTED



### In Case No. 1 or No. 2 Engine Fails, or Both:

**Vacuum:** Pilot checks vacuum if No. 1 or No. 2 engines are stopped. Engineer changes vacuum selector position if necessary.

**Radio Compass:** Copilot tunes in radio compass to nearest station so that if both No. 1 and No. 2 engines are stopped, pilot may fly instruments by using the radio compass as a turn indicator and to maintain direction by homing from one station to another. Level flight may be maintained by reference to the ball-bank indicator for lateral attitude, and by reference to airspeed, rate of climb and altimeter for longitudinal attitude.

**Automatic Pilot Tell-Tale Lights:** If both No. 1 and No. 2 engines are stopped, there will be no suction for operation of the gyro instruments. Since the autopilot is equipped with electric gyros, the pilot can turn it on, trim ship and refer to the tell-tale lights to maintain level-flight attitude. Using this procedure, the autopilot clutches should not be engaged. This can only be done with the C-1 automatic pilot.

## UNFEATHERING



1. **Fuel Valve On.** Engineer turns on main fuel valve.



2. **Ignition On.** Copilot turns on ignition switch.



3. **Prop Low rpm.** Copilot checks to see that propeller is in full low rpm position.



4. **Throttle Cracked.** Pilot cracks throttle.



5. **Supercharger Off.** Pilot checks to see that supercharger control is in off position (with oil regulated supercharger only).



6. **Unfeather.** Pilot holds feathering button in until 800 rpm is indicated and then releases it.



7. **Mixture Auto-rich.** Copilot puts mixture control in "AUTO-RICH," booster pump off.

8. **Warm Up Engine.** Warm up engine at 20" manifold pressure in "AUTO-LEAN." Increase power gradually as cylinder-head temperature rises.



9. **Generator On.** When power is increased as engine warms up generator is turned on.

#### After Feathering

Once an engine is feathered there is always danger of the failure of the remaining 3 engines. Reports of B-24 accidents prove this point. Reason: Subsequent failures are caused by pouring on the coal to the remaining engines without regard for proper power settings, bringing on detonation and a complete loss of power.

Be careful with that boost. Pilots who are perfectly aware of the danger of a heavy hand on the throttles make this mistake. If you have it to spare, sacrifice some altitude to get the airplane flying. Steady flying is imperative for 2 and 3-engine operation. If necessary, throw some things overboard. Don't burn up the engines with excessive power.

#### Feathering Trouble

1. **If You Feather the Wrong Prop:** You can stop the propeller from feathering if rpm is not below 1000 by pulling out the feathering button. But at less than 1000 rpm, feathering must be complete before unfeathering starts.

2. **If Propeller Feathering Buttons Do Not Work:** Hold the circuit breaker button down (not more than 90 seconds) while operating the feathering button. Circuit breaker buttons are red buttons on top of pedestal.

3. **If Propellers Feather and Unfeather Without Stopping:** Wait until propeller is in feathered position and pull out the feathering button.

4. **If You Have Lost All the Oil and Can't Feather:** Put propeller control in low rpm to reduce windmilling drag as much as possible.

Engine oil systems provide oil for operation of the propeller feathering system. On early airplanes, the feathering pump draws its oil supply from the "oil-in" line to the engine. On later planes, the feathering pump draws its oil supply from the sump at bottom of the oil tank.

## QUESTIONS AND ANSWERS ON FEATHERING

1. Q. What is the general rule regarding feathering?

A. An engine losing power should not be feathered as long as yaw is less than that of a windmilling propeller, if there is not excessive vibration and as long as instrument readings are within reasonable limits. Reason: because the power you are getting from the engine more than offsets the reduction in drag obtained from feathering. Remember that engine failure causes a loss of manifold pressure only if turbo-superchargers are engaged.

2. Q. Would you feather the prop of an engine that was violently vibrating?

A. Yes, if it continued to vibrate after reducing throttle, because violent vibration can cause the engine to go to pieces or cause wing structural failure.

3. Q. How can you tell you have a useless windmilling propeller and which engine is causing the trouble?

A. First by yaw. The airplane will yaw in the direction of the dead engine, so you know which side it is on. Then a close scrutiny of instrument readings will tell you by excessively high or low readings which engine is at fault, particularly by low cylinder-head temperature.

4. Q. Would you feather the prop of an engine that showed decreasing oil pressure?

A. Yes, if oil pressure falls below 30 lb. There may be a broken oil line and you want to get the propeller feathered before all the oil runs out. At least one gallon of oil is required in the feathering operation.

5. Q. If there is violent vibration, how can you tell which engine is at fault?

A. First by visually checking to see which engine is vibrating. Then by checking cylinder-head temperature, which would probably be excessively high, and by checking rpm for fluctuation.



# MECHANICAL FAILURES AND PROCEDURES

## EMERGENCY LOWERING OF LANDING GEAR

There are 4 ways to lower the gear on a B-24. It is seldom that all 4 fail. Recently a pilot flew around for 2 hours trying to figure out with an ignorant engineer how to get the gear down. Then, with 5 minutes of gas left, he executed a belly landing which did \$75,000 damage. Investigation showed that 60 seconds of know-how would have put the gear down.

**Know all emergency procedures.** Rehearse them with your engineer and copilot. Take an afternoon and crawl around the airplane with them. Read each procedure and dry-run it on the spot. That's the way to get acquainted with your airplane. Then, if an emergency arises, you'll be ready.

### METHODS OF LOWERING THE LANDING GEAR

1. Normal hydraulic operation.
2. By use of the auxiliary hydraulic pump.
3. By use of the hand hydraulic pump, front star valve open, rear star valve closed.
4. Emergency hand crank method.

**Important:** First try all hydraulic methods of lowering the landing gear.

### Know Your Landing Gear

Know whether the emergency landing gear lowering system in your airplane is **early design**, with cable connection between emergency hand crank and nose gear, or **later type**, without cable connection. Most airplanes of early design have been modified; check yours, and if it hasn't been modified, refer to Tech Orders for proper procedure. Successful emergency lowering of landing gear depends on this procedure.

**Procedures applicable to later B-24 aircraft with emergency landing gear hand crank connected to main gear only.**

## LOWERING MAIN GEAR



1. Place the landing gear control lever on the pilot's control pedestal in the "DOWN" position.



2. Turn the emergency hand crank clockwise until the main gear is down and locked. (This requires approximately 30 turns.) The crank is on the forward side of the front spar and may be reached from the extreme forward end of the bomb bay catwalk.

**Note:** In case one gear comes down and locks before the other gear is locked, and the tightness of the cable to the locked gear prevents any further rotation of the hand crank, loosen the turnbuckle on the tight cable and continue cranking until the other gear is completely down and locked.



3. In addition to checking the landing gear warning light, check both wheels visually from waist gun windows to see that they are down and locked. (Flaps must be full up to permit this check.)

4. Return landing gear control lever to neutral.

**Re-setting Procedure**

To re-set the emergency lowering system, turn hand crank approximately 30 turns counterclockwise to normal position. Avoid cranking too far and allowing the cable to jump off the drums. Resafety the crank.

**LOWERING NOSE GEAR**

1. Place landing gear lever in the "DOWN" position.

2. Enter nosewheel compartment (on some aircraft it is necessary to remove the draft cur-



tain to get at the nose gear) and remove the butterfly pin (1) from its normal position.

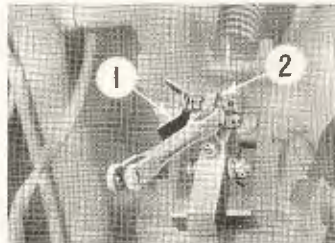

3. Insert the butterfly pin in the eye of the latch linkage (2).

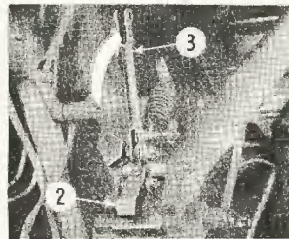

4. Release the nose gear latch by pushing up on the drag link (3).

5. Take a sitting position near the top of the shock strut. Grasp the top of the strut with both hands and lift upward to force the gear into the

RESTRICTED

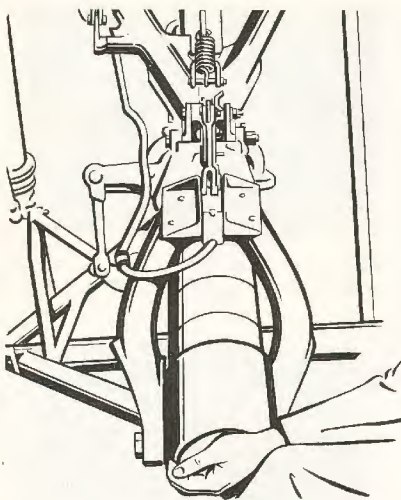

extended position. It may be necessary to rock the gear two or three times to get it moving. As the gear passes the center of balance, be careful to keep hands and arms clear of the gear assembly.



6. After the gear falls, make sure the lock is secure. If it is not securely locked, push upward on the lock assembly.

**Note:** Replace the butterfly pin as soon as possible after landing.

## MAIN GEAR FAILURES

**NOTE:** Try hydraulic operation several times before resorting to mechanical methods.

### A. Gear Fails to Lock Down

1. Hold landing gear selector valve down. If this fails to lock gears:

2. Accomplish locking by manual emergency method.

### B. Gear Jams While Lowering

1. Attempt to lower with hand crank emergency procedure. Be sure to place the gear selector valve in the "DOWN" position.

### C. Gear Jams While Raising

1. Lower and attempt to raise again.

2. If this fails, lower and land.

### D. Gear Fails to Lock in Up Position

1. Place landing gear selector valve in "UP" position and hold it there until gear locks.

2. If gear fails to lock after this is repeated several times, use hydraulic pressure to keep gear in the up position. If necessary, return selector valve to "UP" position frequently to prevent gear from slipping down too far. (Not recommended on long flights.)

### E. One Gear Sticks Up and Will Not Lower

1. Raise lowered gear and attempt to lower by emergency procedure. If this fails, land as described in "Landing With One Main Gear and Nose Gear Extended, One Main Gear Retracted."

### F. Gear Fails to Raise (No. 3 Engine Fails on Takeoff)

1. Turn the auxiliary hydraulic pump on. Switch is located on forward face of bulkhead No. 4.2, right side of fuselage.

2. Open emergency hydraulic (star) valve aft of Station 4.1, right side of fuselage.

## NOSE GEAR FAILURES

**Caution:** All men should be out of nose gear compartment while nose gear is being raised.

A. Gear Fails to Raise (No. 3 Engine or Hydraulic Pump Fails on Takeoff)

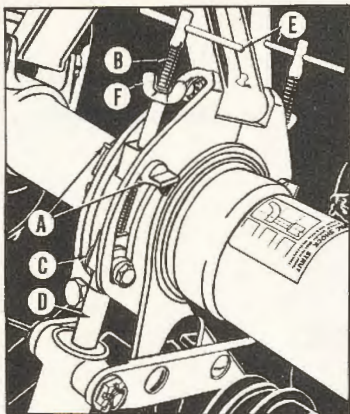

1. Turn on main switch for auxiliary hydraulic pump.

2. Open emergency hydraulic (star) valve.

**B. Gear Fails to Lower**

1. For early type B-24's check setting and safetizing of:

a. Emergency dump valve (slotted lever should be in vertical position).

b. Over-travel lock pin (pin must be in shallow grooves, **not** in deep slot). Pin is located under flight deck, Station 3.0, left side of fuselage.

2. Premature kick-out of landing gear selector valve:

a. Overpower until operation is completed.

b. On ground adjust pressures to 850 lb. sq. in. for "DOWN" and 1100 lb. sq. in. for "UP."

**C. Accumulator-Type Shimmy Damper Failure:** If nosewheel accumulator pressure falls below 150 lb. in flight, install emergency nosewheel lock before landing, as follows:

1. Remove valve cap on bottom of nosewheel accumulator and deflate accumulator completely.

2. Remove shoulder bolts "A" from locking screw assembly "B."

3. Place head of screw assembly "C" over end of damper shaft "D."

4. Force damper shaft into damper and insert two shoulder bolts "A" into block of screw assembly.

5. Repeat accumulator deflation operation (Step 1).

6. Repeat Steps 2, 3, and 4 for installing screw assembly on opposite side of nose gear.

7. Screw handles "E" in as far as possible.

8. Tighten wing nuts "F."

9. Extend nose gear and land.

**Caution:** Remove locks at end of landing roll and have airplane towed to parking area.

**D. Houdaille Shimmy Damper Failure**

1. There is no present means of locking this type of shimmy damper. In case of failure, make a nose-high landing just as if you had no brakes or had a damaged nosewheel.

**Caution:** Don't lower nose until airplane stops. Then lower gently and have the ship towed to parking area.

### EMERGENCY BOMB RELEASE SYSTEM

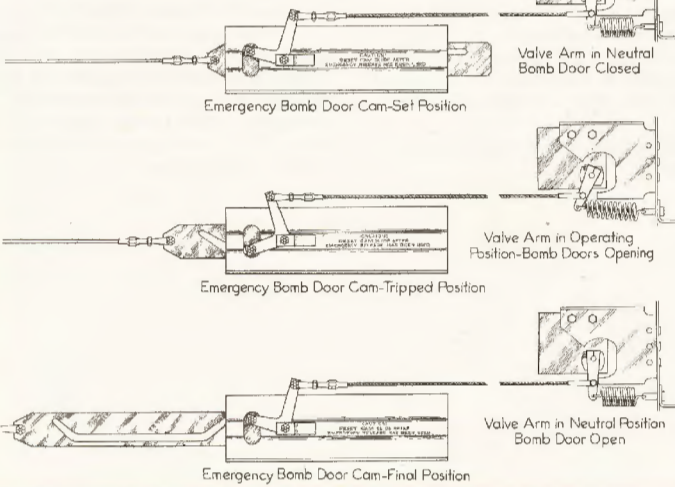
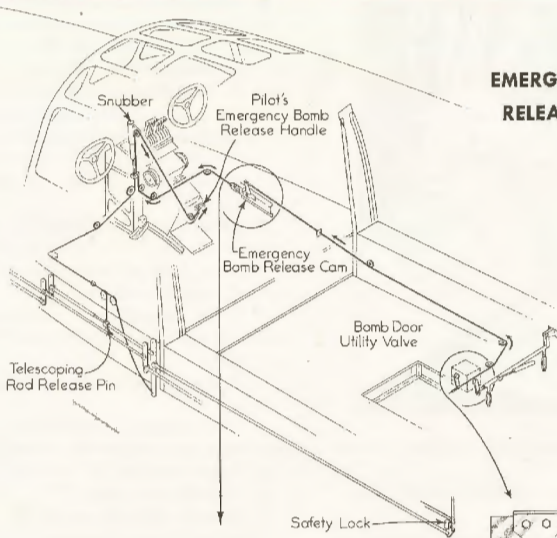

## EMERGENCY BOMB RELEASE OPERATION

### A. To Salvo Bombs

1. Pull pilot's emergency bomb release handle at rear of pedestal up approximately 4 inches, pause momentarily until bomb doors are completely opened (notice red light on instrument panel). Continue pulling upward to release bomb load.

### B. Re-setting Emergency Release

After emergency release of bombs by pilot, the system must be re-set in order to place bomb release system in operating condition and to close bomb bay doors. On late series aircraft, however, you can close bomb bay doors without re-setting the system.

1. Place release handle in socket on control pedestal.

2. In nosewheel compartment, take up slack in cable at cam located on right side of compartment between Stations 1.2 and 2.0.

3. Grasp cam at cable end and shove in until cable is tight, which allows bomb door utility valve to return to neutral position.

4. In the same compartment on left side of ship, between Stations 1.2 and 2.0, re-set emergency telescoping rod by replacing pin so that release system will function normally.

## EMERGENCY BOMB DOOR OPERATION

### A. To Open When Hydraulic System Fails

1. Move any bomb door release handle to "OPEN." (If you use bomb door emergency and utility (auxiliary) valve, under flight deck at Station 4, right side of fuselage, it must be held in "OPEN" position until procedure is completed.)

2. Pull hand cranks out of stowage clips, engage, and turn according to stenciled arrows on bulkhead. Location—Station 5.0, one crank on each side of catwalk.

### B. When Doors Open Partially and Stop

1. Check door tracks for possible obstructions.

2. Check bomb door mechanism, which might be out of alignment.

### C. When Doors Open Partially and Control Lever Returns to Neutral Position

1. Overpower selector valve until doors are open.

2. On ground adjust kick-out pressure of selector valve to 600 lb. sq. in. "OPEN," 1000 lb. sq. in. "CLOSED."

## Caution

**AT ALL TIMES STAY CLEAR OF  
BOMB BAY DOOR AREA WHEN  
DOORS ARE BEING OPERATED.**

## EMERGENCY WING FLAP OPERATION

### A. Emergency Hand Pump Operation (Located to Right of Copilot)

1. Place flap selector valve in "DOWN" position.

2. Break safety wire on needle valves with hand pump handle—then close forward valve and open aft valve.

3. Operate pump approximately 74 strokes or until pump locks to lower flaps, observing position of flaps on the indicator.

4. If indicator shows flaps down, but pump does not lock, investigate lines for leaks. Pump must lock or flaps will not be down and will creep up.

5. When flaps are completely lowered, return selector valve to neutral position.

### Before Flaps Can Again Be Operated Normally, the Following Must Be Done

1. Both the needle valves should be left open for approximately one minute to dissipate the pressure accumulated in the small emergency flap line, thus allowing the piston within the shuttle valve to return to normal position.

## RESTRICTED

2. If flaps cannot be raised, indicating shuttle valve sticking, put wing flap selector valve in "DOWN" position for a few seconds to break shuttle valve loose, and then return selector valve to neutral.

3. After this one-minute period the aft valve can be safetied in the closed position and the flaps operated normally.

### B. Failure of Engine-driven Pump Only

1. Turn on emergency hydraulic (star) valve.
2. Turn auxiliary hydraulic pump switch on.

### C. Premature Kick-out of Selector Valve

This is caused by too low a pressure setting or cold, congealed hydraulic fluid.

1. Overpower selector valve until operation is completed.

2. On ground adjust pressure settings to 750 lb. sq. in. for up operation, and 450 lb. sq. in. for down operation.

**Caution:** Do not lower flaps at speeds in excess of 155 mph IAS.

**NOTE:** Be sure both needle valves are open and flap selector valve is in neutral at same time. These valve settings then allow free passage of the fluid in the emergency line back to the reservoir.

# HYDRAULIC SYSTEM FAILURES

### A. Failure of Engine-driven Pump and Auxiliary Hydraulic Pump

Use emergency hand pump located to right of copilot's seat. Forward valve open; aft valve closed. This operates bomb bay doors, wing flaps, and landing gears by pumping fluid through unloading valve and open center system and it charges accumulators, thus providing pressure for brakes.

### B. Engine-driven Pump Fails to Operate

Open emergency hydraulic (star) valve and be sure auxiliary hydraulic pump switch is "ON."

### C. Hydraulic Lines Broken or Leaking

**Broken Lines:** To prevent loss of fluid temporarily, squeeze and fold back end of tubing with pliers.

**Broken Pressure Line (Right Wing Front Spar):**

1. Cut No. 3 engine and feather propeller immediately.
2. Disconnect line between suction check valve and engine-driven pump.
3. Turn on emergency hydraulic (star) valve and start auxiliary hydraulic pump.
4. Turn emergency reservoir valve to vertical position until reservoir can be replenished. Then return valve to normal, horizontal position.
5. Put No. 3 engine back into operation.

**Leaking Lines:** Excessive leaking can be remedied by tightening fittings with a tubing wrench. **Caution:** Do not tighten beyond safe limits.

### D. Unloading Valve Sticking in Flight

Cause: Foreign particles or broken spring.

1. Gently tap valve with mallet to give free movement of pistons.
2. In case of broken spring, the auxiliary hydraulic pump must be used to charge the accumulators.

### E. Hydro-electric Constant Pressure Switch Intermittently Cutting In and Out

Cause: Leak in accumulator or auxiliary pressure lines or faulty accumulator check valve. This condition should be corrected or it will result in fusing of points in switch.

1. Make certain emergency hydraulic (star) valve is tightly closed.
2. Check for possible leaks.

### F. Bomb Door Emergency and Utility Valve Fails to Return to Neutral, Causing Hydraulic System to Chatter Violently

Reach in under radio deck and return valve handle to neutral manually. Spring return is probably not working.

### G. Upper Part of Hydraulic Fluid Reservoir Leaking

Turn emergency reservoir handle (suction valve) to vertical position.

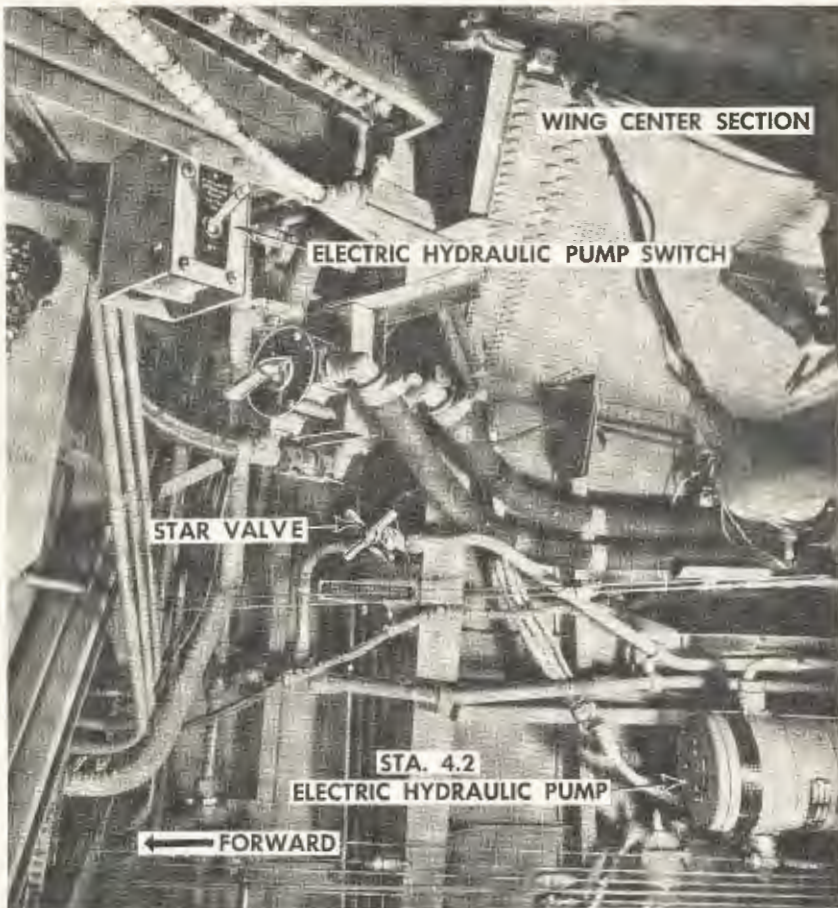

**Caution** If open center system pressure line on reservoir side of engine pump check valve is shot out, the system won't work except by hand-pump lowering of wing flaps and accumulator discharge.



RESTRICTED

## ELECTRICAL SYSTEM FAILURES

SYMPTOM	PROBABLE CAUSE	REMEDY
Autosyn instruments go dead.	<ol style="list-style-type: none"><li>1. Fuse blown.</li><li>2. Inverter trouble.</li><li>3. Inverter fuse blown.</li></ol>	<ol style="list-style-type: none"><li>1. Replace 2-ampere fuse in copilot's fuse box (at right of copilot).</li><li>2. Switch to other inverter.</li><li>3. Replace 30-ampere 51o-B1o fuse in copilot's fuse box.</li></ol>
Propeller feathering buttons do not work.	<ol style="list-style-type: none"><li>1. Circuit breaker holding circuit open or circuit is burned out.</li></ol>	<ol style="list-style-type: none"><li>1. Hold circuit breaker button down while operating feathering button. (Circuit breaker buttons are red buttons top of pedestal.)</li></ol>
Propellers feather and unfeather without stopping.	<ol style="list-style-type: none"><li>1. Pressure cut-out switch not working, or wire to it is grounded.</li></ol>	<ol style="list-style-type: none"><li>1. Pull feathering button out when propeller is fully feathered.</li></ol>
Propeller governor failure.	<ol style="list-style-type: none"><li>1. Fuse blown.</li></ol>	<ol style="list-style-type: none"><li>1. Replace 10-ampere fuse in pilot's fuse box (left of pilot). Do <u>not</u> flip switch back and forth quickly.</li></ol>
Hydraulic gages show no pressure.	<ol style="list-style-type: none"><li>1. No. 3 engine pump not working.</li></ol>	<ol style="list-style-type: none"><li>1. Turn on toggle switch for auxiliary hydraulic motor—in right front bomb bay on crossbar high up—large toggle switch.</li></ol>
Landing gear down lamp (green) does not light.	<ol style="list-style-type: none"><li>1. Bulb burned out.</li><li>2. Fuse blown.</li><li>3. Micro switches not working.</li></ol>	<ol style="list-style-type: none"><li>1. Replace with spare on panel near light.</li><li>2. Replace 10-ampere fuse in fuse box.</li><li>3. Have crew member visually check to see, first, if nosewheel is down and latched; then if main wheels are down and locked.</li></ol>
Interphone dead.	<ol style="list-style-type: none"><li>1. Fuse blown.</li></ol>	<ol style="list-style-type: none"><li>1. Replace 10-ampere fuse in liaison junction box, right side under radio table.</li></ol>
Radio compass receiver dead.	<ol style="list-style-type: none"><li>1. Fuse blown.</li><li>2. Inverter fuse blown.</li><li>3. Inverter trouble.</li></ol>	<ol style="list-style-type: none"><li>1. Replace blown 5 or 10-ampere fuse (or both) in radio compass splice box on aft support of radio compass unit, and 5-ampere fuse in copilot's fuse box.</li><li>2. Replace 30-ampere 51o-B1o fuse in copilot's fuse box.</li><li>3. Switch to other inverter—switch on pedestal, lower left side. Also check inverter relay in box near inverter under flight deck.</li></ol>

SYMPTOM	PROBABLE CAUSE	REMEDY
Command radio receiver dead.	1. Fuse blown.	1. Replace fuse at modulator dynamotor unit. (There are two 20-ampere fuses under removable covers on the base, with spares on the opposite side.)
Liaison radio transmitter dead.	1. Fuse blown.	1. Warning: Turn switch off first. Voltage in this unit is dangerously high. Replace power fuse—there are 2 cartridge-type fuses, one 30 and one 60 ampere, and a 1000-volt fuse in the output circuit of the liaison dynamotor at rear right of radio compartment. Remove cover to reach fuses. Liaison transmitter 1000-volt fuse is reached by removing tuning coil section. Fuses are inside and above space for tuning unit.
Liaison receiver dead.	1. Fuse blown.	1. Replace fuse. Remove 2 knurled nuts on front of receiver and slide out receiver; 5-ampere fuse is on lower right hand side. There are no spares in receiver. (Receiver is normally sealed.)
Bombing interval control dead.	1. Fuse blown. 2. Interval control defective.	1. Replace 15-ampere fuse inside bomber's panel. 2. Remove interval control plug and release bombs manually.
Cannot release bombs electrically.	1. Bomb door switches open. 2. Voltage too low.	1. Check bomb doors—must be full open. Check fuse in Station 4.0 fuse box. 2. Check voltage at power panel on rear bulkhead of flight deck. If low (below 24 volts) cut off all possible electrical equipment. See item below.
Lights dim.	} DC Voltage Low {	} 1. Check voltage of each generator at power panel. 2. Switch off any dead generator. 3. Switch off all electrical units not absolutely necessary. 4. Start auxiliary power supply unit. Equalizer switch may be turned on if engine generators are working. 5. Look for and switch off any electrical unit damaged, shorted, heating badly or obviously defective. 6. Adjust voltage regulators to maximum.
Motors slow to start.		
Motors noisy.		
Interphone weak.		
Radios weak or dead.		
Inverter power weak and inverter action erratic.		
Bomb release interval control dead.		

RESTRICTED

# BAILOUT DITCHING AND FIRES



## BAILING OUT OF THE B-24

It is the responsibility of the airplane commander to make certain on every flight:

1. That a parachute is available and satisfactorily fitted for each person making the flight.

2. That the parachute is conveniently located at the normal position of the person making the flight and that he knows its location, how to put it on, how and where to leave the airplane, how to open the chute and how to land and collapse the chute. (See P.I.F.)

3. That a life vest is worn under the chute harness on all over-water flights and that the crew knows the location, how to attach and how to use the individual seat-type life raft.

4. That all persons aboard know the bailout signals and the bailout procedure to be followed.

The easiest and most effective way to carry out this responsibility is to appoint a parachute officer (usually the engineer) who will make a special study of equipment, its use, approved bailout signals, and the proper method of leaving the airplane. He will assist in conducting bailout drill once each week on the ground until the entire crew is proficient, and as often thereafter as necessary to keep the crew conscious of the proper care and wearing of equipment.

Such drill only takes a few minutes at the conclusion of a practice mission.

#### When to Bail Out

In all cases it is the positive responsibility of the airplane commander to decide when a bail-out emergency exists. Never shirk your responsibility by putting it up to the crew. In case of fire, fuel exhaustion, mid-air collision, weather which makes a landing dangerous, or other hazardous circumstances only you, the airplane commander, can judge the extent of the danger and whether or not the crew should bail out.

#### Radio Your Position

The instant you suspect an emergency is developing, get your position from the navigator and have the radio operator broadcast your position and your difficulty. This may save hours or even days for rescue parties searching for you.

#### Bailout Signals

(Check to be sure all crew members can hear the alarm bell in flight.)

**Prepare to Bail Out:** Three short rings on the alarm bell. Also warn the crew by interphone and obtain acknowledgment from each crew member.

**Bail Out of the Airplane:** One long sustained ring.

**Don't Bail Out:** If you have given the signal "Prepare to bail out," don't hit the bell again or the boys will all leave. If you want to call off the emergency, send the engineer to do it or notify crew members by interphone. Where pilots have used a series of short rings to call off the emergency, half the crew have in some cases hit the silk.

#### Bailout Procedure

1. At the signal "Prepare to bail out," all the crew will acknowledge by interphone and make immediate preparations to leave the ship, checking parachute snaps and attaching the quick attachable-type chute if so equipped.
2. Pilot or bombardier (at pilot's direction) will open the bomb bay doors and jettison bombs to provide clearance for jumping; navi-



Leaving  
Through the  
Bomb Bay



Leaving  
Through the  
Nosewheel  
Hatch

RESTRICTED



Leaving  
Through  
Belly Hatch



Legs Together  
And Straight  
When Clear  
Of The Ship



gator will open the nosewheel hatch by pulling down on the 2 red handles at Station 1.0 on the cross-member under navigator's table; tail gunner opens belly hatch. These are the 3 best bailout exits.

3. Crew should check each other's equipment to be sure it is properly fastened and attached.

4. Pilot slows airplane down to 150 mph (to 140 mph with 20° of flaps) before giving bailout signal.

5. Exits for bailout:

a. Navigator and bombardier (nose turret gunner) leave through the nosewheel hatch one after the other, facing front of ship, crouching near opening with hands on each side and rolling out headfirst.

b. Tail gunner and left waist gunner exit through belly hatch from a crouching position facing the direction of flight.

c. Ball turret gunner and right waist gunner leave through rear bomb bay; flight engineer, radio operator, copilot, and pilot also leave through the bomb bays, crouching on the catwalk facing the direction of flight.

**Warning:** It is extremely important in all cases to face the front of a B-24 and roll out headfirst. The airplane is traveling fast, and if you jump toward the rear there is danger of being slapped up against the airplane. If you jump feet first, the wind can catch your legs and bang your head on the edge of the hatch.

6. Don't pull the ripcord until you have straightened your legs and are well clear of the airplane, unless bailing out at a low altitude. See P.I.F. for instructions on how to fall and how to land under various circumstances.

## DITCHING THE B-24

Ditching drill is the responsibility of the pilot. Duties should be studied, altered if necessary to agree with any modifications, memorized, and practiced until each crew member performs instinctively.

The moment a ditching emergency arises the pilot gives the signal for crew to take ditching positions, the altitude, and the approximate number of minutes before impact. This should be acknowledged by the crew in this order: copilot, navigator, bombardier, nose gunner,\* flight engineer, radio operator, right waist gunner, left waist gunner, belly gunner, and tail gunner, with the words, "Copilot ditching, navigator ditching," etc.

### Alarm Bell Ditching Signals:

1. Crew to ditching positions—6 short rings.
2. Brace for ditching—1 long ring just before impact.

### Procedure

Immediately, all crew members should remove ties and loosen shirt collars and remove oxygen masks unless above 12,000 feet, in which case oxygen continues to be used until notification by the pilot.

All crew members wearing winter flying boots should remove them, but remove no other clothing. Then each crew member performs his specific duties. Have life vests on but do not inflate them before exit from airplane.

Upon warning to ditch, crew members will remove parachutes and parachute harness.

\*Ten-man crew would have only one waist gunner if it has a nose gunner. All positions are mentioned as a guide. Each airplane commander will have to adapt procedures to his particular needs and equipment.

### Duties Before Landing on Water

**Pilot:** After giving the warning he remains in the normal flight position for ditching. Fastens safety belt and shoulder harness but unfastens parachute straps. Shortly before impact, he gives a long ring on the alarm bell to notify the crew to brace for ditching.

**Copilot:** Remains in normal flight position. Unfastens parachute straps and fastens safety belt and shoulder harness. Assists pilot as necessary.

**Navigator:** Calculates position, course, speed, and estimated position of ditching and gives information to radio operator. Destroys secret papers. Gathers maps, compass, and celestial equipment. Goes to flight deck and takes ditching position.

**Bombardier:** Jettisons bombs and closes bomb doors. Destroys bombsight. Goes to rear compartment, checks position of others and takes ditching position.

**Nose Gunner:** Jettisons ammunition, locks nose turret in forward position, and goes to ditching position.

**Flight Engineer:** Turns guns aft. Shoots out or jettisons ammunition. Avoid getting shell cases jammed in the bomb doors. Opens and removes top hatch and jettisons it and loose equipment through the bomb bay and checks to see that it is closed. Closes floor door and rear door to flight deck after navigator comes up. Takes ditching position.

**Radio Operator:** Turns IFF to distress, switches on liaison transmitter (turned to MF DF frequency) sends SOS, position, and call sign continuously. On order from the pilot he clamps down key, hinges up radio table and takes ditching position.

**Left Waist Gunner:** Opens left waist window and leaves it open, jettisons left waist gun, ammunition and all loose equipment, preferably through the belly hatch to avoid damaging tail surfaces. Takes ditching position.

**Right Waist Gunner:** Opens right waist window and leaves it open. Jettisons right waist gun, ammunition and loose equipment, preferably through the belly hatch to avoid damaging tail surfaces. Goes to ditching position and remains on interphone.

## RESTRICTED

**Belly Gunner:** Retracts ball turret and jettisons ammunition, preferably through belly hatch if time permits. Takes ditching position.

**Tail Gunner:** Lines up turret directly aft and locks. Comes out of tail, helps jettison ammunition and check belly hatch firmly closed. Takes ditching position.

A crew member and an alternate will be designated by the pilot before flight to take the emergency radio transmitter and all other emergency equipment to the radio room before ditching and will be responsible for getting this equipment to the life raft.

**Warning:** If time permits, waist windows should be removed and jettisoned through the belly hatch to avoid danger of their closing and jamming shut on impact. It is most important that all bottom hatches be closed and that the top hatch and waist windows be open.

### Ditching Positions

It is impossible to specify ditching positions which will apply to every B-24 crew as location of equipment in the airplane will vary as well as crew composition. Each pilot with the help of the following information should assign definite braced positions for each of his crew members which will apply to the airplane he is flying. Crew members should use cushions and parachutes to help cushion the shock of impact and to protect the head from flying debris.

The command deck which is located above the bomb bay has proven itself the best possible ditching station in the airplane. As many crew members as possible should take up ditching positions at this station. Your airplane may have one of the two types of ditching belts on the command deck:

1. A single belt to be mounted across the fuselage with crew positions as follows:

a. Five men seated in belt facing aft, hands behind head.

b. Two additional men seated in front of the five men braced against their legs, facing aft, hands behind head (the belt is stressed for seven men).

2. A set of three short belts in tandem with crew positions as follows:

a. One man in the forward belt facing aft,

hands behind head.

b. Two men in the middle belt facing aft, hands behind head.

c. Two men in rear belt facing aft, hands behind head.

3. If your airplane is not equipped with a ditching belt, crew members will lie down, back to the floor, feet in direction of flight with knees flexed or sit facing aft, back braced against a bulkhead or another man's legs. The best exit is the hatch above command deck but waist windows may be used as alternate exit.

On the flight deck the pilot and copilot will ditch in their seats with safety belt and harness fastened. Possible ditching positions for crew not able to ditch on the command deck are as follows:

a. Standing behind pilot's seat with back braced against armor plate or canvas bulkhead, hands braced against sill of open hatch (two men can brace here side by side if necessary).

b. Standing behind copilot's seat back braced against armor plate or canvas bulkhead, hands braced against ceiling.

Approved ditching positions have been published showing men sitting on the floor of the flight deck. However, subsequent reports indicate that a standing position is preferable to avoid injury from the top turret which often comes down on impact. Exits on the flight deck are top hatch and pilot's and copilot's windows.

4. The waist is the least desirable ditching station and should only be used if the command deck is not available. If it becomes necessary to use the waist the following positions are recommended:

a. Braced against ditching belts if provided.

b. The linked arm position.

First man; seated on left side of waist, facing forward, feet against turret step, knees slightly flexed.

Second man; on right side of first man, same posture.

Third man; seated facing the left window behind the first man, feet against the fuselage, knees bent.

Fourth man; on the left side of the third

man, same posture.

Fifth man; seated facing the right window behind the second man, feet braced against the fuselage, knees bent.

Sixth man; on right side of the fifth man, same posture. All six men link arms.

c. The strength of the positioning is in leg bracing and arm linking. This can only be learned in ditching drill.

d. The position loses strength as the numbers are reduced but is considered efficient down to four men.

**Approach and Touchdown**

Pilot determines direction of approach well in advance. Touchdown parallel to lines of crests and troughs in winds up to 35 mph. Ditch into wind only if wind is over 35 mph or if there are no swells. Use flaps in proportion to power available to obtain minimum safe forward speed with minimum rate of descent. In every case try to ditch while power is still available. Touchdown in a normal landing attitude. Severe decelerations and several impacts may be expected, so warn your crew not to move until the airplane has come to rest.

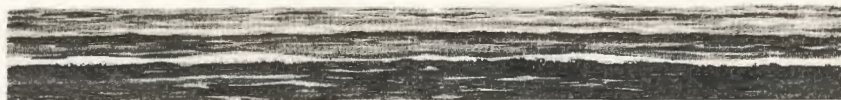

**HOW TO DETERMINE WIND SPEED**

A few white crests.....10 to 20 mph  
 Many white crests.....20 to 30 mph

Foam streaks on water.....30 to 40 mph  
 Spray from crests.....40 to 50 mph



## RESTRICTED

### Procedure After Landing

When the airplane has come to rest, engineer will pull releases on life rafts. Exits will be made as follows:

**Pilot:** exits through flight deck hatch, goes to left life raft.

**Copilot:** exits through flight deck hatch, goes to right life raft.

**Navigator:** exits through flight deck hatch, goes to left life raft.

**Engineer:** exits through flight deck hatch, goes to right life raft.

**Radio Operator:** Exits through flight deck hatch, goes to left life raft.

**Right Waist Gunner:** exits through rear hatch, goes to right life raft.

**Belly Gunner:** exits through rear hatch, goes to left life raft.

**Bombardier:** exits through rear hatch, goes to right life raft.

**Left Waist Gunner:** exits through rear hatch, goes to left life raft.

**Tail Gunner:** exits through rear hatch, goes to left life raft.

Pilot and copilot will take command each of his life raft, call roll, and check survival equipment if time permits before life rafts are cut loose from the airplane.

**Note:** If time and circumstances permit, take out the frequency meter and be sure to keep it dry. By attaching antenna from the Gibson Girl emergency radio to frequency meter, it can be operated as an efficient receiver to provide 2-way communication for several hours.

### The Time Element

Speed is important, but so is procedure. Give first attention to injured persons. Don't leave necessary equipment behind or you will face starvation and have no means of signaling for help. Drill to get maximum teamwork.

### Survival

Pilot should study P.I.F. and survival booklets and instruct crew so all will know how to make the most of life raft equipment, how to signal, and how to survive on the sea.

# FIRES



## ENGINE FIRE ON GROUND

If fire occurs as engine is starting, keep engine running in an effort to blow out fire, or to suck fire into the induction system. If fire persists, or engine does not start:

Pilot will:

1. Give command "Extinguish fire in No. . . . engine."
2. Place throttle in full open position.
3. Put mixture controls in "IDLE CUT-OFF."

Copilot will:

1. Turn off fuel booster pump.
2. Turn off all engine ignition switches to protect ground personnel.
3. Place carbon dioxide (CO<sub>2</sub>) selector valve in position for engine affected.
4. Pull fire extinguisher release handle if fireman standing by cannot control fire.
5. Pull release handle, opening remaining CO<sub>2</sub> bottle, if fire persists.

Engineer will:

1. Turn off fuel selector valve of affected engine.
  2. Obtain CO<sub>2</sub> bottle from flight deck and assist fireman standing by for starting engines.
- Fireman will:

1. Direct CO<sub>2</sub> at base of fire. When fire in accessory compartment resists other means of

RESTRICTED

RESTRICTED

control, open the starter access door and direct CO<sub>2</sub> nozzle toward base of flame, if possible.

Do not risk personal injury by attacking fire before propellers are stopped or by attacking fire from top of wing or nacelle; heat and flame rise.

Radioman will:

1. Stand by to aid in determining source of trouble and correcting it.

## ELECTRICAL FIRE ON GROUND

Pilot will:

1. Give command "Extinguish electrical fire in . . . (location)."
2. Stop engines by placing mixture controls in "IDLE CUT-OFF."

Copilot will:

1. Place battery and main line switch in "OFF" position.
2. Turn off fuel booster pump.

Engineer will:

1. Determine that all sources of electrical power are off, including generators, auxiliary power unit or battery cart.
2. Turn valve off on sight fuel gauges.
3. Proceed to scene of fire with CO<sub>2</sub> bottle from flight deck and direct same at base of fire.

Radioman will:

1. Stand by to aid in determining source of trouble and correcting it.

**Note:** If fire persists, copilot will leave airplane to summon outside aid.



## OTHER FIRES ON GROUND

Pilot will:

1. Give command "Extinguish fire in . . . (location)."
2. Stop engines by placing mixture controls in "IDLE CUT-OFF."

217

## RESTRICTED

Copilot will:

1. Turn booster pumps off.
2. Turn main line switch off.
3. Proceed to scene of fire with CO<sub>2</sub> bottle from flight deck and direct same at base of fire.

Engineer will:

1. Turn fuel selector valves and fuel sight gauge valve off.
2. Obtain second CO<sub>2</sub> bottle from rear of airplane and aid copilot in extinguishing fire.

Radioman will:

1. Contact local control tower and request aid of fire truck, upon pilot's orders.
2. Go to scene of fire to assist in moving cargo or rendering other aid.

Note: If fire persists, copilot will leave airplane to summon outside aid.

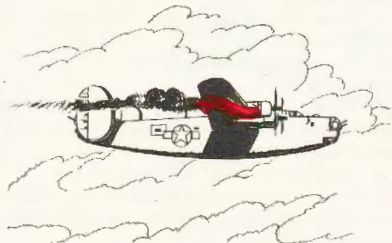

### ENGINE FIRE IN AIR

Pilot will:

1. Give command "Extinguish fire in No. ... engine."
2. Order engineer to turn off fuel selector valve.
3. Feather propeller of affected engine and place mixture control in "IDLE CUT-OFF" when fuel in lines has been exhausted and fuel pressure has dropped to zero.
4. Warn crew to be ready to bail out if necessary.

Copilot will:

1. Open cowl flaps and check booster pump in "OFF" position.
2. Place selector valve of engine fire extinguisher (panel on flight deck to right of copilot's seat) to position for engine affected (if CO<sub>2</sub> system is aboard). Other selector valve in "OFF" position.

3. Pull the CO<sub>2</sub> release valve handle of one bottle.

4. Pull second release handle, opening remaining CO<sub>2</sub> bottle, if fire persists.

Engineer will:

1. Immediately place fuel selector valve in "OFF" position for engine affected.
2. Open bailout hatches if condition is serious.

Navigator will:

1. Determine location of airplane at time of fire if distress signals are to be sent.

Radioman will:

1. Stand by to send distress messages.

### ELECTRICAL FIRES IN AIR

Pilot will:

1. Give command "Extinguish electrical fire in ... (location)."
2. Warn crew to be ready to bail out if necessary.

Copilot will:

1. Place battery switches in "OFF" position (not the main line).

Note: No lights or engine instruments will operate under this condition. Flashlights must be kept on hand at all times during night flights.

Engineer will:

1. Place all generator switches in "OFF" position.
2. Make certain auxiliary power unit is off.
3. Obtain CO<sub>2</sub> hand fire extinguisher and direct it at base of fire.

Navigator will:

1. Assist engineer at location of fire.

Radioman will:

1. Assist engineer at location of fire.

### OTHER FIRES IN AIR

Pilot will:

1. Give command "Extinguish fire in ... (location)."
2. Warn crew to be ready to bail out if necessary.

Copilot will:

1. Turn off all heater switches and valves.
2. Proceed with flight engineer to scene of

fire, obtaining if possible, second CO<sub>2</sub> bottle from rear of airplane.

Engineer will:

1. Proceed to scene of fire with CO<sub>2</sub> bottle from flight deck.

2. Open escape hatches if condition is serious enough to prepare to abandon plane.

Navigator will:

1. Determine location of aircraft at time of fire if distress signals are to be sent.

2. Act as liaison between crew members, etc.

Radioman will:

1. Stand by to send distress messages.

2. Assist engineer at scene of fire with pilot's permission.

## EFFECTS OF CARBON DIOXIDE AND CARBON TETRACHLORIDE FUMES

### Carbon Dioxide

Carbon dioxide (CO<sub>2</sub>) is a non-poisonous gas and breathing it will not adversely affect a human being either at the time it is inhaled or afterwards. If the concentration of CO<sub>2</sub> gas is high enough, it will have a smothering effect, through the exclusion of oxygen, but the quantity of carbon dioxide gas contained in a hand extinguisher installed in aircraft is not sufficient to raise the concentration in an airplane cabin to this point.

### Carbon Tetrachloride

Carbon tetrachloride is a volatile fluid, the gases of which when inhaled in large amounts act as an anesthetic, causing drowsiness, dizziness, headache, excitement, anesthesia, or sleep. One or more of these symptoms may occur. If small doses of the fumes should be breathed in over a period of time the first probable effect would be drowsiness followed by sleep or perhaps headache and nausea.

If any odor of carbon tetrachloride is detected while flying, an investigation to determine its source should be made immediately. If it is found that a fire extinguisher is leaking, it should be corrected at once or the extinguisher should be placed where it will not leak in the cabin.

**Caution:** Carbon tetrachloride is poisonous if taken internally. Even ¼ of a teaspoonful

may prove fatal. Symptoms of poisoning do not appear for several days after the fluid is taken into the stomach, thus giving a false sense of security. Anyone who accidentally ingests some of the fluid should report to the surgeon immediately for advice and necessary treatment.

**Warning:** In the presence of a flame, carbon tetrachloride produces a poisonous gas. When sprayed on a fire, carbon tetrachloride produces phosgene, one of the poisonous gases used during World War I. Inhaling even a small amount under such conditions may produce harmful effects and, if a sufficient quantity is taken into the lung, the result may be fatal. Avoid breathing the fumes when using the fluid on a fire.

## FIRE EXTINGUISHER SYSTEM

### Engine Fire Extinguisher CO<sub>2</sub>

There are 2 panels on the floor outboard of the copilot. Each panel has a 2-way engine selector valve by means of which the gas can be directed to either of 2 engines, and a pull handle which opens the flow from the CO<sub>2</sub> cylinders. Either or both CO<sub>2</sub> cylinders may be used to discharge through either panel. Thus, when one cylinder is exhausted, the other cylinder may be used as a source of supply for any engine. A perforated tubing ring around the engine nacelle discharges CO<sub>2</sub> into the engine area.

**Note:** The 2 engine system bottles will empty overboard if prematurely discharged by built-up pressure. A break in the red seal in the skin on the right side of the nose is then visible **from the outside only** at Station 3.0. Make sure the safety wire on the pull handle is unbroken.

### Hand Extinguishers

**Inside**—On aircraft up through 42-40137, one CO<sub>2</sub> bottle is behind the pilot and one is at Station 6.0. From 42-40138 through 42-72864, another CO<sub>2</sub> bottle is added at Station 1.0 above navigator's map case. From 42-72865 and on, only one CO<sub>2</sub> bottle is provided, located behind the pilot.

Two carbon tetrachloride hand extinguishers are available from the outside through easily recognizable red doors and from the inside through zipper coverings. One is on the left side of the fuselage near the jack pad, and the other on the right side aft of the bomb bay.

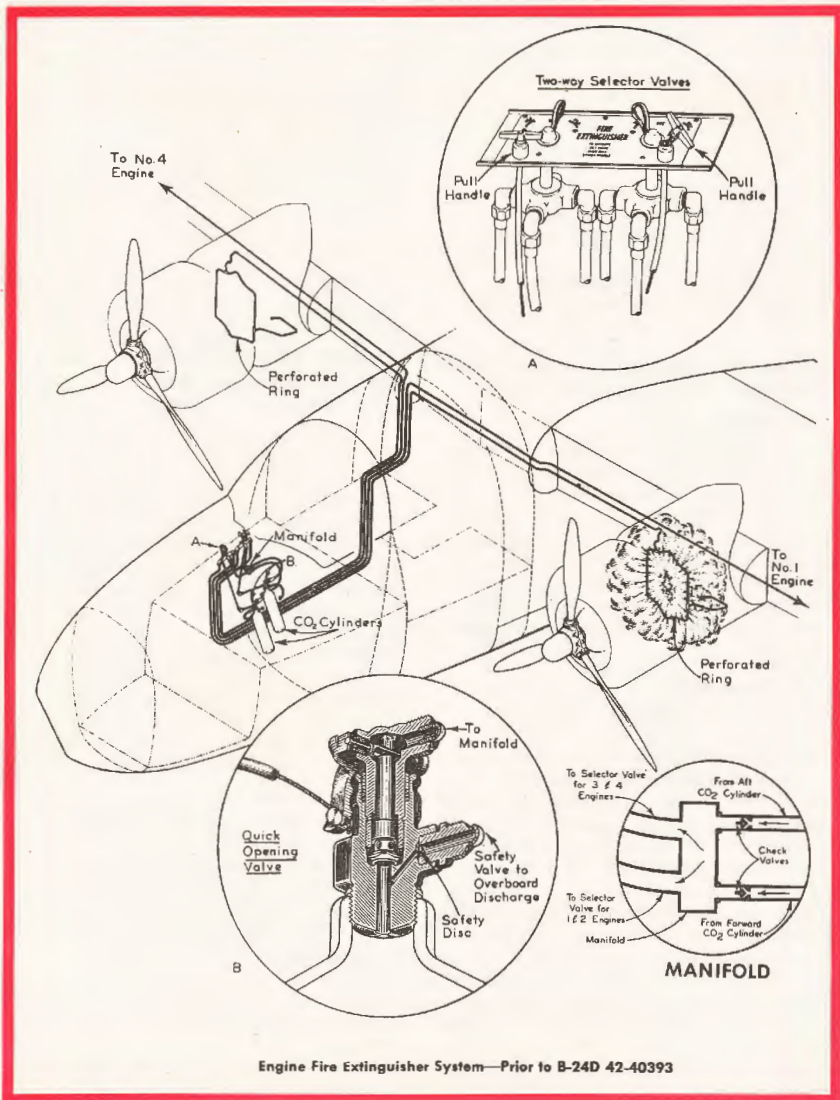

## FLARES AND PYROTECHNICS



### Flares

Flare ejector tube is located on the left of the center line of the airplane immediately forward of entrance door, between Stations 7.2 and 7.3.

### To Load a Flare

Move operating handle downward. This rotates cam so that flare can enter tube. Insert the flare to the proper position where cam enters the slot in the side of the flare casing. Connect the flare safety to the fish line on reel.

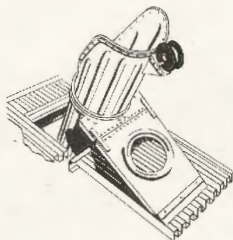

### To Eject a Flare

The flare tube is fitted with 2 controls; one a toggle handle located on the inboard side of the tube which opens the door in the bottom of the fuselage uncovering the flare tube, and the second a handle located on the aft side of the flare tube which is the flare handle.

### Pyrotechnics

The pyrotechnic installation located on the left side of flight deck between Stations 3.0 and 4.0 consists of:

- 1 Type M-2 signal pistol
- 1 Type A-1 portable signal container
- 9 Type M-10, M-11 signals
- 1 Type A-1 holder, pyrotechnic pistol

On B-24D aircraft Serial No. 41-23640 and on, stowage has been changed to the rear compartment, right side, between Stations 7.4 and 7.5.

RESTRICTED



## NIGHT FLYING

Night flying the B-24 is very much like day flying because in each case you fly the airplane very largely by reference to instruments. Difficulties in almost every case are traceable to failure on the part of the airplane commander to make allowances for the fact that the sun doesn't shine at night. You must faithfully perform all procedures necessary in day flying plus others made necessary by the fact that it is dark. Following is a list of practical suggestions that make night flying easier and safer.

### Night Inspection

Don't neglect your inspection of the airplane and crew. Trouble at night is double trouble. Perform your exterior inspection with a flashlight and with extra care. There is a greater

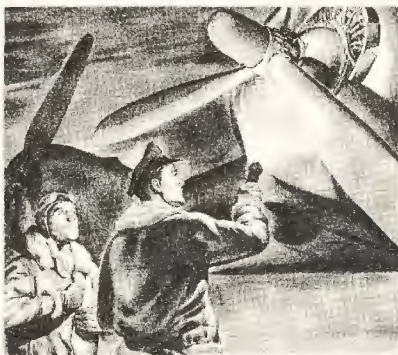

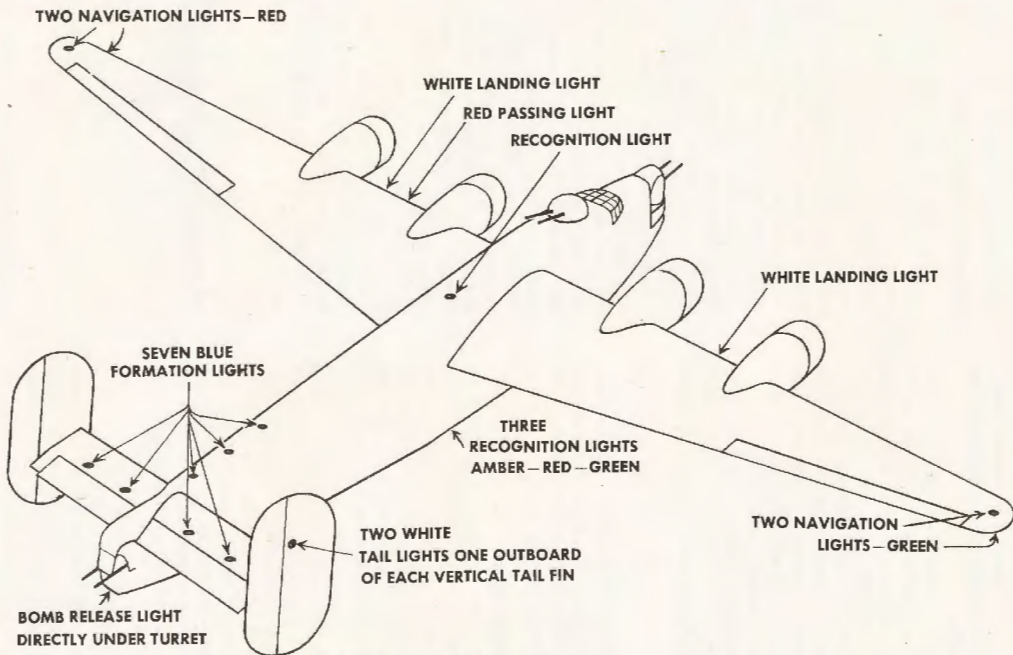

WHITE LIGHT GOES ON WHEN THE BOMB DOORS HAVE BEEN FULLY OPENED  
RED GOES ON DURING BOMB RELEASE PERIOD



## RESTRICTED

chance that the engineer may have missed something. Make sure the crew is fully and properly equipped. **Make it an ironclad rule to have an extra flashlight aboard with extra batteries and bulbs.**

While you are making the exterior inspection, have the engineer turn on the master switch, battery selector switches, and the radio operator's cockpit light. Then you can use compartment light to aid the interior inspection.

Remember that a surplus supply of fuel and oxygen is doubly important at night when your flight can be unexpectedly prolonged because of navigation or weather difficulties.

Always specifically question the radio operator to make certain that radio equipment is in top condition. Radio failure at night is a serious hazard.

### Checklist

Use the checklist. It's easier to overlook something at night than in the daytime because even the best light casts shadows and gives the cockpit a different appearance.

### Instrument Panel Lights

Two different types of lights are used to illuminate the instrument panels of B-24's: the tube-type and spotlight-type fluorescents. The spotlight type uses direct current (DC) and can be turned on as soon as you are seated. The tube type uses alternating current (AC) and must be turned on after AC power is on, just before starting engines. In each case there are 4 panel lights equipped with individual rheostat control and with filters which should be adjusted for minimum glare and maximum fluorescent illumination. Proper adjustment of filters will greatly increase the ease and speed with which you can read instruments. After your AC power is on, turn on your compass light (AC rheostat control).

### Check Exterior Lights

Without exterior lights, the B-24 is a big roaring hunk of darkness. If a running light is out, other aircraft can't tell whether your airplane is coming, going, or standing still. Learn the purpose and use of exterior lights and have the engineer see that all are in good working order.

The best time make this check is during the visual control check. Have the ground crew check all lights the engineer can't see.

### Purpose of Exterior Lights

1. **Running or Position Lights:** These 6 lights consist of 2 green starboard lights, one on top and one beneath the right wingtip; 2 red port lights, one on top and one beneath the left wingtip; and 2 white tail lights, one outboard of each vertical tail fin. These mark the extremities of the airplane and show which way it is moving through the darkness. They are controlled by a toggle switch on the pilot's pedestal.

2. **Passing Light:** This is a red spotlight located between No. 1 and 2 engines. It may be left on or turned on when in the vicinity of other aircraft to give notice of your position.

3. **Recognition Lights:** There are 4 of these, one (white) located on top of the fuselage above the bomb bays and 3 (amber, red, and green) sunk into the fuselage skin beneath the bomb bay catwalk. There is a separate 3-position toggle switch for each light, positions "ON," "BLINK," and "OFF." In the blink position, a telegraph key can be used for blinking the color of the day when operating in combat zones, or for code signaling. Various combinations of colors and signals make it possible to vary the code as frequently as desired.

4. **Formation Lights:** These 7 blue lights are located on top of the empennage to aid in formation flying. They form a perfect "T" on which other airplanes can guide in night formation flying.

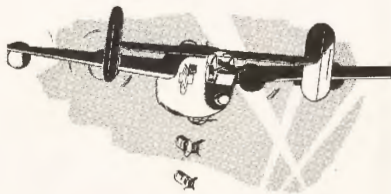

5. **Bomb Release Lights:** These are located at the extreme aft end of the plane under the tail turret. The white light goes on when the

bomb doors have been fully opened. The white light goes out and the red light goes on during the bomb release period; it is extinguished 5 seconds after the last bomb has dropped. This gives warning and protection to other airplanes in your formation. In training, these lights are sometimes wired to remain on all the time.

6. Landing Lights: The 2 landing lights are located just inboard of the wheel wells with separate toggle switches for each. They are extremely powerful and produce terrific heat confined in a small space. When the plane is flying, this heat is dissipated rapidly, but on the ground it can quickly burn out the bulb, especially in warmer climates. Never leave them burning for over 3 minutes when the plane is on the ground.

#### Taxiing at Night

1. Follow all daytime procedures with extra care. Be sure the flight indicator and directional gyro are working perfectly. You'll rely on them more than ever.

2. Turn off all inside white lights for taxiing. Use both landing lights while taxiing in close quarters but turn off one as soon as possible and then switch back and forth from one to the other every one to two minutes to avoid overheating. Make turns with the inside landing light on.

3. Post an observer with his head out the flight deck hatch. Clear congested areas with a man on each wingtip and one out in front.

**Warning:** Use extraordinary precautions. You can't see your wingtips and obstructions are concealed. Don't go off the runway, or ram parked aircraft.

4. If in doubt, ask the tower where to turn. It will keep you from ending up in a mudhole or on some strange main street.

5. Remember there are other aircraft around. Get radio clearance from the tower for crossing runways. If taxiing toward a landing runway, retract your landing lights to keep from blinding incoming pilots. When you get in position for run-up, turn off your landing lights to save batteries and avoid overheating.

#### Run-up

Your run-up is the same as in the daytime, but you have the problem of interior lighting. Be sure and have a red filter on the radio operator's light, or the white light will impair your night vision. Use a filtered flashlight to further aid your run-up check. Always make sure crew are in proper positions for takeoffs and landings and that one crew member in rear compartment is on interphone.

#### Takeoff

Make certain of your radio clearance to the takeoff runway and check for incoming airplanes. As you turn into position for takeoff be sure that you are lined up straight with the runway lights and that the nosewheel is straight.

Landing lights should be used or not in accordance with local requirements. However always flash both lights down the runway long enough to make certain that the way is clear. Fatal accidents have resulted from failure to do this.

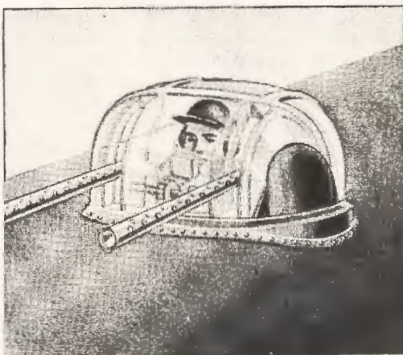

**Top Turret Observer:** Where possible put a man in this position during landings, takeoffs, and traffic flying to observe and report all traffic by interphone.

## RESTRICTED

Stay down the runway by combining the use of the directional gyro and reference to the runway lights after you get rolling. Three instruments govern your takeoff: directional gyro, flight indicator and airspeed indicator. Be particularly careful not to hurry the airplane off the ground at night. If you have plenty of runway, get 5 to 10 mph extra flying speed (especially if heavily loaded) and let the airplane fly itself off, judging your attitude by the flight indicator. Hold to your rate of climb, your airspeed and your gyro heading. After you leave the runway it is easy to get into a turn if you don't follow your directional gyro and flight indicator. Don't lower the nose so that the miniature airplane on the flight indicator drops below the horizon bar or you will fly into the ground. Control airspeed with slight change in attitude.

Immediately after leaving the ground you'll find yourself in sudden darkness. Fly by reference to instruments. Flying half contact and half instruments at night is fatal, especially on takeoffs over dark areas. Pilot should be entirely on instruments but copilot can remain in outside contact when not checking instruments, his principal duty. It is a good idea to ask the copilot to call off airspeeds during night takeoffs. Get an altitude of 500 to 1000 feet before referring to the terrain and don't attempt to turn until you have full climbing airspeed and are at least 1000 feet above the terrain.

**Caution:** Warn the copilot not to glare the flashlight in your eyes if he is using it for periodic check of instruments.

### Alert Your Crew

Spotting other aircraft should be the regular job of your crew just as in combat. Require them to report the position and direction of travel of all aircraft within the zone of vision of their respective positions. Check immediately with the responsible crew member if an airplane appears unreported. Make your crew feel you are relying on them for specific duties.

### Don't Chase Lights

It is difficult to tell whether a light is in the air or on the ground, whether it is moving or standing still. Don't chase lights. You may find

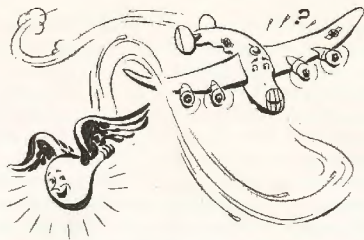

you have unintentionally dropped a wing to follow a light. The best procedure is to closely follow your gyro heading, check the attitude of your airplane and line up the light with a reference point on the airplane. Then you can soon tell whether it is moving, and in what direction in relation to your line of flight.

## Cruising tips

1. Synchronize propellers with a flashlight or by the reflection from landing lights.
2. Require the entire crew to use oxygen from the ground up for all flights above 10,000 feet.
3. Require the copilot to check all instruments regularly—with a filtered flashlight if difficult to read.
4. Restrict banks to standard needle-width turns.
5. Keep track of where you are and require a record to be kept of the time flown on each heading.
6. Keep an hourly log of fuel consumption without fail.
7. Require the radio operator to send in position reports every 30 minutes.
8. Know the terrain over which you are flying, elevations, location of airfields, location of airways, etc.
9. Don't unnecessarily increase the intensity of cockpit lights when flying instruments at night. This impairs night vision for at least 30 minutes after lights are turned down.
10. Turbulence: Reduce airspeed to 150 mph to reduce strains on the aircraft.



11. Remember that a flash of lightning can cause temporary blindness for 10 minutes or more. Where there are repeated flashes of lightning, it may be necessary to turn on all cockpit lights as bright as possible and go entirely on instruments. If static gets bad in the headphones, turn volume low or put earphones up off ears.

#### Radio Failure

In case of complete failure of the radio, attract the attention of the tower by flying over the field 500 feet above traffic and repeatedly flashing the landing lights or signaling with the recognition lights or the Aldis lamp; obtain clearance to enter traffic by light-gun signals from the tower.

#### Night Landings

Always know the altimeter setting, exactly what traffic pattern is used, and the altitude before takeoff. At strange fields notify the tower of your presence early. One of the main jobs of the tower is to tell you the number and location of other aircraft in the area. Remember that day and night traffic altitudes differ at many fields, usually being higher at night. Give the tower a chance to warn you of traffic conditions. It may be necessary to hold you in a zone until other operations are completed. Ask the heading of the landing runway, the wind, altim-

eter setting and the length of the landing runway so you know exactly what to prepare for and to expect. Plan ahead.

As soon as you are called in, proceed at once to join traffic. Tell the tower where you are, and call as you enter the downwind leg, base leg, and final approach. The more information the tower has about you, the more it can do to guide you safely in traffic.

Execute procedures just as in the daytime. Flying your gyro heading and timing your distance out from the end of the runway on the downwind leg is doubly important. Remember that a high wind will drift you out considerably on a long base leg.

#### Turning on Final Approach

One of the key points in night flying is judging when to turn on final approach. Your turn will carry you about  $\frac{3}{4}$  of a mile closer to a projection of the landing runway. As you come along



1  
RUNWAY LIGHTS APPEAR TO BE IN SINGLE ROW AT COMPLETION OF TURN ON TO BASE LEG



2  
START TURN ON FINAL APPROACH AS TWO ROWS OF LIGHTS START TO SEPARATE

the base leg, the 2 rows of runway lights will look like a single row. Start your turn at the moment the 2 rows of lights start to separate. Complete your roll-out from your standard-rate turn just as the rows of runway lights are squared away at full width. Don't lose altitude in your turn. The most common error is not to lead the turn enough, find that you are going

## RESTRICTED

too far past the straight line with the runway, and then to steepen the turn. **Don't make this mistake.** Turns steeper than standard rate should not be made at night in a B-24, especially at reduced speeds used in the traffic pattern.

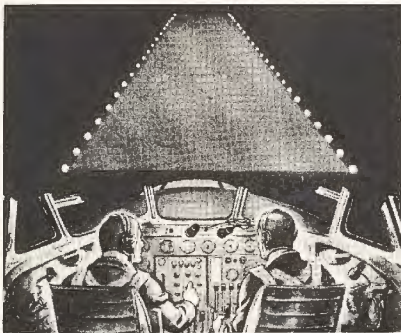

**TOO LOW—LIGHT PATTERN APPEARS FLAT**

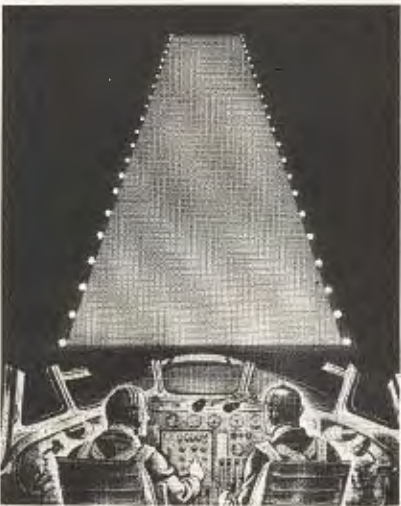

**TOO HIGH—LIGHT PATTERN APPEARS TO RUN UPHILL**

### Final Approach

Make sure of your line-up with the runway just as soon as your turn on final is completed. Then you are free to concentrate all your attention on your descent. Turn your landing lights on as soon as you roll out on final approach. In case a hazed condition blinds you, it is satisfactory to use only the landing light on the copilot's side until you are closer to the field.

Pull up closer to the field at night than in the daytime. You want to make a somewhat steeper approach, controlling your descent carefully with power. When you are high, the double row of runway lights at the far end of the field appear to be raised up. When you are low the pattern of runway lights flattens out. What you want to do is to pick a landing spot and make it good.

### Making Good Your Point

The green lights at the approach end of the runway are the point you want to make good. As you start your descent, line up these lights with a reference point on the outline of the nose or in your windshield. If the green lights move higher, you are undershooting; if they move below your reference line as you descend, you are overshooting. Make adjustments in power accordingly. As in a day landing, maintain a descending airspeed of 125 mph and a descent rate of about 500 feet a minute. Keep your copilot on his job. Have him call off both airspeed and altitude.

### How to Use Your Eyes

Remember the principles of night vision. Don't look at things directly. Keep your eyes shifting from the general pattern of lights, to the point you want to make good, to what your landing lights reveal, etc. Don't stare at the whole pattern of lights or you will think the field is closer than it actually is and you'll want to flare out too high. Don't stare down the landing lights or you'll tend to fly into the ground, leveling off late. Remember that the angle of your landing lights to the ground will change as you change the attitude of the airplane. At the beginning of your descent, they will be at a steeper angle than your descent path. As you come into your

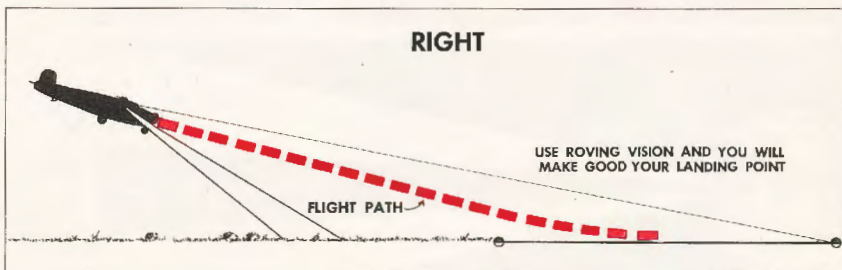
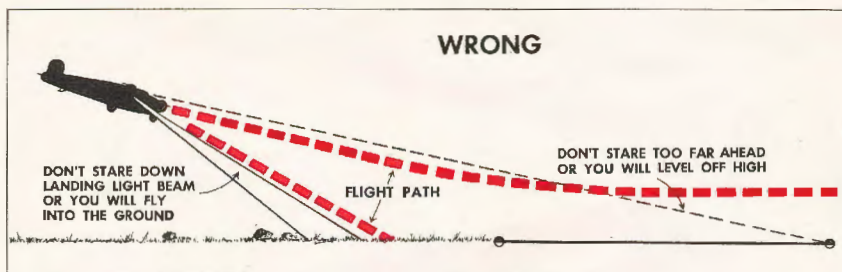

flare-out, they will make a shallower angle than your path of descent.

Watch out for red obstacle lights. These may be 50 to 100 feet above the ground and may be on water towers, or on poles with wires strung between. Don't ever get below them.

#### The Flare-out

If you control your descent to make good your point, it will bring you in to make contact within the first  $\frac{1}{3}$  of the runway. When your lights start to pick up detail on the ground, you'll be about 100 feet up and should start your flare-out. The ground will be well illuminated and objects clearly defined. The usual tendency is to flare out too high and pull power completely off too soon. Coordinate the reduction of power with your flare-out but keep some power on to control your rate of descent and to

let you down easy. Don't pull all power off until you touch. Note tire marks and the size of runway lights to help your depth perception. You may think you are down when you're not. Amount of power will vary from 11" to 15", depending on the weight of your airplane.

#### Landing Roll

As soon as your wheels are on the ground, ease the nosewheel down, and test out your brakes somewhat earlier than in day landings. It is more difficult at night to judge how much runway you have left. Make sure you are going to get the airplane stopped before you run out of runway. Clear the runway at once. Don't try to taxi on your own. Ask the tower where to turn and keep moving. There may be another plane behind you that also must clear the runway quickly.

RESTRICTED

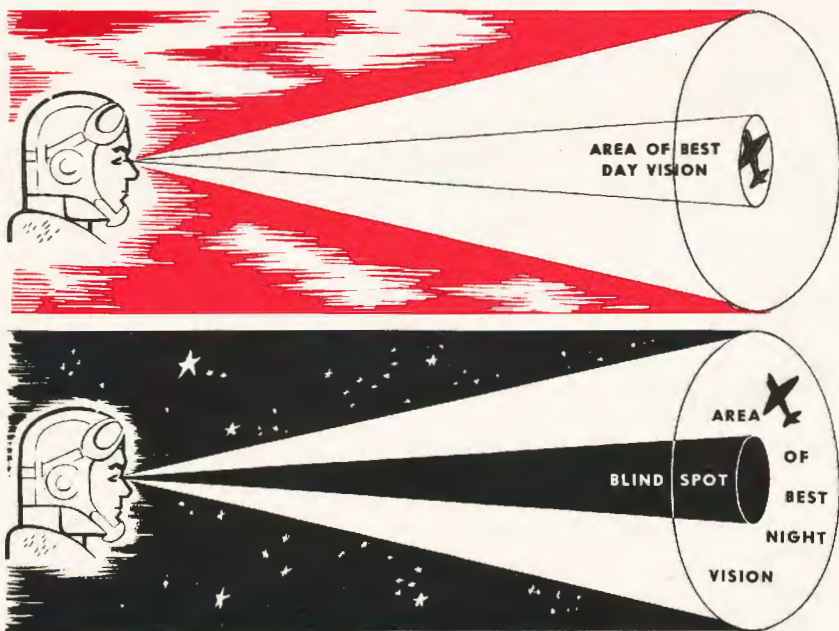

## NIGHT VISION IN THE B-24

A large airplane presents a special problem in night vision. There are a lot of instruments and controls, and there is a temptation to flood the cockpit with white light while you are starting engines and running them up. There are two ways to solve this problem:

1. Use a red filter or cellophane covering over the radio operator's light and over your

night flashlights. Then your eyes will be adapting themselves to darkness during your preparations for flight.

2. Another way is for the pilot to use red adapter goggles until the cockpit lights are out for taxiing, using them again during run-up if necessary. Landing lights will not greatly impair night vision.

## FORMATION FLYING

When you get into combat you will learn that your best assurance of becoming a veteran of World War II is the good, well-planned, and well-executed formation.

Formation flying is the first requisite of successful operation of heavy bombers in combat. Groups that are noted for their proficiency in formation flying are usually the groups with the lowest casualty rates. Proper formation provides controlled and concentrated firepower, maneuverability, cross-cover, and precise bombing pattern, and permits most effective fighter protection.

### Heavy Bomber Formations

Formation flying in 4-engine aircraft presents greater problems than in smaller aircraft. The problems increase in almost direct proportion to the airplane's size and weight. In the B-24, relatively slower response to power and control changes requires a much higher degree of anticipation on the part of the pilot. Therefore you must allow a greater factor of safety.

Violent maneuvers are dangerous and the necessity for them is seldom encountered. Close flying becomes an added hazard; it accomplishes no purpose and is not even an indication of a good formation. Remember that it is much more difficult to maintain position when flying with proper spacing than with wings overlapping.

"Safety first" is a prerequisite of a good heavy bomber formation because of the number of lives and amount of equipment for which the pilot is responsible.

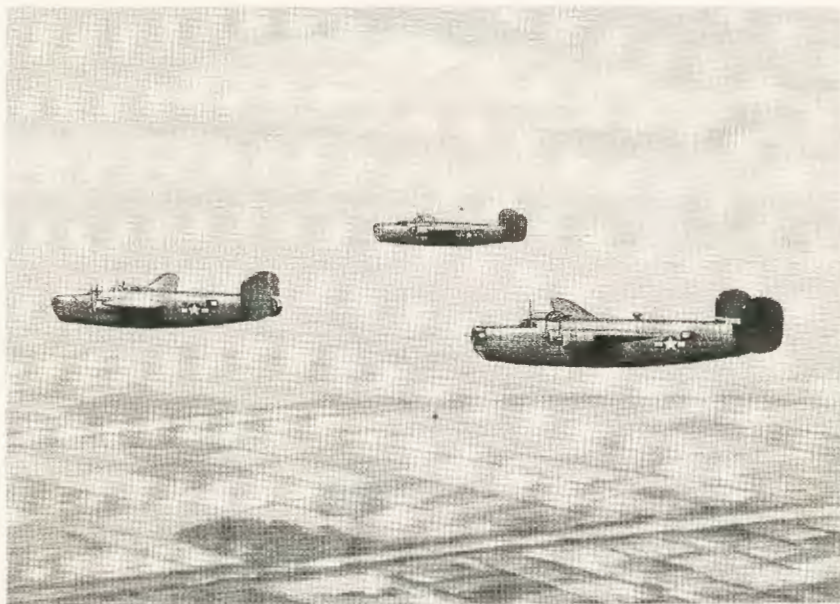



## THE VEE FORMATION

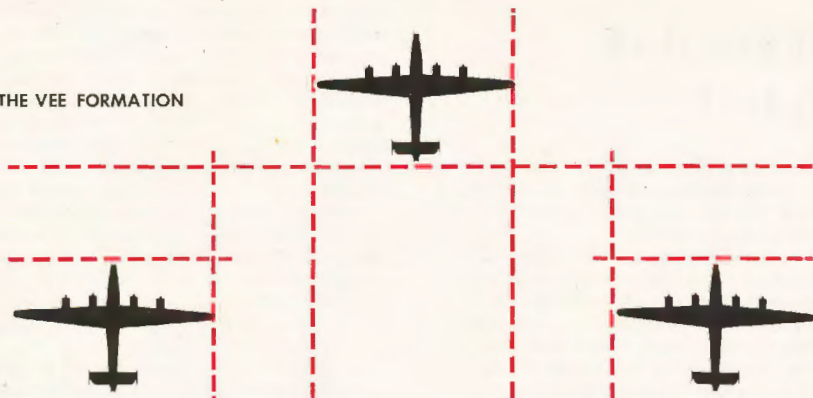

## Clearance in Training Formations

When flying the Vee formation in training, aircraft must not be flown closer to one another than one-half airplane span from nose to tail, and one-half airplane span from wingtip to wingtip. These minimum distances are to be maintained under all formation flying conditions.

Keep yourself posted on current AAF regulations concerning clearances in formation flying, since they may change.

## Taxiing Out

After engines have been started, all planes stand by on proper frequency. The squadron formation leader checks with the planes in his formation, then calls the tower and clears his formation for taxi and takeoff instructions. As he taxis out, No. 2 man follows, then No. 3, etc., each airplane taking the respective place on the ground that is assigned to it in the air. As soon as the leader parks at an angle near the end of the takeoff strip, the other aircraft do the same. At this point all planes run up engines and prepare for takeoff. The leader makes certain that everyone is ready to go before he pulls onto the takeoff strip.

## Takeoff

Squadron formation takeoffs should be cleared from the airdrome in a rapid and efficient manner. Individual takeoffs will be made, and the following procedure is suggested.

The leader goes into takeoff position and takes off at H hour. No. 2 man starts pulling into position as soon as the leader begins to roll. When the leader's wheels leave the runway, No. 2 starts taking off, thus creating a time lapse of about 30 seconds between takeoffs. Similarly, No. 3 follows No. 2, etc. The leader flies straight ahead at 150 mph, 300-500 feet per minute ascent, for one minute plus 30 seconds for each airplane in the formation. He levels off at 1000 feet in order to avoid necessitating high rates of climb for succeeding planes, and cruises at 150 mph.

As soon as the leader has flown out the exact required time, he makes a  $180^\circ$  half-needle-width turn to the left. The second airplane in formation assumes the outside, or No. 2, position, while the third airplane assumes the inside, or No. 3, position. The leader of the second element assumes position on the outside of the formation and the airplanes in his formation assemble on him in the same manner.

## FORMATION TAKEOFFS

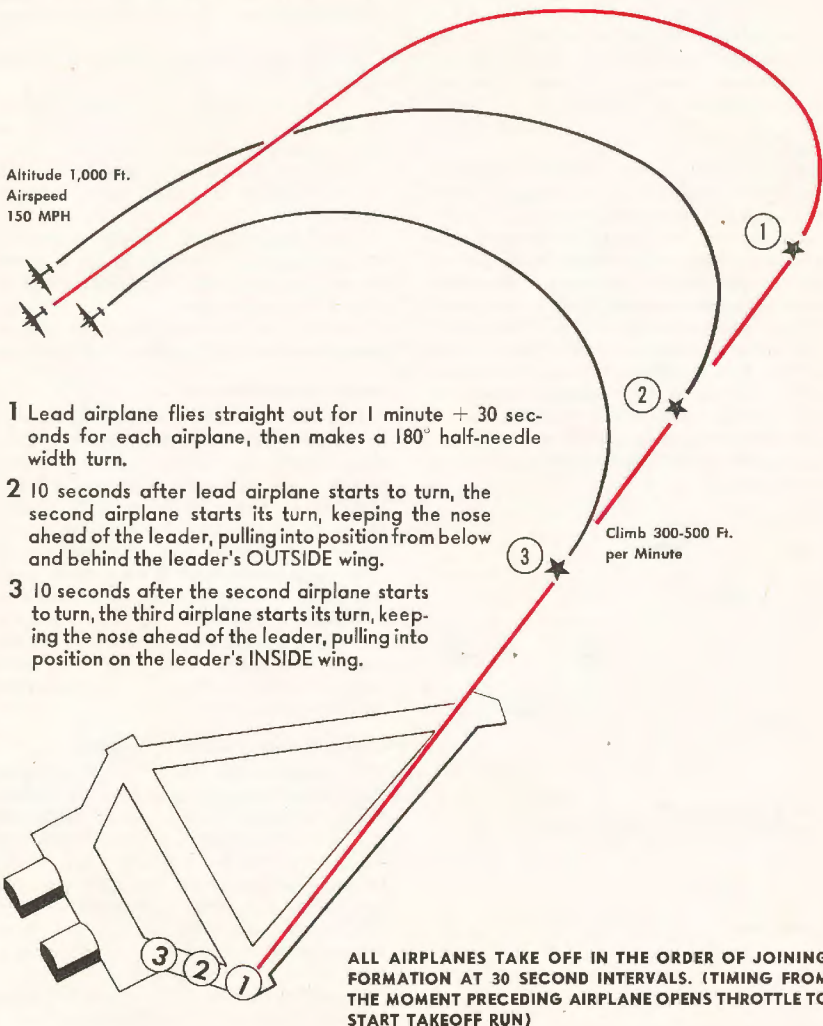

## RESTRICTED

### 3-Airplane Vee

The 3-airplane Vee is the standard formation and the basic one from which other formations are developed. Variations of the Vee offer a concentration of firepower for defense under close control with sufficient maneuverability for all normal missions, and afford a bombing pattern which is most effective.

### Flight of 6

A formation of 6 aircraft is known as a squadron, and is composed of two 3-airplane Vees. At least 50 feet vertical clearance must be maintained between elements in a squadron, with a minimum horizontal clearance of half an airplane's length between the leader of the second element and the wingmen of the first element.

From the basic squadron formation of 6 aircraft the group, made up of 12 to 18 aircraft, is formed. With but small variations, this can be changed to the combat formations used overseas. It is the purpose of training to teach a basic formation which can be readily understood and flown by students and easily adapted to tactical use.



TOP VIEW

## *Element of Six*

FRONT VIEW



### Spacing of Wing Positions

It is particularly important for the leader to avoid violent maneuvers or improper positions which will cause undue difficulty for the wingmen.

The spacing of the wing positions in Vee formation is:

1. Vertically: On the level of the lead airplane.
2. Laterally: Far enough to the side to insure one-half airplane span clearance between the wingtips of the lead airplane and the wing airplane.
3. Longitudinally: Far enough to the rear to insure one-half airplane length clearance between the tail of the lead airplane and the nose of the wing airplane.

Turns in Vee formation should maintain the relative position of all airplanes in the element.

### Practice Trail Formations

A formation is in trail when all airplanes are in the same line and slightly below the airplane ahead. The distance between airplanes will be such that the nose of each airplane is slightly to the rear of the tail of the airplane ahead. It is important that this distance be properly maintained, since if it becomes too great the propeller wash of the airplane ahead will cause difficulty in maintaining formation. Trail formations are to be used only when there are from 3 to 6 aircraft involved, and for purposes of changing the lead, changing wingmen, training in leading elements, and as an optional approach to peel-off for landing.

### Changing Wing Position in Training

When changing from Vee to Trail, the wingman into whom a turn is made while in Vee assumes the No. 2 position in Trail, while the outside man takes No. 3 position. When return from Trail to Vee, the No. 3 man in Trail assumes the inside position of the Vee. Remember this, for it is the procedure for changing from Vee to Trail and from Trail to Vee. Also, as explained below, it provides a method for changing positions in a Vee formation.

It is often desirable for a leader to change the wing positions of his formation, i.e., to

VEE-TRAIL-VEE  
NO CHANGE IN WING POSITION

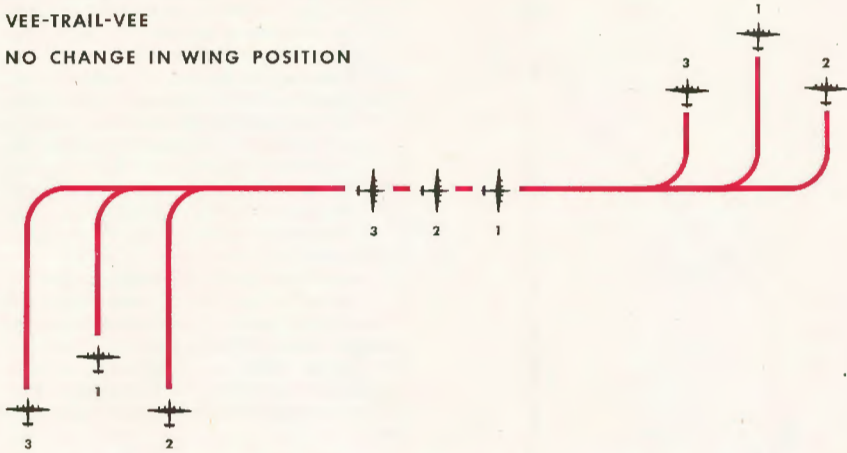

VEE-TRAIL-VEE  
CHANGE WING POSITION



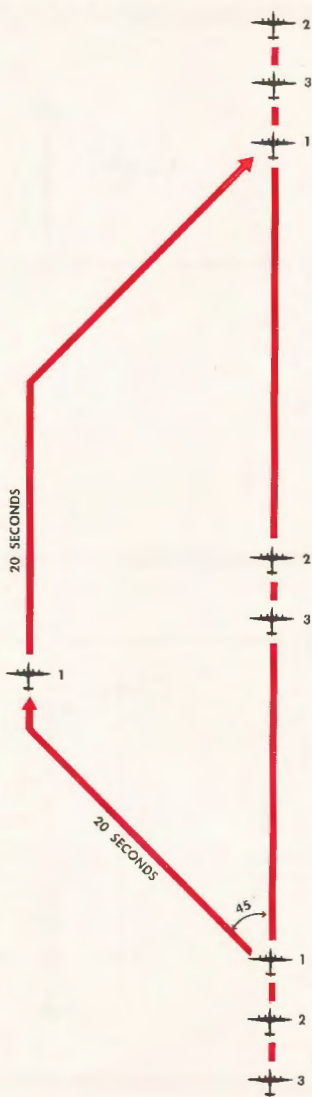

reverse the right and left positions. This maneuver offers danger of collision unless it is executed properly in accordance with a pre-arranged plan. A safe procedure is for the leader to announce on the radio that the formation will go into Trail on his first turn. If the turn is executed to the right, it results in the inside man, or No. 2 wingman, becoming No. 2 in the Trail, and the outside man, or No. 3 wingman, being No. 3 in the Trail when the turn is completed. The leader then announces that the formation will re-form in Vee when the Trail executes a turn to the right. This second turn to the right re-forms the Vee with the wingmen reversed.

As stated previously, this results in the No. 2 man of the Trail assuming the outside position of the Vee, as the No. 3 man takes the inside position. Before making each turn it is desirable for the leader to designate the ultimate position that each wing man is to assume. This will insure complete understanding of the maneuver.

#### Changing Lead in Training

The formation goes into Trail from the usual 90° turn to the right or left. The leader of the formation makes a 45° turn to the left and flies that heading for approximately 20 seconds or until a turn back will place him in the rear of the formation. When the No. 1 airplane starts his 45° turn, the No. 2 plane in the Trail immediately becomes the leader of the formation and continues to fly straight ahead. At the end of 20 seconds or thereabouts, the original leader turns back and takes up the No. 3 position in his element, or the No. 6 position if in a flight of 6, and notifies the new leader that the maneuver is complete.

#### Landing from Vee of Squadron in Training

The formation approaches the airdrome at traffic pattern altitude, into the wind up the landing runway, at which time the wheels are ordered down by the leader and the checklist accomplished. Flaps are lowered 20° and an air speed of 135-140 mph established. The leader signals No. 3, when over the edge of the landing runway, to peel off, No. 3 acknowledging by peeling off. No. 1 follows, No. 2 fol-

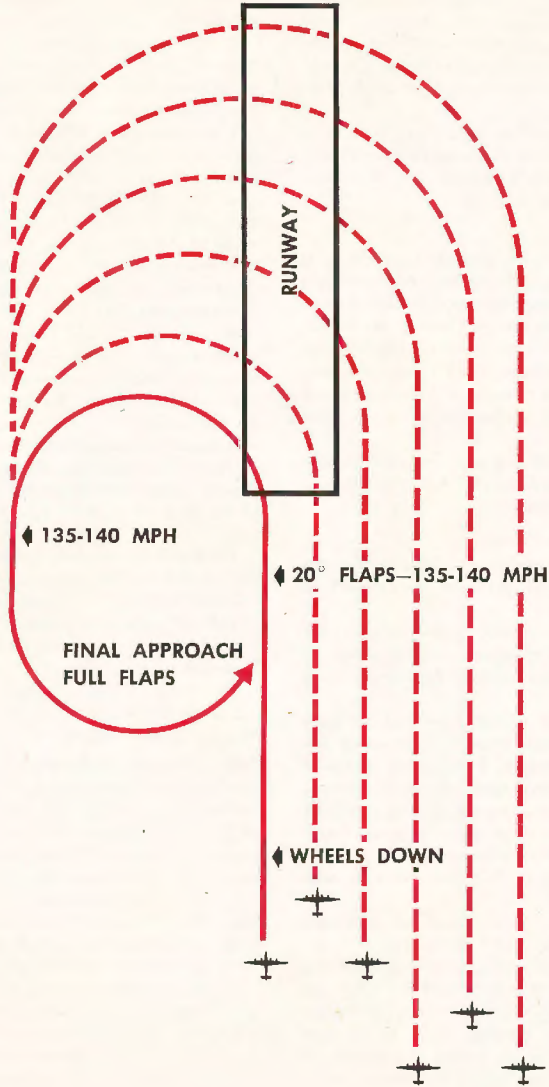

## RESTRICTED

following No. 1, No. 6 following No. 2 and so on. If there is more than one squadron in the formation, the second makes a 360° turn above traffic pattern altitude and approaches the field after the first squadron has completed its peel-off.

Peel-off does not mean a chandelle or a dive. It should consist of a moderate, **level** turn until the airplane is definitely away from the rest of the formation.

### Conclusion

This fact cannot be too strongly stated: a good formation is a safe formation. Air collisions usually result from carelessness or lack of clear understanding between members of the formation. If the simple rules given here are followed explicitly there should be no excuse for mistakes in the air. A mistake in formation flying may mean a costly, irreparable loss of lives and equipment.

Remember that flying too close is not a display of skill; it is a display of bad judgment and lack of common sense.

### Tips on Formation Flying

1. Set rpm to minimum allowable for the maximum manifold pressure you expect to use.

2. At altitudes where superchargers are needed, set superchargers to give about 5" more manifold pressure than the average being used.

3. Use throttles to increase and decrease power in maintaining position. Very small corrections should suffice, if you think ahead of the airplane and anticipate necessary changes, and if you give the correction time to take hold. But when far out of position, or when catching up with a formation, increase rpm to maintain proper manifold pressure and rpm relationships.

4. When under attack, use all available power required to stay in formation.

5. In order to keep formation when operating on three engines it is necessary for pilot and copilot to react as a team in applying the required new power settings while the airplane still has momentum and before it falls behind. If you wait too long before increasing power

you drop back out of formation, and have a difficult time catching up.

6. When changing leads in practice formations or in Trail positions, avoid closing to proper formation position too rapidly. This can be dangerous.

7. In moving about in position, move the airplane in a direction that will not interfere with or endanger any other aircraft in the formation. In route formation, aircraft should be spread in width rather than depth, thereby being able to resume tight formation quickly.

8. Remember that at high altitudes the rate of closure is much more rapid than at low altitudes; you may have difficulty in slowing down quickly enough. Therefore, you have to begin stopping the closure much sooner. On the other hand, acceleration is slower, so that your anticipation of change in position must be more acute.

9. Learn to anticipate changes in position so that only slight control corrections are necessary. Large corrections and constant fighting of the controls quickly wear out even a strong pilot.

10. Keep the airplane properly trimmed to compensate for consumed fuel, crew movement, released bombs, etc. A poorly trimmed airplane is difficult to hold in position.

11. Do not use only the outboard engines to maintain position; use all 4 engines.

12. Always enter a formation from **below**, which is preferable, or from the same level, but **never from above**.

### Power Changes in Formation

The recommended method of varying power in formation is to use the throttles. To do so, reduce turbo boost, fully open the throttles, and then increase turbo boost until you get the maximum power allowable for the rpm you are using. You may then vary the throttles from closed to full open with no harm to the engines.

In loose formation at low altitude, it is possible to use the TBS by adjusting it to position "8" and opening the throttles until you get maximum power allowable for your rpm. Then the TBS range from "0" to "8" may be used safely. This procedure is not recommended, however; use of throttles is preferred.

RESTRICTED

**A COMBINATION OF POWER SETTINGS AND PERCENT OF POWER INCLUDING BMEP VALUES FOR VARIOUS ALTITUDES AND POWER SETTINGS THAT WILL PROVE HELPFUL IN PLANNING YOUR FORMATION FLIGHTS**

RPM	MP ALL ALT.	ARMY MODEL B-24 NAVY MODEL PB4Y-1 RPM vs. MANIFOLD PRESSURE CHART R-1830-43 & R-1830-65 ENGINES			
2550	46.0				
2500	42.5				
2450	40.0				
2400	37.5				
2375	37.0				
2350	36.0				
2325	35.5				
2300	35.5				
2275	35.0				
2250	35.0				
2225	33.5				
2200	32.0				
2175	32.0				
2150	31.5				
2125	31.5				
2100	31.5				
2075	31.0				
2050	31.0				
2025	31.0				
2000	31.0				
1975	31.0	MP S.L. To 25,000	MP 25,000 & Above		
1950	31.0	31.0	30.5		
1925	31.0	31.0	30.5		
1900	31.0	31.0	30.5		
1875	31.0	31.0	30.5		
1850	31.0	31.0	30.5		
1825	31.0	31.0	30.5		
1800	31.0	31.0	30.5		
1775	31.0	31.0	30.5		
1750	31.0	31.0	30.5		
1725	31.0	31.0	30.5		
1700	31.0	31.0	30.5		
1675	30.0	26.5			
1650	30.0	26.5			
1625	29.0	26.5			
1600	28.0	26.5			
1575	27.5	26.0			
1550	27.0	26.0			
1525	26.5	26.0			
1500	26.0	26.0			

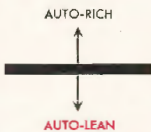

PER CENT POWER	BHP	AUTO RICH	AUTO-LEAN				
		RPM MP BMEP	RPM MP BMEP	RPM MP BMEP	RPM MP BMEP	RPM MP BMEP	
MILITARY AND TAKE-OFF	1200	2700 48.5 192	ALL ALT.	BELOW 10,000	10,000 To 15,000	15,000 To 25,000	25,000 Above
100 (Normal Rated)	1100	2550 46.0 186	(1 HOUR) 260°C HD. TEMP. LIMIT				
90	990	2490 41.5 172	For Continuous Operation at All Other Powers Do Not Exceed 232°C				
80	880	2400 37.5 158	IMPORTANT NOTE:				
75	825	2325 35.5 154	Do Not Increase MP More Than 2° Hg. Above Given Values Without Raising RPM				
70	770	2250 35.0 148	BMEP = $433 \times \frac{\text{BHP}}{\text{RPM}}$				
65	715	2200 32.0 140	2200 32.0 140	2200 32.0 140	2200 32.0 140	2200 32.0 140	
60	660	2050 31.0 139	2050 31.0 139	2050 31.0 139	2050 31.0 139	2050 31.0 139	
55	605	1900 31.0 138	1900 31.0 138	1900 31.0 138	2000 3.00 131	2000 3.00 131	
50	550	1750 31.0 136	1750 31.0 136	1850 30.0 129	2000 28.0 119	2000 28.0 119	
45	495	1650 30.0 130	1650 30.0 130	1850 28.5 122	1900 27.0 116	1900 26.5 113	
40	440	1600 28.0 119	1600 28.0 119	1750 26.5 112	1850 24.5 103		
35	385	1500 26.0 111	1500 26.0 111	1750 26.0 111	24.5 95		

RESTRICTED



# WEIGHT AND BALANCE

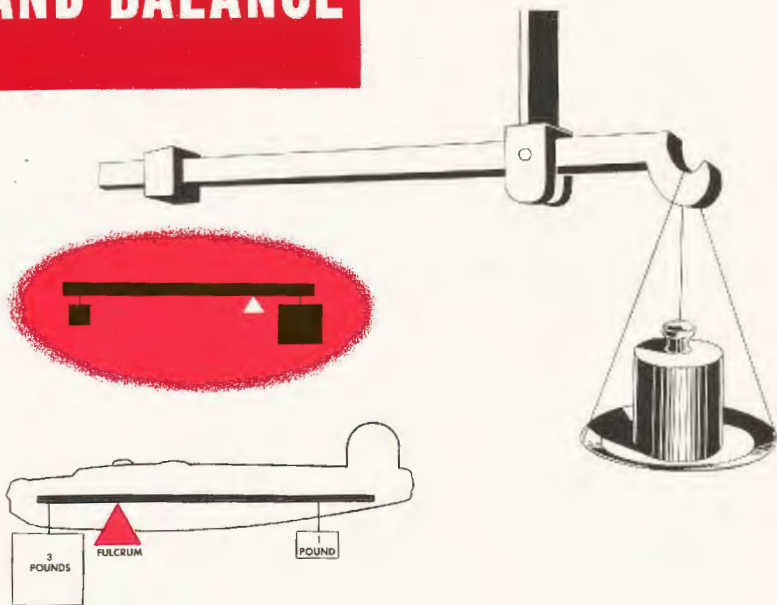

## PRINCIPLES OF BALANCE

The theory of aircraft weight and balance is extremely simple. It is that of the old familiar steelyard scale which is in equilibrium or balance when it rests on the fulcrum in a level position. It is apparent that the influence of weight is directly dependent on its distance

from the fulcrum and that the weight must be distributed so that the turning effect is the same on one side of the fulcrum as on the other. A heavy weight near the fulcrum has the same effect as a lighter weight farther out on the bar. The distance of any object from the fulcrum is called its arm. This distance, or arm, multiplied by the weight of the object, is its turning effect, or moment, exerted about the fulcrum.

Similarly, an airplane is balanced when it remains level if suspended at a certain definite point or ideal center of gravity (CG) location. It is not necessary that an airplane balance so that it is perfectly level, but it must be reasonably close to it. This allowable variation is called the CG range and the exact location, which is always near the forward part of the wing, is specified for each airplane model. Obtaining this balance is simply a matter of placing loads so that the center of gravity falls within the allowable range. Heavy loads near the wing location can be balanced by much lighter loads at the nose or tail of the airplane.

If the CG falls within the CG limits, forward and aft, the loading is satisfactory. If not, the load must be shifted until the CG does fall within the limits.

For flight, since the wing supports the airplane's weight, it is obvious that the CG must remain within safe allowable limits; otherwise, the tail surfaces could not properly control the path of flight. Limits are usually expressed as a percentage of the mean aerodynamic chord of the wing (% MAC). The MAC is simply the width of a theoretical rectangular wing which has the same aerodynamic characteristics as the regular wing.

To obtain the gross weight and the CG location of the loaded airplane, it is necessary first to know the basic weight and the CG location of the airplane. This weighing should be with the airplane in its basic condition; that is, with fixed normal equipment which is actually present in the airplane, less fuel.

When the weight, arm, and moment of the basic airplane are known, it is not a difficult matter to compute the effect of fuel, crew, cargo, armament, and expendable weight as they are added. This is done by adding all the moments of these additional items to the total moment found by weighing the airplane and dividing by the sum of the basic weight and the weight of these additional items. This gives the CG for the newly loaded airplane. This calculation can be performed by arithmetic, by loading graphs, or by a balance computer.

## EFFECTS OF IMPROPER LOADING

### Overloading

1. Causes a higher stalling speed.
2. Always results in lowering of airplane structural safety factors which may be critical during rough air or takeoffs from poor fields.
3. Reduces maneuverability.
4. Increases takeoff run.

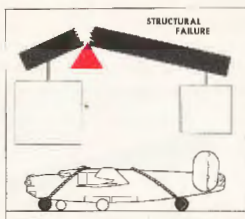

5. Lowers angle and rate of climb.
6. Decreases ceiling.
7. Increases fuel consumption for given speed (decrease in miles per gallon).
8. Decreases range.
9. Lowers tire factors.

### CG Too Far Forward

1. Increases fuel consumption (less range); decreases maneuverability.
2. Increases power for given speed.
3. Oscillating tendency—increased strain on pilot during instrument flying.
4. Tends to increase dive beyond control.
5. Might cause critical condition during flap operation.

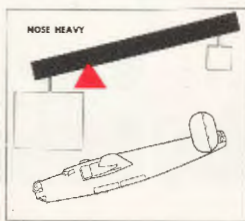

## RESTRICTED

6. Increases difficulty in getting nose up during landing.
7. Overstresses nose wheel.
8. Results in dangerous condition if tail structure is damaged or surface is shot away.

### CG Too Far Aft

1. Creates unstable condition.
2. Increases stall tendency.
3. Definitely limits low power; might affect long-range optimum speed adversely.
4. Decreases speed.
5. Decreases range.
6. Increases pilot strain in instrument flying.
7. Results in a dangerous condition if tail structure is damaged or surface is shot away.

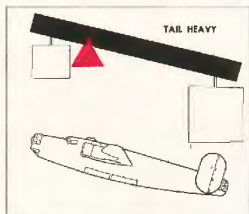

8. A sudden upgust or downgust may cause stall before recovery is possible. The reason is that the elevator is trimmed to keep the nose down. Each bump throws the nose up. In case of a severe bump there is little elevator travel left to bring the nose down, making a recovery difficult.

## PROPER LOADING OF THE B-24

The day is past when the pilot makes decisions by the seat of his pants, and the loading of aircraft is no exception. Especially is this true in the B-24. Here is a high performance airplane if properly loaded. But you can't expect normal performance if you hang a ball and chain on the tail, put a ring in the nose with hundreds of pounds hanging from it, or suspend an anchor from one wing. Improper loading at best cuts down the efficiency of the airplane and at worst can cause a crash.

In transition, pilots learning to fly the B-24 sometimes get in the habit of overlooking weight and balance because there are often only a few individuals aboard, no bombs, no ammunition and the distribution of weight is of less importance. Bear in mind that the tactical Air Force you join will expect you to **know** weight and balance when you arrive. Any B-24 airplane commander worth his salt will take time to master the relatively simple operation of the load adjuster.

**Note:** There is a load adjuster for every airplane. On the back of its case are blank spaces for 4 items: 1. AF No.....; 2. Model.....; 3. Basic Wt.....; 4. Index..... Fields will refuse to clear you for departure unless these items are filled out and unless you can complete a Form F (weight and balance clearance) for the flight as required by AAF regulations.

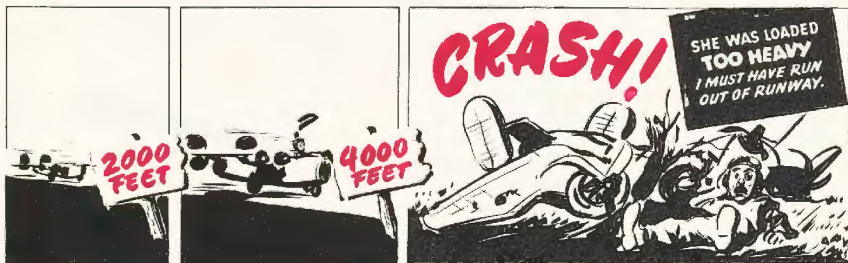

## INSTRUCTIONS FOR OPERATION OF THE B-24 LOAD ADJUSTER

The load adjuster is the calculator used in conjunction with the **Weight and Balance Handbook**. Proficiency in its operation will save the time and effort of tracking down the elusive CG by means of mathematical calculations. Its use in conjunction with the charts and forms contained in the handbook insures a safe loading and provides a means of checking exactly how the balance position will be affected by each item of load which is added or expended.

The colored top strip is the guide to a safe loading. The actual loading range is the area between the yellow sections. The yellow area restricts these limits further for certain conditions. These conditions vary with each airplane. On B-24D, E, G, H, and J load adjusters a restriction is imposed when fuel is carried in the forward bomb bay. This caution is noted so that the allowable rear limit will not be exceeded as the balance position moves aft with the consumption of this fuel. When there is no forward bomb bay fuel aboard, this yellow section may be disregarded.

The sloping lines indicate the limits of the loading range for the gross weights to which the airplane is to be loaded. Examination of the top strip will show that at high gross weights the forward section of the loading range increases but diminishes at the rear limit. Comparison of the top strip with the center of gravity grid will explain the reason for these sloping limits.

The movement of the hairline indicator translates the change in balance position as load is added or expended in terms of the index scale which appears on the bottom of the rule. This index is merely a simple reference that is mathematically related to the center of gravity grid which appears on the inside of the load adjuster.

The center of gravity grid on the inside

of the rule is the basis of the load adjuster's design. The forward and aft red sections show the CG limits in terms of % MAC, and it is from these limits that the top strip of the load adjuster is derived. The dotted lines show the fuel travel and determine the yellow caution areas for this airplane.

The CG position in terms of % MAC and inches from the reference datum may be read directly from this grid. The crosswise lines represent the weight and the diagonal, downward lines represent the percent. To convert an index reading to % MAC, note the point at which the indicator hairline and the gross weight line intersect and the % MAC is estimated at that intersection. The marks across the top of the grid are in inches from the reference datum. The position in inches is read in the same manner as the % MAC since, had the lines for inches been extended downward, they would follow the trend of the percent lines.

The fuselage diagram on the back of the load adjuster will be of great assistance in deciding where to place load items. It also provides information concerning leveling lugs, jig points, etc., to assist you in the actual weighing of the airplane. The loading scales on the front of the load adjuster are lettered to correspond with the compartment letters on the diagram on the back of the load adjuster.

The basic weight and moment scales on the inner side of the load adjuster slide determine for you in a few simple operations the basic index which is the starting point of all loading calculations. All that you need do to arrive at a basic index is set the indicator hairline at "0" on the index scale. Then, move the slide until the basic weight is under the hairline. Follow that up with a quick slide of the indicator to the basic moment/1000 and the basic index is right there under the hairline staring you in the face. If the basic moment/1000 should happen to be on a scale other than that containing the basic weight, don't be alarmed. Just set your basic weight as above; move the indicator to the final moment/1000 mark at the end of the scale containing the basic weight; then move the slide again until the same moment/1000 mark at the beginning of the next scale is

**RESTRICTED**

under the hairline. Move the indicator to the moment/1000 figure you were looking for in the first place and the problem is solved.

**Operation of the Load Adjuster**

All loading calculations start with the hairline of the hairline indicator over the basic index.

From there on it requires only 2 operations to lead each of the totals shown on Form F.

The first step is to slide the slide until the "0" vertical starting line of the scale involved is under the hairline.

The next step is to move the hairline indicator until the hairline is over the weight that is to be added. The new index is then read under the hairline on the index scale at the bottom of the rule.

That's all there is to it. These two operations are repeated for each loading total that appears

on Form F. The computations are made in the order that the items appear in the form and the resulting index reading is entered in the index column.

When you're sliding the slide, make sure that you don't move the hairline indicator, and when you move the hairline indicator, see that the slide remains in position.

Following these two steps, work out a simple problem. Don't base any of your field problems on the data given. This is just to help you to operate your load adjuster.

Suppose the card in the load adjuster case in agreement with chart C in the handbook in your airplane shows a basic weight of 36,767 lb. and a basic index of 63.8.

The index readings for each of the compartments are shown so that you can start working

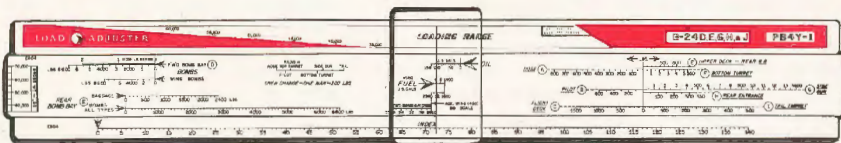

**LOAD ADJUSTER SHOWING LOADING SCALE**

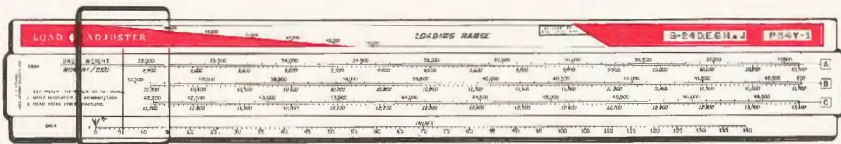

**LOAD ADJUSTER SHOWING BASIC WEIGHT AND MOMENT SCALE**



**LOAD ADJUSTER SHOWING FUSELAGE DIAGRAM**

## RESTRICTED

your load adjuster, and check your answers with the index readings given.

Now, get a B-24 load adjuster and get your copilot and your engineer. If you can't get hold of a load adjuster any other way, get permission to go sit in an airplane. Then work out the following problem using the basic index given in the problem. You'll use the actual basic index for the airplane after you have learned to use the load adjuster. Have a Form F and fill it out as you go along. As soon as you have mastered this problem, teach it to your copilot and then to your engineer. Whenever a weight and balance clearance is necessary, you, the airplane commander, must either figure it and have it checked by copilot or engineer or have one of them figure it and you check it.

Set the indicator hairline over the basic index of 63.8 and begin.

1. Slide the slide until the "0" vertical starting line of the compartment scales is under the hairline.

2. Move the indicator until the hairline is over 260 lb. on Nose Scale A. This adds the moment of the 260 lb. in that compartment and produces a new index reading of 57.4.

3. With the hairline over the new index of 57.4 slide the slide until the "0" starting line of the compartment loads scale is again under the hairline.

4. Move the indicator to the 400-lb. mark on scale B and read the new index of 51.2.

Following the above steps, work out the other compartment loadings by yourself. You should not need any further illustration. Each new addition is made with the indicator hairline over the index determined from the previous operation.

### Minimum Landing Check

Having added all the items of non-expendable load you have now arrived at the minimum landing check. The hairline of the indicator is well within the white section and the CG is, therefore, within the loading limits.

Unless there is a most unusual loading condition, when the balance position at "Minimum Landing Gross Weight" and at takeoff is within the loading limits, no adjustments will be neces-

## RESTRICTED

sary during flight to keep plane in balance.

If the indicator hairline is, at this point, in either the forward or aft red section, readjust your cargo or provide necessary ballast (gross weight limits permitting), so that the minimum landing check will show a balance position within the loading range.

### Loading Expendable Items

In order to complete calculations, now add the so-called expendable load. In this problem ammunition, bombs, oil, and fuel have to be considered. They are added in the same manner as the compartment totals but separate scales are provided for the bombs, oil and fuel. The compartment scales are used for the ammunition.



1. With the indicator hairline over the minimum landing index of 65.8, slide the slide until the "0" starting line of compartment scales is under the hairline.

2. Move the indicator until the hairline is over the 240-lb. mark on nose scale A. This adds the 800 rounds of .50-cal. ammunition in compartment A. The new index reading is 59.9.

3. Repeat these operations for each of the compartment ammunition loadings using the scales in the same manner as they were used for the addition of the non-expendable items in the compartment sections.

## RESTRICTED

4. For the addition of the bombs a separate set of scales is provided. Therefore, with the indicator hairline over the last index determined from the ammunition loadings, 79.1, slide the slide until the "0" starting line of the forward bomb bay scale is under the hairline.

5. Move the indicator until the hairline is over the 6400-lb. mark on the forward bomb scale, thus adding the four 1600-lb. bombs in the forward bomb bay and providing a new index reading of 61.1.

6. Using the rear bomb bay scales, repeat the same operation for the bombs in the rear bay for a new index of 83.2.

7. Slide the slide until the vertical starting line of the oil scale is under the hairline.

8. Move the hairline indicator until the hairline is over the 130-gallon mark and read the new index of 78.1.

9. The indicator hairline is now over the "0" starting line of the wing fuel scale and it will require only one movement of the hairline indicator to add the 2360 gallons of fuel. You could move the indicator to the 1400-gallon mark and then back again to the 2360 but you might just as well move it from the "0" mark

right to the 2360 and let it go at that for a final index reading of 77.0.

### Crew Change Scale

Since the Form F was filled out considering the crew members at battle stations, you had best put the tail gunner and the side gunner in the spots where they will be for landing and takeoff, just to make sure that the balance position will be satisfactory. You will find that the crew change scale takes care of this problem very easily.

1. Set the slide so that the mark for the tail gunner on the crew change scale is under the hairline.

2. Move the hairline indicator so that the hairline is over the bottom turret position since that is where he will be at takeoff.

3. Slide the slide again until the mark for the side gun on the crew change scale is under the hairline.

4. Move the hairline indicator until the hairline is over the bottom turret mark.

5. Now slide the slide until the mark for the nose on the crew change scale is under the hairline.

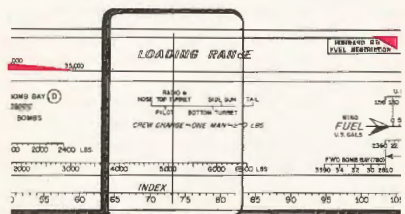
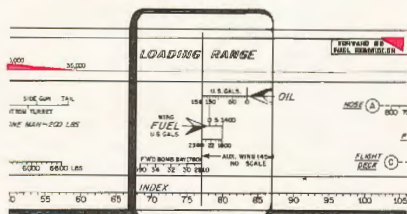
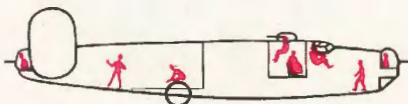

6. Move the hairline indicator until the hairline is over the radio and top turret mark.

These operations have produced an index of 73.2 and placed your crew in the takeoff position. This is your final takeoff index.

You will find the indicator hairline right in the middle of the loading range, so you are now assured that your balance position is perfectly safe.

#### Use of Expendable Items

Since both the minimum landing check and the takeoff index have been within the limits, you can be reasonably certain that all will be well during flight. However, it might be well to see what will happen to your balance position after you have dropped that bomb load, burned the fuel or maybe caught a Jerry or two with the ammunition you had aboard. By checking your balance without these expendable items you can be equally sure of a safe CG when you come in for a landing.

You can check this CG change as load decreases either by adding to the minimum landing index or subtracting from the takeoff index. To accomplish the former, set the indicator hairline over the minimum landing index and use the load adjuster scales to add whatever part of the expendable load is still aboard at landing, always adding full oil first since it is almost impossible to estimate the oil consumption. Then add whatever you have left in the way of expendable items. If the meters show that you still have 200 rounds of nose ammunition, load 200 rounds of ammunition on scale A. If the fuel gauge registers 500 gallons of wing fuel, use the wing fuel scale and add that. Always be sure to check your landing CG. Balance alters with the use of expendable load, so don't rely on your takeoff index to make you land safely.

This computation may also be made by using the load adjuster scales in reverse. This method starts with the indicator hairline over the takeoff index. Set the slide so that the original amount loaded on any one scale is under the hairline and then move the indicator to what you have left.

You may like the first method better because it doesn't require so much mental arithmetic.

However, you ought to know about this "taking out" process because it comes in handy when you find in the course of a loading calculation that re-adjustment of load is going to be necessary. By setting the indicator hairline over the index reading at which the adjustment should be made and by moving the slide to the amount originally loaded on the applicable compartment scale, you can take out whatever you like and then re-load it in some other section where it will improve your balance position. This often saves re-working an entire calculation since the index readings on Form F can be corrected accordingly if not too much re-adjustment of load is involved.



#### Reading CG Position From Grid

To check on reading % MAC and inches from the center of gravity grid, convert your loaded index. Set the hairline of the indicator at the takeoff index of 73.2 and slide the slide so that the gross weight figures on its left-hand end will be conveniently close to the indicator hairline. The intersection of the hairline and the line representing the 65,000 lb., which is the closest to the takeoff gross weight of 64,437 lb., occurs about 1/5 of the way between the 31 and 32% MAC lines. Therefore, the % MAC may be estimated at approximately 31.2% or, expressed in inches, between 299 and 300 inch marks as approximately 299.1.



## FLIGHT CONTROL CHARTS

The average pilot doesn't realize how many horses he is controlling with his throttle hand. Twelve hundred horsepower per engine is a lot. Multiply this by 4 and it's a hell of a lot.

Normally you'll cruise auto-lean at, say 2000 rpm and 30" (181 gallons per hour) or 2050 rpm and 31" (205 gallons per hour), thus using 55 to 60% power—i.e., you are using about 60% of 4800 Hp, or 2880 Hp.

These 2880 horses don't have such a big appetite for fuel—200 gallons an hour is reasonable. But now you decide to use 2250 rpm and 35" which requires auto-rich mixture settings. This is 70% power or 70% of 4800—or 3360 Hp. You've thereby added the difference between 2880 and 3360, or 480 horses, and are they hungry! Your fuel consumption jumps from 205 gallons per hour to 348 gallons per hour. For an increase from 60 to 70% power, you have to use almost 70% more fuel per hour and your gain in airspeed is only 10 mph.

In short, the moment you go into the higher power ranges (where you must use auto-rich), your engines develop a tremendous appetite. That's why pilots have run out of fuel when they *thought* they had several hundred gallons left. Know your power settings.

Remember there is a minimum efficient flying speed. The B-24 has to be up on the step to fly efficiently. This varies with weight. The moment you drop your bombs, this airspeed changes and must be recalculated. You don't conserve gas by mushing along at too low a power setting and airspeed.

The only way to ascertain the proper power settings and airspeeds for various flight conditions is to use the flight control charts or tables.

### Don't Feather to Go Farther in the B-24

It works on some airplanes with light wing loadings, but it won't work on the B-24. To go the same distance, you'll use more fuel with

2 engines feathered than if you use all 4 engines properly.

For example: With a 45,000-lb. weight, cruising at density altitude of 15,000 feet, best power setting is 1700 rpm, 28.3" of manifold pressure. You are getting approximately 490 brake Hp per engine or a total of 1960 Hp to maintain efficient airspeed with minimum fuel consumption of 150 gallons per hour.

Now suppose you feathered 2 engines. The remaining 2 engines still have to produce at least 1960 Hp for them to deliver enough thrust to give you your minimum efficient true airspeed of 153 mph. There's no way to get around that. To do this each of the engines must produce 980 Hp. This will require approximately 90% power or 2490 rpm and 41.5" (in auto-rich). At this setting you will use 254 gallons per hour compared with 150 gallons per hour using all 4 engines. No allowance was made here for loss of efficiency because of the drag of feathered propellers.

Remember there is a big difference between maximum economy and maximum range. If you want to stay in the air as long as possible, you want maximum economy—as in a case where you want to hang around near the field until a ground fog clears.

But maximum economy flying usually means the airplane is in a semi-mushing attitude. It will stay in the air but it won't go any place and it won't get you the most miles per gallon for fuel available. The airplane **must** be flying efficiently to get the most miles per gallon.

---

The charts on the following pages are for instructional use only. For planning actual flights, you will find simplified tables in your G file for the plane you are flying. Such tables are replacing the graph charts, from which they are derived.

Use of the graph charts in your spare time will give you a fuller understanding of the use of the simplified tables. The charts presented serve only as examples of the full series.

---

**EFFECTS OF POWER SETTINGS ON GAS CONSUMPTION AND AIRSPEED**

(Based on 50,000 pound weight cruising at density altitude of 5,000 feet, no wind; see Cruise Control Chart)

POWER SETTING rpm	Manifold Pressure	Brake Horse Power	Gals. Per Hour	Hours and Minutes of Fuel		Indicated Airspeed	True Airspeed	Range in Miles*	What the Table Shows
				H	M				
<b>Auto-Lean</b>									
1500	26"	35%	126	15	52	132	142	2254	Airplane won't cruise at 35% power
1600	28"	40%	134	14	55	152	163	2234	Low fuel consumption. But maximum range would be approx. 42.5% power.
1650	30"	45%	146	13	42	165	178	2438	12 GPH more fuel = gain 15 mph TAS.
1750	31"	50%	161	12	25	173	186	2311	15 GPH more fuel = gain 8 mph TAS.
1900	31"	55%	180	11	07	183	196	2178	19 GPH more fuel = gain 10 mph TAS. Increase in gas consumption of 46 GPH gives increase of 33 MPH TAS.
2050	31"	60%	205	9	45	190	205	2000	25 GPH more fuel = gain 9 mph TAS.
2200	32"	65%	250	8	00	197	212	1696	45 GPH more fuel = gain 7 mph TAS.
<b>Auto-Rich</b>									
2200	32"	65%	306	6	32	197	212	1386	56 GPH more fuel = gain NO mph TAS.
2250	35"	70%	348	5	45	203	218	1252	42 GPH more fuel = gain 6 mph TAS.
2325	35.5"	75%	390	5	08	208	224	1149	42 GPH more fuel = gain 6 mph TAS. Increase in gas consumption of 140 GPH gives increase of 12 mph TAS.
2400	37.5"	80%	428	4	40	213	230	1075	38 GPH more fuel = gain 6 mph TAS.
2490	41.5"	90%	508	3	56	222	238	937	80 GPH more fuel = gain 8 mph TAS.
2550	46"	95%	581	3	27	228	246	847	73 GPH more fuel = gain 8 mph TAS.

These are roughly interpolated figures to give you an idea of the effect of power settings. Note what a change in rpm alone will do. Note what happens when you go into auto-rich—Zoom goes the gas consumption! But remember these figures are for only one weight of airplane at one altitude. Different figures apply for different weights at different altitudes.

\*Based on 2000 gallons of fuel, cruising in level flight.

## HIGH PERFORMANCE TAKEOFF CHART

Normally it will not be necessary to compute takeoff distances when operating from airfields constructed for 4-engine aircraft. However, for heavy loads and for takeoffs from strange and shorter fields it is imperative that you check the length of run required.

In effect a field is a different length every day. Wind will make a field longer, hot weather will make it shorter, air density changes its effective length. The weight of your airplane can shorten or lengthen the field. It will measure the same distance in feet but so far as the B-24 is concerned these elastic takeoff strips stretch and contract with the weather. This means that just because Joe Doakes took off from some field last Tuesday is no reason that you can do it this Saturday. The difference between a warm afternoon and a cold morning can mean as much as 500 feet difference in takeoff run. Variation in wind alone can easily make as much as 1000 feet difference in the length of your ground run. The field elevation and runway surface must also be considered. Before a doubtful takeoff always consult the high performance takeoff chart.

To get the pressure altitude you can ask the weather office or you can set the barometric pressure scale on the altimeter to 29.92 (standard sea level pressure). This will give a reading of the pressure altitude of the airplane above sea level. If this pressure altitude reading is higher than field elevation, the air is less dense than the standard for the elevation (requiring a longer takeoff run than usual), if the pressure altitude reading is lower than field elevation, the air is more dense than standard and takeoff distance should be less than normal.

**EXAMPLE:** (Illustrated on chart with red line)

**Given:** Temperature — 25°C.  
 Gross Weight — 56,000 lb.  
 Field Condition — soft turf.  
 Headwind — 10 mph.  
 Pressure Altitude — 2000 feet.

**Solution:**

Density Altitude — 3550 feet.  
 Ground run—concrete runway—no wind — 2980 feet.  
 Ground run corrected for ground condition (soft turf) — 4200 feet.  
 Ground run corrected for ground condition plus a 10 mph headwind — 3550 feet.  
 Distance for transition and climb to 50 feet (no wind) — 1180 feet (same density altitude used as determined from the ground-run chart).  
 Distance for transition and climb to 50 feet corrected for 10 mph headwind — 1050 feet.  
 Total distance to clear a 50-foot obstacle — 3550 + 1050 = 4600 feet.

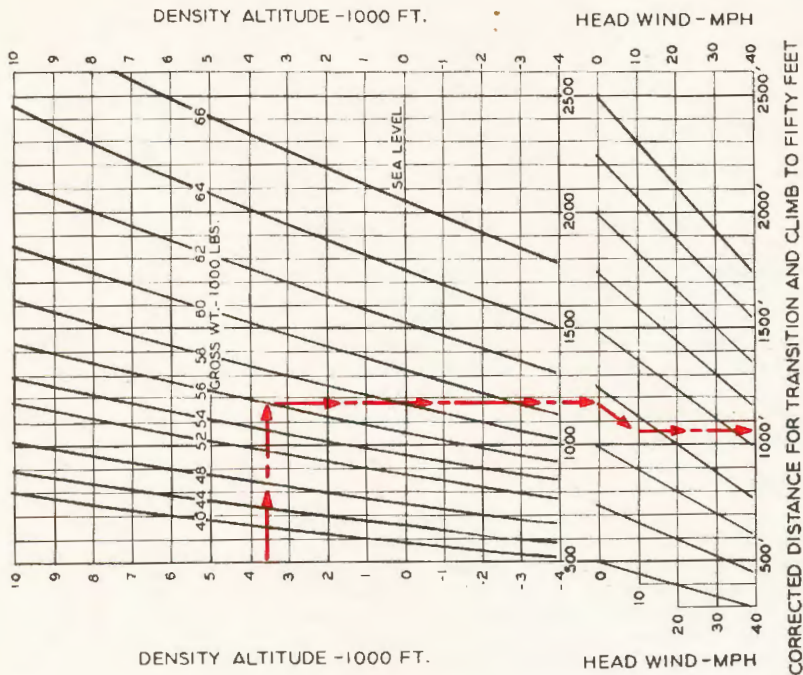

← HORIZONTAL DISTANCE FOR TRANSITION AND CLIMB TO FIFTY FEET ONLY

← GROUND RUN ONLY

**NOTE: THIS CHART IS BASED ON THE FOLLOWING:**

**WING FLAPS —20°, COWL FLAPS —5°, TAKE-OFF POWER—4800 BHP**

**NOTE:** THE TAKE-OFF DISTANCES SHOWN ON THIS CHART ARE **HIGH PERFORMANCE** AND CAN ONLY BE ATTAINED BY FOLLOWING THE PROCEDURE GIVEN BELOW. FOR NORMAL TAKE-OFF CONDITIONS WHERE HIGH PERFORMANCE IS NOT REQUIRED (AIRLINE PROCEDURE) ADD APPROX. 200 FT. TO THE GROUND RUN AND 600 FT. TO THE TOTAL DISTANCE TO CLEAR A 50 FT. OBSTACLE AND INCREASE THE TAKE-OFF VELOCITIES 10 MPH.

**TAKE-OFF PROCEDURE**

1. AFTER WARM-UP, RUN UP EACH ENGINE SEPARATELY TO 2700 RPM AND 47" Hg MP (THIS SETTING ALLOWS FOR A 1½" Hg INCREASE IN MP DUE TO RAM) TO OBTAIN TURBO REGULATOR SETTING.

2. PRIOR TO TAKE-OFF, MAINTAIN TURBO REGULATOR SETTINGS DETERMINED IN ITEM 1 AND REGULATE THE POWER BY MEANS OF THROTTLE ONLY.

3. SET WING FLAPS TO 20° AND COWL FLAPS TO 5°.

4. ON TAKE-OFF DO NOT RELEASE BRAKES UNTIL MP HAS REACHED 35" Hg.

5. UPON RELEASING BRAKES, INCREASE THROTTLE SETTING TO FULL OPEN POSITION AS RAPIDLY AS POSSIBLE.

6. TAKE OFF AT THE INDICATED VELOCITY SPECIFIED ON THE CHART FOR GROUND RUN DISTANCES.

RESTRICTED

# TAKE-OFF CHART (B-24D)

RESTRICTED

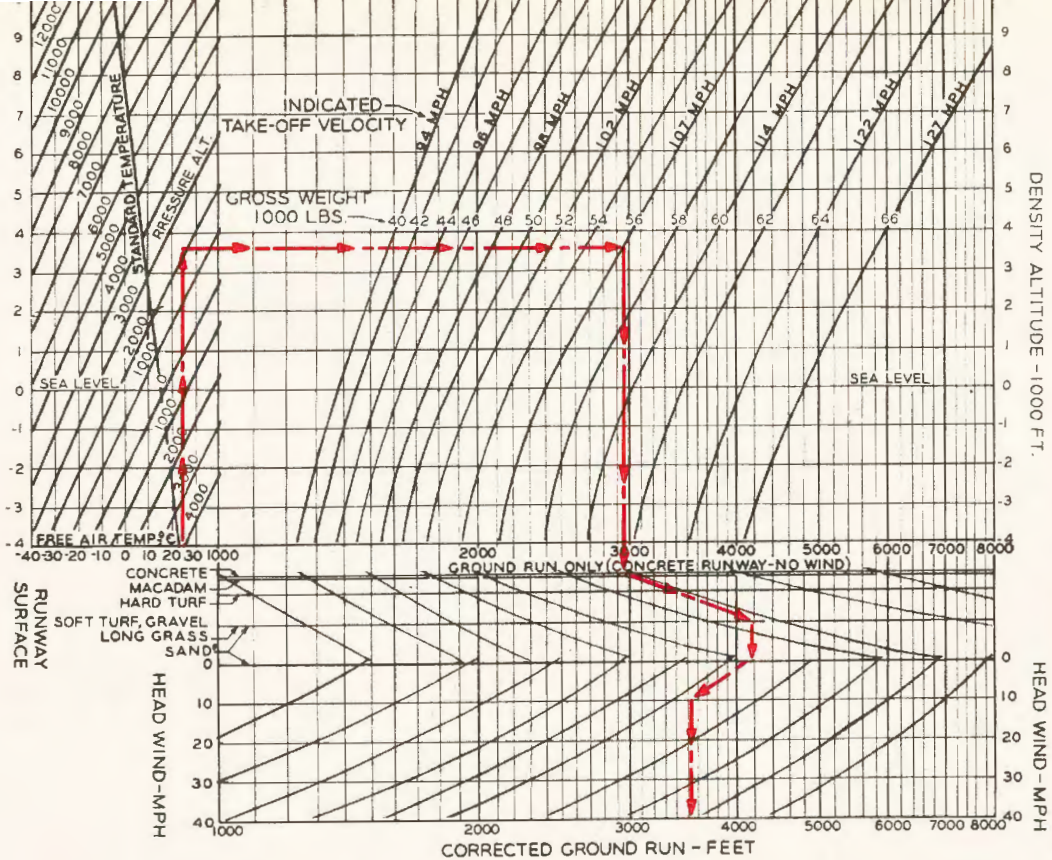

### MAXIMUM RANGE CLIMB CONTROL CHARTS

The maximum range climb control charts are calculated on the basis of rated power climb with a 10° cowl flap opening. A minimum amount of fuel and time is used in attaining a given altitude if normal rated power is used for the climb. These charts enable the pilot to determine the amount of fuel used and the distance traveled (with no wind) while climbing to the altitude, as well as the amount of reduction in range (because of the climb) for any given mission.

**Example:**

At a gross weight of 60,000 lb., the curves show that a climb to 20,000 feet for a B-24D equipped with wide-bladed propellers, requires about 258 gallons of fuel and the distance traveled while climbing (with no wind) is 82 miles. The true IAS (which must be corrected for pitot position error and instrument error) for best climb as given by the curve is 158 mph. Climbing at some speed faster than the value specified will decrease the rate of climb and increase the total fuel consumed and the distance traveled during climb. Climbing at powers lower than rated power will have the same effects as increased speed.

WIDE BLADE PROPELLERS

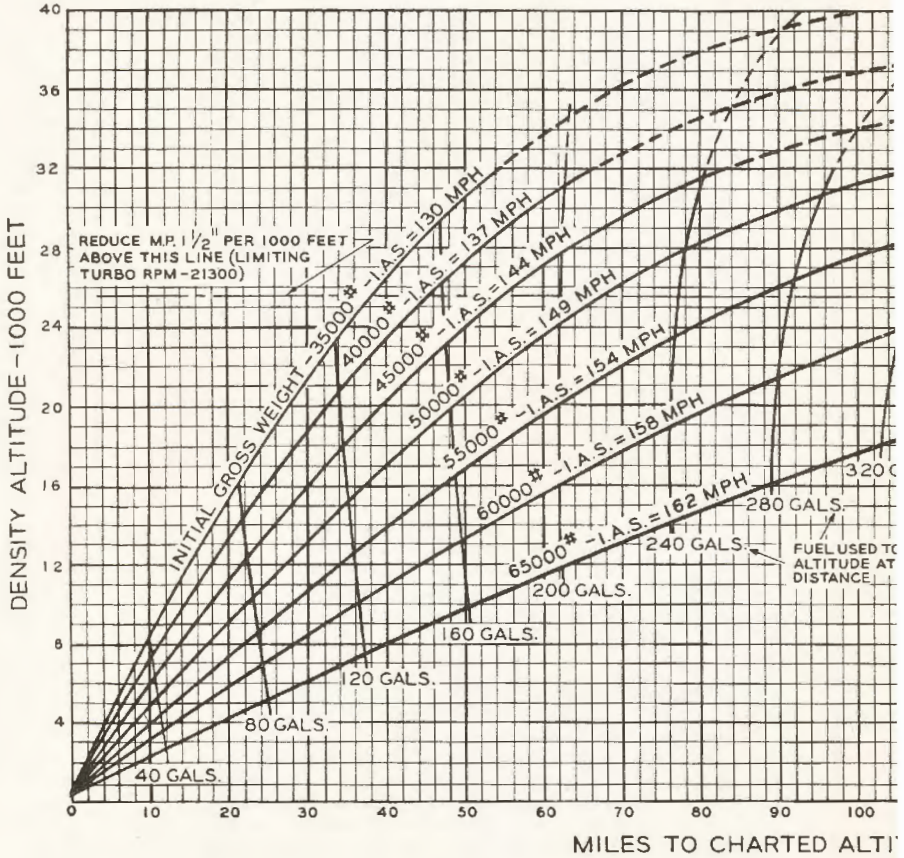

RESTRICTED

# MAXIMUM RANGE CLIMB CONTROL (B-24D)

BLADE TYPE NO. 6477A-0

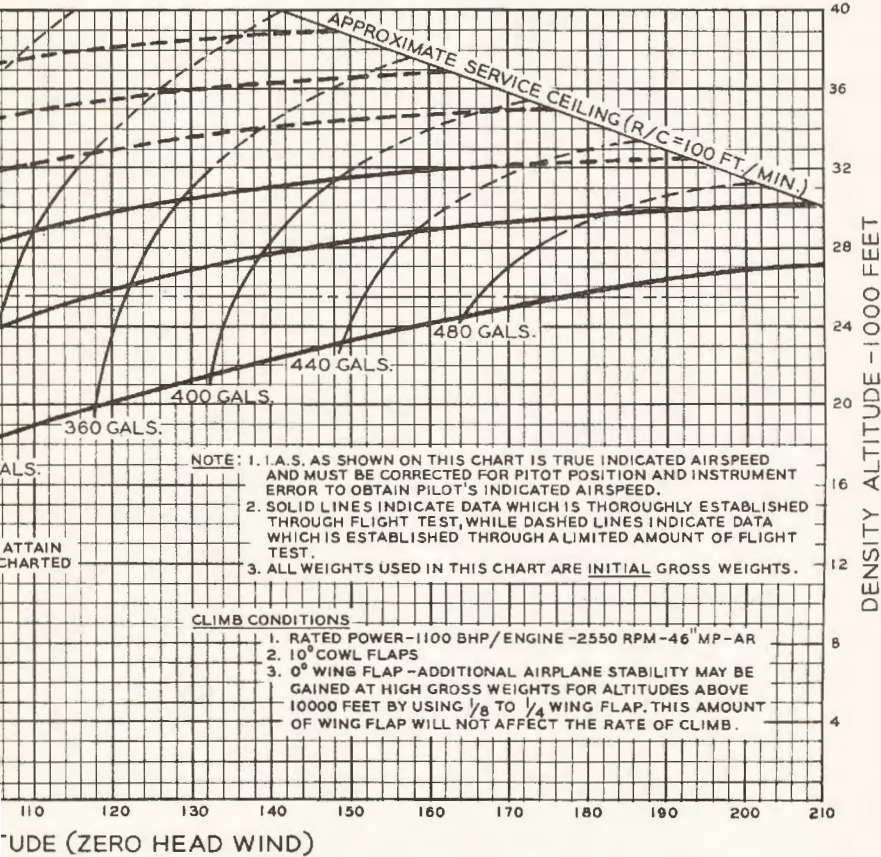



## THE CRUISE CONTROL CHART

Use of this chart allows quick and direct solution of problems involving various combinations of altitude, temperature, airspeed, gross weight, engine rpm, manifold pressure, and fuel consumption. It also gives approximate speeds for a maximum range operation. Pressure altitude: Pressure altitude is the altimeter reading when the barometric scale on the instrument is set to 29.92" Hg (1013 millibars). This scale setting should be used when converting pressure to density altitude.

### TO DETERMINE AIR SPEED FOR ANY DESIRED POWER AT ANY GROSS WEIGHT AND ANY ALTITUDE

Enter chart at outside air temperature (A) and follow arrows to pressure altitude (B) determining density altitude. Follow arrows across to desired or selected per cent power (C). Project down to gross weight at (D). Follow slope of weight variation lines to base line at (E). Project up to density altitude at (F). True airspeed and true indicated airspeed are read at (F). Fuel flow, rpm, and manifold pressure are found at (C).

#### EXAMPLE (illustrated on chart):

Find the airspeed corresponding to 70% BHP, 12,000 feet pressure altitude at 32°C free air temperature and 60,000 lbs. gross weight.

Entering chart at 32°C and 12,000 feet pressure altitude, a density altitude of 16,500 is determined. Follow 16,500 foot line horizontally to intersection with 70% BHP, and project this point vertically to line of 60,000 lbs. gross weight. Follow line parallel to weight correction to intersection with base line of 35,000 lbs. gross weight.

Project intersection to 16,500 feet and read 215 mph true airspeed and 166 mph true indicated airspeed. (Apply instrument and pitot position error correction to obtain pilot's corrected indicated airspeed reading for each individual airplane.)

### TO DETERMINE POWER REQUIRED FOR ANY DESIRED AIRSPEED AT ANY GROSS WEIGHT AND ANY ALTITUDE

This procedure is not illustrated on the chart, but is the reverse of that given above, except for steps (A) and (B), which are used for determining density altitude. In this case the desired airspeed is known at (F). Reverse the directions of the arrows, projecting down to (E) and following the slope of the weight variation lines to the gross weight at (D). Project up to the density altitude at (C). The power required (per cent of normal rated power at sea level), fuel flow, rpm, and manifold pressure are found at (C).

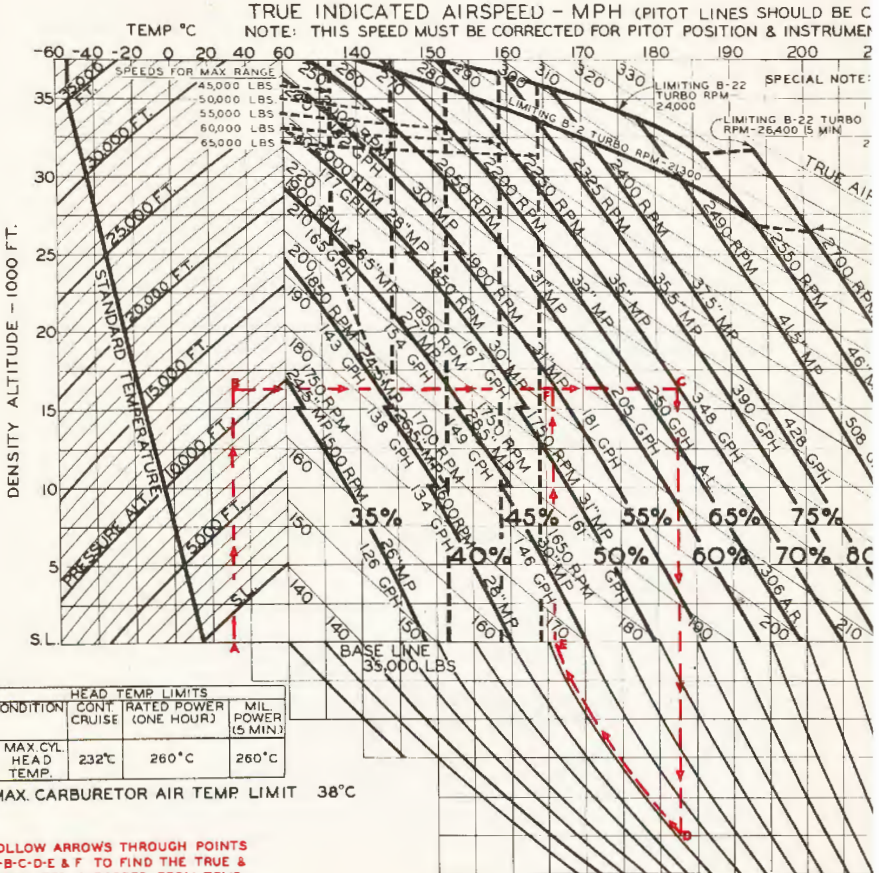

CONDITION	HEAD TEMP LIMITS		
	CONT. RATED POWER CRUISE (ONE HOUR)	MIL. POWER (5 MIN)	MIL. POWER (5 MIN)
MAX. CYL. HEAD TEMP.	232°C	260°C	260°C

MAX. CARBURETOR AIR TEMP LIMIT 38°C

FOLLOW ARROWS THROUGH POINTS A-B-C-D-E & F TO FIND THE TRUE & INDICATED AIRSPEED FROM TEMPERATURE, PRESSURE ALTITUDE, % POWER, AND WEIGHT.

TO OBTAIN G. W. AT ANY POINT DURING FLIGHT SUBTRACT WT. OF FUEL USED FROM INITIAL G. W.

NOTE: THE SPEEDS SHOWN WITH PROPELLER

RESTRICTED

# CRUISING CONTROL CHART MODELS B-24G,H & J NAVY PB4Y-1

(WITHOUT RADAR)  
R-1830-43 ENGINE  
(BENDIX-STROMBERG)  
CARBURETOR

AUTO RICH FOR 65% POWER AND ABOVE - AUTO LEAN BELOW 65%  
100% HP=4X1100 HP (NORMAL RATED)  
TAKE OFF - AUTO RICH, 2700/48.5"

### FOR USE IN CRUISING FLIGHT-

1. DETERMINE DENSITY ALTITUDE. SET MAN. PRESS. AND RPM TO CHARTED VALUES, AS REQUIRED, TO GIVE SPEED OR RANGE DESIRED.
2. IN HOT WEATHER INDICATED AIRSPEED WILL BE LOW, IN COLD, HIGH WHEN COMPARED TO CHARTED VALUES. CHANGE MAN. PRESS. AS REQUIRED TO OBTAIN CHARTED INDICATED AIRSPEED (THIS WILL ESTABLISH POWER EXACTLY. FUEL FLOW WILL THEREBY BE ESTABLISHED).
3. DO NOT INCREASE MAN PRESS. MORE THAN 2" ABOVE CHARTED VALUES WITHOUT RAISING RPM.
4. AFTER FINDING SPEED FOR BEST RANGE, USE WEIGHT CORRECTION IN DETERMINING POWER SETTING REQUIRED.
5. FOR STEADY CRUISING IT SHOULD NOT BE NECESSARY TO RE-SET POWER OFFENER THAN EACH HOUR. EVERY 3 HOURS WILL PROBABLY BE SATISFACTORY.
6. DO NOT EXCEED 32" MAN. PRESS. AND 2200 RPM FOR AUTO LEAN OR 35.5" MAN PRESS AND 2325 RPM FOR AUTO RICH FOR CONTINUOUS CRUISING.
7. AT AN ALTITUDE WHERE A CHANGE OF RPM IS SHOWN USE LOWER RPM.
8. WEIGHT OF FUEL TAKEN AS 5.89 LBS./GAL. (USING STANDARD TEMPERATURE CORRECTION)
9. FUEL FLOW VARIATION IS APPROX. 1% INCREASE FOR EACH 6000' INCREASE IN ALTITUDE. FUEL FLOWS GIVEN ON CHART ARE QUOTED FOR 12500' FOR POWERS RANGING FROM 60% TO MILITARY POWER. AT POWER CONDITIONS BELOW 60%, THE FUEL FLOW FIGURES ARE QUOTED FOR THE AVERAGE ALTITUDE, THROUGH THE ALTITUDE RANGES IN WHICH RPM IS HELD CONSTANT WITH THE GIVEN POWER CONDITION. FUEL FLOW FIGURES ARE FOR BENDIX STROMBERG CARBURETOR SETTINGS PD-12F2-14, PD-12F5-14.

CHECKED FREQUENTLY FOR LEAKS)  
T ERROR TO OBTAIN PILOT'S INDICATED AIR SPEED

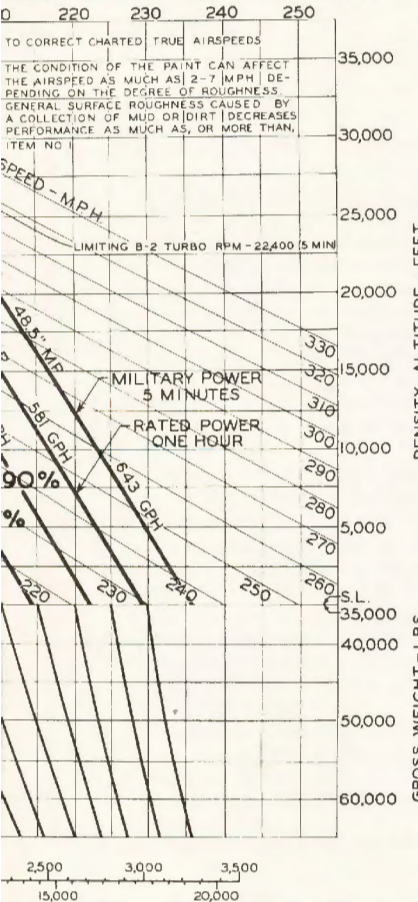

### 3-ENGINE CRUISING CONTROL CHART

The form on this chart is the same as that of the 4-engine cruise control chart and it is to be used in the same manner.

Though extensive tests of 3-engine performance were not made, data obtained indicate that the chart gives conservative values. It is recommended that the pilot check his individual airplane against this chart to determine how conservative the chart may be. The worst 3-engine condition (left outboard engine dead) as well as the best 3-engine condition (right inboard engine dead) should be checked.

The following facts should be kept in mind concerning 3-engine operation:

1. Airspeed will be less for a given amount of power from each engine, so care should be exercised lest the head temperatures become excessive.
2. Since engine temperatures are likely to become critical at high altitudes, a gradual descent to the lowest practical level is recommended.
3. The rpm and manifold pressure combinations which are used for normal operation should be satisfactory for the 3-engine condition; but it has been found that cooling is improved somewhat by using higher rpm and lower manifold pressure than those shown on the cruising control chart.

The additional dashed lines on this chart show the approximate minimum percent BHP which can be used for given gross weights. Corresponding airspeeds may be found by using the gross weight correction lines at the bottom of the chart in the regular manner.

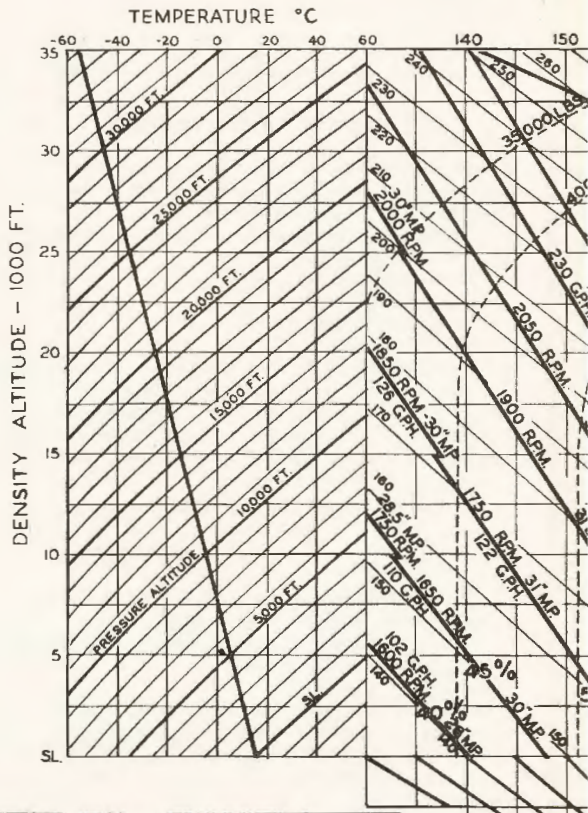

HEAD TEMPERATURE LIMITS			
CONDITION	CONTINUOUS CRUISING	RATED POWER	MILITARY POWER (5 MINUTES)
MAXIMUM CYLINDER HEAD TEMP.	232°C	232°C (CONTINUOUS) 260°C (ONE HOUR)	280°C

MAX. CARBURETOR AIR TEMP. LIMIT - 38°C

45,000  
GROSS WEIGHT

RESTRICTED

# 3-ENGINE CRUISING CONTROL CHART (B-24D)

TRUE INDICATED AIRSPEED - M.P.H.

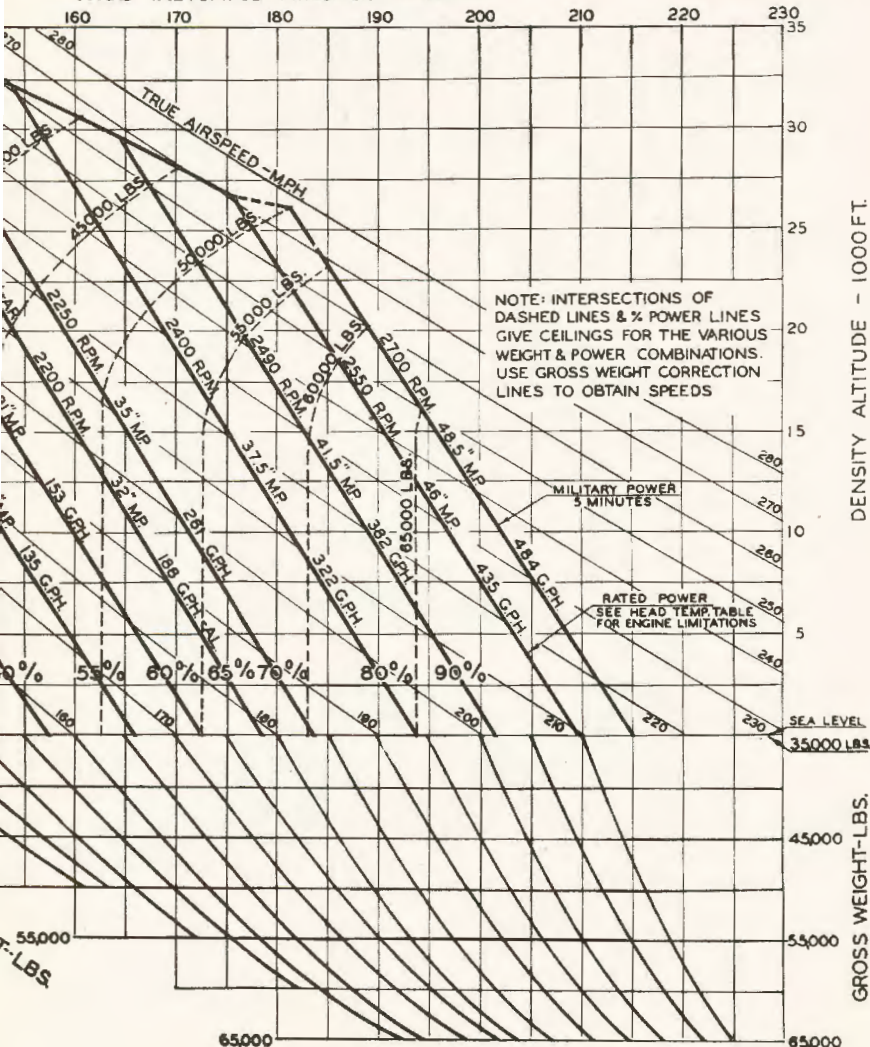

NOTE: INTERSECTIONS OF DASHED LINES & % POWER LINES GIVE CEILINGS FOR THE VARIOUS WEIGHT & POWER COMBINATIONS. USE GROSS WEIGHT CORRECTION LINES TO OBTAIN SPEEDS

MILITARY POWER 5 MINUTES

RATED POWER SEE HEAD TEMP. TABLE FOR ENGINE LIMITATIONS

DENSITY ALTITUDE - 1000 FT.

GROSS WEIGHT - LBS.

65,000

65,000

### MAXIMUM RANGE CONTROL CHART

Enter the chart with the desired gross weight, using the scale at the bottom of the chart. Project vertically, and at the proper altitude for each set of curves, read in turn:

1. Airspeed (to be corrected for instrument error).
2. Engine rpm.
3. Manifold pressure.
4. Brake horsepower.
5. Total fuel consumption.
6. Miles per gallon.

Having picked off the condition, set rpm and manifold pressure. Manifold pressure may have to be varied to give the desired airspeed. At charted speed and rpm the manifold pressure will be high in hot weather, low in cold weather, when compared to charted values. Manifold pressure should not be raised more than 2" above the charted value without raising rpm.

EXAMPLE: (Taken from maximum range control chart.)

Given:

Gross weight—45,000 lb.; Density altitude—15,000 feet.

Results:

True IAS—153 mph (apply pilot's instrument correction).

RPM — 1720; manifold pressure—28.3

BHP — 490 per engine (approx.) Fuel flow — 150 GPH (approx.)

Miles per gal. = 1.31 (approx.)

Notes:

1. For steady cruising it should not be necessary to re-set power more often than each hour. Every 3 hours will probably be satisfactory.

2. At low IAS, when flying on the autopilot, the pilot should pay close attention to the airplane in order to prevent inadvertent stalling when the airplane flies through sharp updrafts. However, in cases where maximum range and endurance demand low speeds, the airplane may be flown manually, returning to automatic control when the low speeds are no longer required.

3. At speeds other than those for maximum range or maximum endurance, the cruising control chart is used as a guide.

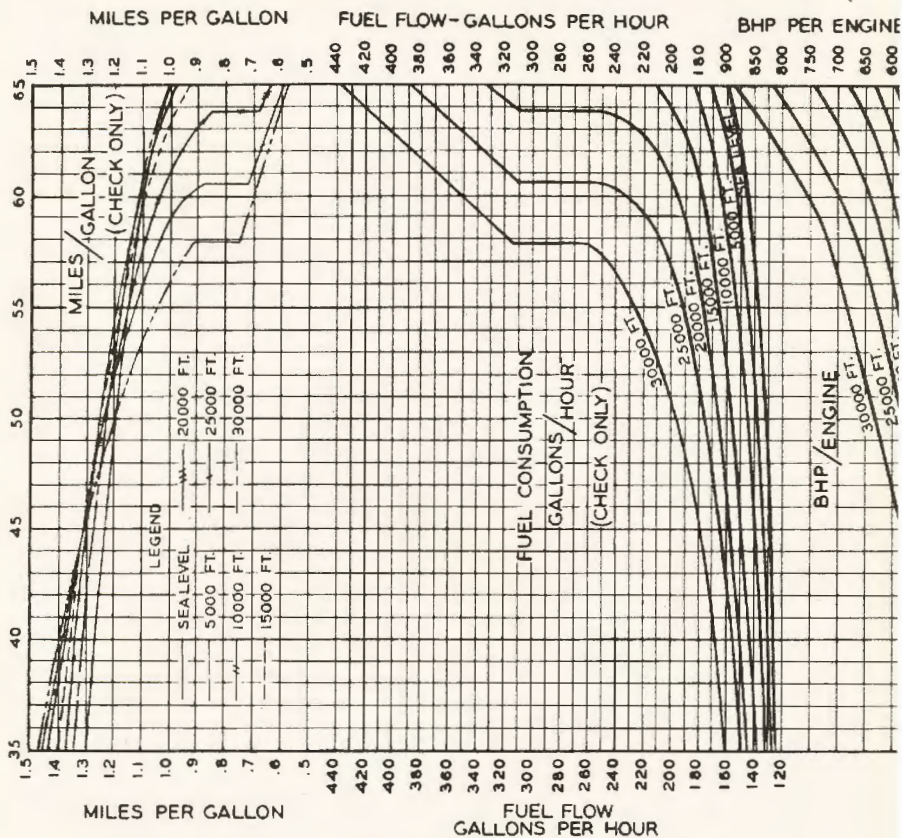

**PROCEDURE:**  
 ENTER CHART AT GIVEN GROSS WEIGHT. PROJECT VERTICALLY AND OBTAIN SETTING FOR TRUE INDICATED AIRSPEED, ENGINE RPM AND APPROX. MANI-

FOLD PRESSURE AT ANY GIVEN ALTITUDE.

**NOTE**

1. TRUE INDICATED AIRSPEED MUST BE CORRECTED TO PILOTS INDICATED.

2. FUEL CONSUMPTION AND MILES/GALLON OF FUEL ARE FOR CHECK PURPOSES ONLY. BHP IS APPROX. FOR A GIVEN ENGINE RPM AND MANIFOLD PRESSURE.

**RESTRICTED**



RESTRICTED

# MAXIMUM RANGE CONTROL CHART (B-24D)

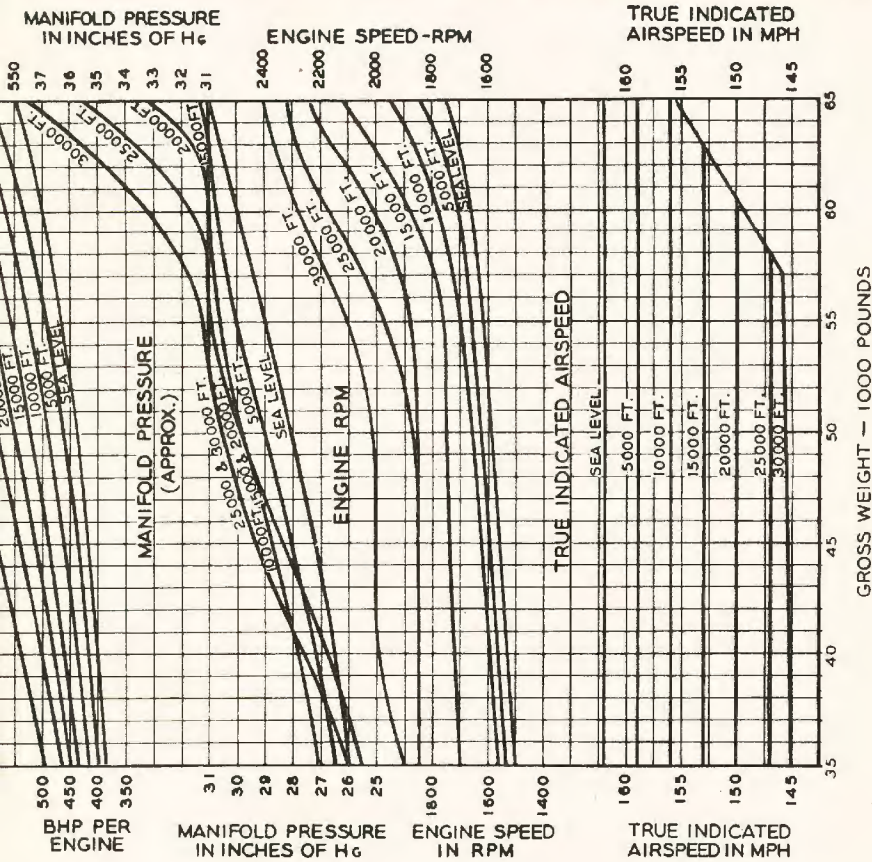

**SPECIAL NOTE: THE LOSS IN TRUE AIRSPEED DUE TO:**

1. THREE NOSE GUNS IS 2 MPH.
2. ROUGH PAINT IS 2-7 MPH DEPENDING ON THE DEGREE OF ROUGHNESS.
3. GENERAL SURFACE ROUGHNESS CAUSED BY A COLLECTION OF MUD OR DIRT IS AS MUCH AS ITEM NO. 2.

# QUESTIONS AND ANSWERS

1. Q. Is it proper to decrease rpm before manifold pressure?

A. No. Decrease manifold pressure first, then the rpm.

2. Q. What is the proper method to increase rpm and power settings?

A. Increase the rpm first, then the manifold pressure.

3. Q. When flying on instruments, name some of the conditions you may encounter that are not prevalent in contact flight?

A. Wing icing. Propeller icing. Pitot tube icing. Carburetor icing.

4. Q. How would you combat the conditions in question No. 3?

A. Operation of wing and tail group de-icer boots if conditions warrant it. Operation of propeller anti-icer system—should be put in operation before icing conditions exist. Turning on pitot tube heaters before flying on instruments. Closing the intercoolers and opening throttles when drop of manifold pressure or engine roughness occurs.

**Note:** Intercoolers should not be used for longer periods than necessary.

5. Q. Are there any restrictions on the use of the landing lights?

A. Yes. Due to the lack of rapid air circulation required to cool the lights, they should not be used longer than 3 minutes at a time while on the ground. Otherwise, light-bulb failure is likely. Use alternately while taxiing.

6. Q. When do you use the carburetor air filters?

A. When dusty air conditions are encountered on the ground or in the air.

7. Q. If you had hot gasoline (because of hot weather or a hot engine) with possible vapor lock trouble in flight, how would you remedy the situation?

A. By using the electric booster pump.

8. Q. In the event of a gasoline stoppage to an engine, what is the first indication on the instrument panel?

A. Fuel pressure drop.

9. Q. What is maximum allowable rpm and manifold pressure for using "AUTO-LEAN"?

A. 32" manifold pressure, 2200 rpm (grade 100 fuel) and 30" manifold pressure, 2100 rpm with grade 91 fuel.

10. Q. When do you use "FULL (EMERGENCY) RICH"?

A. At such time as the "AUTO-RICH" setting becomes faulty.

11. Q. If you were climbing at 35" manifold pressure and 2300 rpm and you reduced rpm to 2000, what would happen to the manifold pressure?

A. An increase of manifold pressure will occur with a resultant increase in BMEP.

12. Q. What is the desirable continuous operation head temperature?

A. 200° to 232°C. **Desirable 205°.**

13. Q. What is the maximum one-hour continuous operation head temperature?

A. Not to exceed 260°. Must be in "AUTO-RICH."

14. Q. At what rpm should Engine 3 be running to operate the hydraulic system normally?

A. Approximately 1000 rpm is required to operate the hydraulic system efficiently.

15. Q. If the propeller on Engine 3 is allowed

## RESTRICTED

to windmill, is the rpm sufficient to operate the hydraulic system?

A. The hydraulic pumps on Engine 3 will operate and supply pressure for the hydraulic system at all times when the engine is turning over. However, at low rpm the volume of oil supplied will be small; therefore, the action of any unit that is operated will be very slow.

16. Q. What should I do if a tire blew out on landing?

A. Put the nosewheel firmly on the ground. Use the engines on the side the tire is blown on, concentrating preferably on the outboard, and use sufficient brake on the good tire to keep the airplane rolling straight.

17. Q. What is the allowable range of brake accumulator pressures?

A. 850 to 1250 lb.

18. Q. What is the landing gear kick-out pressure?

A. Landing gear down—850 lb.

Landing gear up—1100 lb.

19. Q. Explain the different methods of lowering the flaps.

A. (a) Move the flap handle to "DOWN";

(b) If engine-driven hydraulic pump fails, or No. 3 engine is feathered, open emergency hydraulic (star) valve, turn on auxiliary hydraulic pump and place flap handle in "DOWN" position;

(c) Move the flap handle to "DOWN."

Close forward valve and open rear valve and hand-pump flaps down. Use this procedure when engine pump and auxiliary hydraulic pump are not working.

20. Q. How long will it take to bleed the shuttle valve for flap operation after the flaps have been lowered by means of the hand pump?

A. The time required will vary according to the temperature. At times it may take as long as 20 minutes. Normal operation would probably be 3 to 5 minutes. On cold days the aluminum cylinder will contract more than the steel piston and it may be necessary to tap the valve very lightly to jar the piston loose so that it will return to the normal operating position.

21. Q. Is it possible, under emergency conditions, to raise the flaps after they have been

lowered by means of the hand pump?

A. Yes. First, open both valves, located on top of the hand pump, to bleed off the pressure on the shuttle valve and allow the piston to return to the normal operating position.

Second, close the aft valve, leaving the forward valve open.

Third, place the flap selector valve in the "UP" position.

Fourth, operate the hand pump to supply hydraulic pressure through the open center system to operate the flaps.

22. Q. What should be done in case of a vapor lock in the hydraulic system?

A. This means there is air in the system. The selector valves should be operated back and forth, forcing the hydraulic pressure first one way and then the other, forcing the air into the reservoir until the system operates normally.

23. Q. What would happen if one accumulator was shot away?

A. One half of the braking action on each wheel would be lost. It would be impossible to operate the open center system until the broken line was sealed (or repaired).

24. Q. Why is the landing gear lever put in the "DOWN" position when parking the airplane?

A. With the landing gear lever in the "DOWN" position any increase of pressure in the system will be exerted on the down gear mechanism. This will hold the latches in the down position. An increase of pressure in the system could be caused by expansion of the fluid due to heat or changes in temperature.

25. Q. On the new airplanes, without the old de-boosters, the brake action is slow and then it grabs suddenly when it takes hold. What causes this?

A. The metering valve may not be properly adjusted and/or there may be dirt under the valve seat.

26. Q. What pressures are required to operate the bomb doors?

A. Bomb doors open—600 lb.

Bomb doors closed—1000 lb.

27. Q. Why does it take more pressure to close the bomb doors than it does to open them?

A. To compensate for the difference in force required on the top and bottom of the piston due to loss of area on the bottom of the piston on account of the connecting rod area.

28. Q. Why is the flap selector valve set to kick out at 450 lb. in the "DOWN" position and 750 lb. in the "UP" position?

A. To allow for the different operating forces required on the up and down operation, as well as to compensate for the loss of area on the bottom of the piston due to the connecting rod area.

29. Q. How can we determine when the air pressure in the accumulators is low?

A. When use of the brakes causes the accumulator pressure to drop rapidly, by chattering of the unloading valve when the accumulator is charged, or by frequent cutting in of the auxiliary hydraulic pump when this facility is in use.

30. Q. Can the air pressure in the accumulators be checked without removing the oil in the system?

A. No. The hydraulic fluid must be removed from the accumulator before the air pressure can be measured. If this were not done the gage would register the combined oil and air pressure.

31. Q. How often should the air pressure in the accumulators be checked?

A. During extreme cold conditions, the accumulators should be checked daily. Sluggish brake action usually indicates low air pressure in the accumulators.

32. Q. If a brake expander tube were ruptured, could the system be repaired so that the hydraulic fluid would not be lost when the brakes were operated?

A. Yes. By disconnecting the line at the brake valve and sealing the opening, or by breaking the line to the brake expander affected, and pinching or sealing the end.

33. Q. Is it possible to operate the flaps with accumulator pressure?

A. Yes. The procedure is as follows:

1. With the bomb doors closed, place the utility valve in the bomb door closed position.

2. Place the bombardier's bomb door

selector valve in the bomb door open position.

3. The pressure from the accumulator is then routed from the accumulator through the pressure line to the utility valve, out of the valve through the bomb door closed line to the operating cylinders at the bomb doors. Since the bomb doors are closed, the pressure backs up through the line to the bombardiers' bomb door selector valve. When the selector valve is in the bomb door open position, the bomb door closed line is the return, therefore, the pressure enters the open center system. By operating the flap or landing gear selector valve either unit will operate from the accumulator pressure provided there is sufficient pressure in the accumulator.

34. Q. Explain in detail all the methods of lowering the landing gear.

A. a. Lowering the gear through the regular method of hydraulic pressure created by No. 3 engine hydraulic pump.

b. Lowering the gear by hydraulic pressure created by the electric auxiliary system.

c. Lowering by hydraulic pressure created by the hand hydraulic pump on the copilot's side of the cockpit.

d. Lowering the gear manually by the hand crank mounted on the forward spar, requiring between 28 to 32 turns. **Caution:** This crank must be wound back to its original position before raising the gear hydraulically.

On late model airplanes the nosewheel can be extended manually in this manner. Pry open up-latch and depress drag strut to hold lock open, then disconnect lock mechanism with quick disconnect pin. Gear can be pushed overboard by lifting up and forward on the top of oleo cylinder. Gear will fall out and lock down.

35. Q. When the landing gear is lowered, under what condition is the selector valve first placed in the "UP" position, and why?

A. To insure a full supply of fluid on the up side of the piston and lines which will cushion the shock produced by dropping the main gear and relieve up locks of full weight of gear before they are unlatched. This is an advisable operation when lowering gear after flights of long duration. (Over 2 hours.)

## RESTRICTED

36. Q. Is it possible to lower the tailskid when the landing gear is lowered by emergency methods?

A. The tailskid is not lowered when the landing gear is lowered with the emergency hand crank. It is lowered by hydraulic pressure only.

37. Q. Is it necessary in emergency landing gear operation to unwind the cables on the drum before raising the gear?

A. Yes. If this is not done, the gear will not lock up.

38. Q. Why is it necessary to put the selector valve in the "DOWN" position when using emergency manual cable system for lowering the landing gear?

A. To relieve the hydraulic pressure on the up side of the operating cylinder, otherwise a hydraulic lock would be formed.

39. Q. Why must the utility valve be held open until the bomb doors are fully open?

A. Hydraulic pressure is supplied to the bomb door operating cylinders only when the valve is held in the open or closed position. When released, the utility valve returns to the neutral position which shuts off the hydraulic pressure.

40. Q. Is there a manual operation for lowering the flaps?

A. No.

41. Q. What should be done if the hydraulic suction line between the reservoir and No. 3 engine pump is broken?

A. Open the emergency hydraulic (star) valve and operate the auxiliary hydraulic pump to supply pressure for the open center system taking oil from the bottom of the reservoir. The check valve automatically shuts off the broken suction line.

42. Q. What should be done if the pressure line from engine No. 3 is broken?

A. Break the suction line to prevent loss of reserve oil and open the 3-way suction valve to take oil from the bottom of the reservoir. Open the emergency hydraulic star valve and turn on the auxiliary hydraulic pump to supply pressure through the open center system.

43. Q. Should the airplane be taxied with the inboard or outboard engines?

A. Taxiing with the outboard engines gives better control; therefore, they should be used. However, do not allow inboards to foul up.

44. Q. a. If, with the gear down, the throttle horn blows and the light does not come on, where would you look for the trouble?

b. Would you land with the horns blowing and no light?

A. a. The trouble usually occurs in the micro-switches sticking on the main landing gear. This trouble cannot be remedied from the cockpit. The light and the horns are on the same electric circuit. The micro-switch on the nosewheel locking mechanism can be checked and should be checked to see if it is the cause. If this switch is not at fault, there is nothing that can be done to remedy the matter while in the air.

b. Yes. If a visual check absolutely indicated that the gear was down and locked.

45. Q. When starting an engine how would you know if it is under-primed? Over-primed?

A. Usually an under-primed engine fails to give an indication of wanting to start or there may be a weak explosion occasionally while the engine is being turned over by the starter. An over-primed engine is usually one where the mixture is so rich and the explosions are so weak they will not keep the engine running; also white vapor coming out of the exhaust pipe is an indication, under some conditions, of an over-primed engine. **Note:** It is practically impossible to write all the causes or combinations of causes and remedies for the above. It is up to the pilot to learn the symptoms himself and apply the proper remedy.

46. Q. With a flooded engine, where would you place the throttle while starting?

A. Place the throttle in the open position.

47. Q. What is liable to happen if you take off in "AUTO-LEAN"?

A. If the carburetor mixture is in proper adjustment, possibly nothing would happen because the fuel mixture curve in "AUTO-LEAN" is almost the same as "AUTO-RICH" at maximum power output. However, the danger is that the fuel mixture curve drops rapidly to a leaner mixture upon slight reduction of power. This

will cause detonation and possible engine failure.

48. Q. How would you determine whether the artificial horizon air screen is dirty?

A. By observing the speed with which the instrument erects when the engine driving the instrument vacuum pump is started.

49. Q. Would you cage and set your artificial horizon in a climbing turn? Why?

A. No. Because it would give erroneous readings and it would take several minutes for it to seek its proper position again.

50. Q. What are the maximum allowable precession limits on the directional gyro?

A. Precession shall not exceed  $3^\circ$  in either direction for any 15-minute period on any heading, except that a maximum of  $5^\circ$  precession is permitted on one heading when the total precession on 4 headings  $90^\circ$  apart from each other does not exceed  $12^\circ$  and the precession does not exceed  $3^\circ$  on any of the other 3 headings.

51. Q. What is a spilled gyro instrument and how is this accomplished?

A. A spilled gyro is a gyro which has exceeded its stop limits. Occurs during aerobatics or banks steeper than the stop limits of the instrument.

52. Q. How do you know when the engines are warm enough to taxi?

A. When the oil pressure has returned to its operating pressure, approximately 80-100 lb.; when the oil temperature reaches a minimum of  $40^\circ\text{C}$ ; when the head temperature is  $120^\circ\text{C}$ .

53. Q. Is there any reason why you should not taxi through mud with the wing flaps down?

A. Yes. You are likely to throw mud into the exposed flap tracks, thus impairing the operation of the flaps.

54. Q. When taking a bearing on a radio station with the loop antenna using the aural null, does the needle always point toward the station?

A. No. It will point either at the station or exactly  $180^\circ$  away from the station.

55. Q. What receiver and antenna combination would you use when flying in an overcast

where reception is poor?

A. The radio compass receiver and the loop antenna, with the radio compass adjusted  $90^\circ$  to the station; or rotate the loop until you get maximum signal strength.

56. Q. How do you tune the radio compass to a station?

A. With the radio receiver on the antenna setting identify the desired station and get a clear signal by use of maximum tuning indicator, then put the receiver on the compass setting.

57. Q. Does the radio compass, properly tuned to a station, always lead you straight to the station?

A. It will if you have absolutely no drift. However, with a drift condition, you will fly in an arc reaching your station.

58. Q. How many radio receivers is the B-24 airplane equipped with which will receive radio range signals?

A. Three receivers: the command set, the radio compass set, and the liaison set.

59. Q. In the event No. 4 engine was on fire in flight, explain what you would do in sequence.

A. Turn off the electric booster pump, turn the gasoline selector valve supplying fuel to this engine to the "OFF" position, close the cowl flaps, feather the engine and put mixture in "IDLE CUT-OFF" when fuel in lines has been used and fuel pressure has dropped to zero. In event the plane is equipped with a Lux fire extinguisher, turn its selector handle to No. 4 engine and operate the system. In this case, close cowl flaps to confine  $\text{CO}_2$  in nacelle.

60. Q. Referring to question No. 59, is the condition the same on No. 1, 2, and 3 engines? If not, explain.

A. The procedure would be the same, with the exception of No. 1 or No. 2. Check which engine was driving the gyro instruments. Also check No. 3 engine before coming in to land and be sure the auxiliary electric hydraulic system is in operation.

61. Q. How would you reduce the BMEP on an engine?

A. By increasing the rpm or reducing the manifold pressure.

## RESTRICTED

62. Q. If you knew the nosewheel was not lined up straight before landing, what would you do?

A. This is generally one indication that the shimmy damper is not working. On accumulator-type damper, align wheel with shimmy damper locks. On Houdaille shimmy damper where no lock is available, make a nose high landing as you would do for a damaged nose-wheel.

63. Q. In the event No. 2 engine gasoline cells became faulty, how would you bypass these cells and keep No. 2 engine running? Does this procedure hold true on any of the other engines?

A. Turn No. 2 engine selector valve to crossfeed to engine. Turn selector valve of fullest tank to tank to engine and crossfeed. Turn on fuel booster pump of fullest tank. This holds true on all engines.

64. Q. What precautions would you take before transferring fuel from the bomb bay tanks?

A. Because of possible gas fumes prevalent during this operation, see that all the radio receivers and transmitters are off and permit no smoking. Unless necessary, see that the fuel booster pumps are off. Operation of any electrical unit which might create a spark should be avoided until the operation is completed, and any cabin heater in operation should be off. Crack bomb doors 6 to 8 inches and place observer in bomb bay to note any possible leakage and any abnormal function during transfer. Do not remove bomb bay tank caps while transfer pump is in operation.

65. Which engine has the instrument vacuum pump on and which has the wing boot pump?

A. No. 1 and 2 engines drive the vacuum pumps actuating the instruments and wing boots. When the selector valve has No. 1 engine driving the instruments, No. 2 engine is automatically driving the wing boots, or vice-versa.

66. Q. What is your overshoot procedure?

A. Procedure: First, apply power. Second, reduce flap setting to  $\frac{1}{2}$  or to 20°. Third, raise the gear. The cowl flaps should be adjusted immediately after power is applied. The flaps should be completely raised when safe

to do so after the gear is up.

67. Q. How do you ascertain the main gear latch is locked on the visual inspection?

A. By seeing that the yellow latch locks are in the lower position in the slot. This can only be seen from waist gun windows when flaps are in the upper position.

68. Q. If you were taking off into a low ceiling where you would immediately go on instruments, what precautionary measures would you take before takeoff?

A. Ascertain that all gyro instruments are working properly. Taxi, making S turns to determine that bank and turn instrument is operating. Check de-icer boots for operation and propeller anti-icer fluid operation. Also, immediately off the ground, turn on pitot heaters. The pitot tube heaters should be checked by feel on the ground and then turned off because continual use on ground may damage element.

69. Q. What will result from excessive cowl flap opening?

A. Will result in tail buffeting and lazy aileron action. Flap opening of from 10° to 20° is the range where usually the highest buffeting condition occurs. If permissible, a wide-open cowl flap setting is better if required for engine cooling rather than a flap setting in the range between 10° and 20°. However, the wide-open cowl flap setting will cut down the performance of the aircraft considerably.

70. Q. If oil dilution is over-used, what is the danger?

A. The over-use of this system dilutes the oil to such a light viscosity that the high gasoline content in the oil allows the gas fumes to come out the engine breather and into the combustion chambers, constituting a fire hazard.

71. Q. What would you do if your airspeed indicator failed because of stoppage in the passage?

A. Ask the bombardier to call airspeed over the interphone.

72. Q. In the event No. 3 engine was feathered and you were coming in for a landing, what would you do?

A. Be sure that the electric auxiliary

hydraulic system was functioning and in operation, and open star valve to lower the gear and flaps.

73. Q. Is it necessary to use the fuel booster pumps after takeoff?

A. After takeoff, when 1000 feet above the ground, they are not required again until an altitude of 10,000 feet has been reached or when a drop of 2 lb. on the fuel pressure occurs.

74. Q. What is likely to happen if an engine backfires with the turbo waste gate closed?

A. It is liable to damage the waste gate turbo mechanism and exhaust system.

75. Q. What will happen if you take off or land with the wing de-icer boots inflated?

A. It will disturb the air flow over the wings, causing the aircraft to act in an abnormal way and increase the stalling speed.

76. Q. How do you approach your cruising altitude, from below or from the top?

A. From about 500 feet on top.

77. Q. What is meant by flying on the step?

A. By flying the airplane in a minimum-angle-of-attack attitude.

78. Q. If you set your turbos for 47" manifold pressure for takeoff at San Diego, would this same setting give you 47" for takeoff at Salt Lake City, Utah? If not, why?

A. No. Because of higher altitude at Salt Lake City, if the turbo lever were set at the same position as San Diego, you would have about 4½" higher manifold pressure at Salt Lake City.

79. Q. What is the trend of the mechanically driven internal supercharger in regard to manifold pressure drop or increase in relation to increase in altitude?

A. The trend is for the manifold pressure to decrease with increase of altitude.

80. Q. Is the exhaust-driven turbo-supercharger's trend in regard to increase in altitude the same as the engine-driven supercharger?

A. No. The turbo-supercharger increases manifold pressure with increase in altitude because of the density of the air decreasing with altitude, allowing the exhaust gases to escape more readily through the bucket wheel.

81. Q. What would the result be if you took off with the intercoolers closed?

A. Probably detonation.

82. Q. What is the purpose of the intercoolers?

A. To cool the air compressed through the turbo-supercharger.

83. Q. When would you close the intercooler shutters?

A. When flying in icing conditions to control carburetor air temperature.

84. Q. How much load will the tailskid support?

A. A very small amount. Heavy loads on the tailskid should at all times be avoided. Care must be taken any time the airplane is being towed backwards that the tailskid never touches the ground.

85. Q. In the event you encountered highly turbulent rough air conditions how would you fly the airplane?

A. Slow the airplane to 150 mph and use a partial wing flap setting for additional lift and stability. The landing gear may be lowered to avoid too great a decrease in power.

86. Q. In slow flight, such as traffic pattern flying, what is the best wing flap setting? Why?

A. 10°. This increases stability of the airplane and also lowers the stalling speed.

87. Q. What is likely to occur if excessive airspeed is allowed with a full flap setting?

A. Possible springing of the flap tracks or other structural failure would result. The bleed-back valve which is supposed to allow the flaps to retract at excessive airspeeds would not allow the flaps to retract soon enough if the airplane was suddenly allowed to attain an excessive airspeed.

88. Q. How tight do you have your copilot sub the throttles on takeoff?

A. Tight enough to hold the throttles in position but not so tight that throttles cannot readily be moved in case of emergency.

89. Q. When spinning the turbo bucket wheel by hand, what do you look for?

A. Warped bucket wheel, proper bucket wheel clearance, noisy bearings, and freedom of movement.

90. Q. Leaking fluid on the outside of landing gear wheel indicates what?

A. Indicates a leak in brake line or frac-



## RESTRICTED

tured brake expander bladder.

91. Q. If a wheel wobbles during taxiing, what's wrong?

A. Probably a cracked wheel flange.

92. Q. If you smelled burning rubber while retracting the landing gear, what is the probable cause?

A. Nosewheel not lined straight fore and aft, allowing it to rub on structural members of the airplane during retraction.

93. Q. What is the function of the master bar switch?

A. It cuts all the magnetos off as well as all electric current unless the generators or auxiliary power unit (APU) are in operation. If they are in operation, you will still have electric power but no magnetos.

94. Q. When are the engines ready to run up?

A. When the head temperature is 150°C, oil pressure within the operating limit and the oil temperature above 40°C.

95. Q. What is the maximum allowable mag- neto rpm drop or engine run-up?

A. 100 rpm if the engine is smooth.

96. Q. What is the MAC or mean aero- dynamic chord?

A. MAC is the average chord or width of a tapered wing.

97. Q. Is there a rule-of-thumb method by which the CG of an airplane can be determined without the use of the load adjuster?

A. There is no rule-of-thumb method accurate enough to warrant its use.

98. Q. What is the root chord of a wing?

A. The root chord is the distance from the leading edge to the trailing edge at the largest section of a tapered wing.

99. Q. What percent of the MAC is the most forward limit of the CG?

23%.

100. Q. What percent of the MAC is the most aft limit of the CG?

A. 23%.

101. Q. How was the CG range determined?

A. The forward and aft CG limit in percent of the MAC from the leading edge of the MAC is determined by means of flight tests.

102. Q. What is the effect of overloading an airplane?

A. Overloading causes higher stalling speeds, results in lowering of the airplane structural safety factors, lowers the angle and rate of climb, decreases ceiling, increases fuel consumption and lowers the general tire factor of safety.

103. Q. What happens when the CG is too far aft?

A. If the CG is too far aft it creates un- stable conditions, thereby increasing the tend- ency to stall. It definitely limits low power and might very easily affect long-range opti- mum speed adversely. In the extreme condition it may even cause a stall during an up-gust.

104. Q. What happens when the CG is too far forward?

A. Fuel consumption is increased, great- er power is required for the same speed and there is an increased tendency to oscillate as well as to increase dive beyond control. It may cause a critical condition during flap operation. It definitely increases the difficulty in getting the nose up during landing.

105. Q. What is meant by moment?

A. Moment is the turning effect exerted by a force or weight about a fulcrum point and is equal to the weight times the distance from the fulcrum to the weight.

106. Q. If on the final approach with thro- tles back you accidentally put the propellers in low rpm, what would happen when you ap- plied power?

A. Absence of usual propeller noise, very slow response in airspeed increase be- cause of absence of power, much lower rpm than customary. This condition can prove dis- astrous if the airplane is being dragged in on the approach or in the event of an overshoot. Do not do it!

## Index

AC Power Failure.....	193	Final Approach .....	87
After-takeoff Checklist .....	60	for Autopilot .....	163
Airspeed Limitations .....	74	Go-around .....	93
Anti-icing Equipment .....	151	Starting .....	44
Armament, Description .....	23	Unfeathering .....	198
Autopilot .....	161	Climbing .....	65
Auxiliary Power Unit.....	131	Control Chart .....	253
B-24N .....	27	Decreasing Atmospheric Pressure in.....	67
Bailout .....	210	Decreasing Temperature in.....	67
Balance, Principles of .....	240	Engine Heat in .....	66
Banks, Angle and Speed in.....	78	Close-in Approach .....	98
Before-landing Checklist .....	84	Cockpit, Illustrations of.....	26
Before-starting Checklist .....	39	Controls, Location of.....	26
Before-takeoff Checklist .....	54	Copilot, Duties of.....	13
Before-taxiing Checklist .....	46	Crosswind Takeoff .....	62
Belly Landing .....	99	Cruise Control Chart.....	254
Blowouts .....	103	3-engine .....	256
Bomb Bay Doors, Hydraulic Control.....	129	Cruising .....	71
Emergency Operation .....	205	Night .....	226
Bomb Release, Emergency.....	205	Davis Wing, Description.....	23
Bombardier, Duties of .....	16	Defrosters .....	151
Brake Mean Effective Pressure.....	117	De-icing Equipment .....	151
Brakes, Hydraulic Control.....	130	Description, General .....	22
Carburetors, Description .....	113	Detonation .....	120
Icing .....	113	Dimensions .....	20
Checklist, After-takeoff .....	60	Ditching .....	213
Before-landing .....	84	Dives .....	79
Before-starting .....	39	Electrical System .....	131
Before-takeoff .....	54	Failures .....	208
Before taxiing .....	46	Fires .....	219
End of Landing Roll.....	94	Electronic Turbo Control.....	105
Feathering .....	197		

**RESTRICTED**

Emergency Procedures	
AC Power Failure.....	193
Blowouts.....	103
Bomb Bay Doors, Emergency Operation.....	205
Bomb Release, Emergency.....	205
Ditching.....	213
Electrical System Failure.....	208
Engine Failure.....	120
Feathering, Emergency.....	196
Fires.....	217
Inverter Failure.....	193
Landings, Emergency.....	99
Landing Gear Failures.....	200
Radio Failure.....	227
Wing Flaps, Emergency Operation.....	205
Engineer, Duties.....	17
Engines, Description.....	105
Faulty Operation.....	121
Fires.....	217
Run-up.....	53
Engine Failure, Causes of.....	120
in Landings.....	191
in Level Flight.....	189
in Traffic.....	191
on Takeoff.....	187
With De-icers on.....	189
Exterior Lights.....	224
Feathering, Checklist.....	196
Emergency.....	196
Questions and Answers.....	199
Final Approach Checklist.....	87
Final Approach, at Night.....	227
Fires.....	217
Fire Extinguisher Systems.....	219
Flares.....	221
Flight Characteristics.....	73
Flight Control Charts.....	248
Flight Restrictions.....	74
Formation Flying.....	231
Formation Stick.....	168
Frequency Meter.....	177
Fuel System.....	135
Fuel Transfer.....	137
Go-around.....	93
With 3 Engines.....	193
Gunners, Duties of.....	19
Gyro Flux Gate Compass.....	174
Hand Pump, Hydraulic.....	126
Heating Systems.....	147
High Performance Takeoff.....	63
Takeoff Chart.....	250
Hydraulic Pressure Settings.....	127
Hydraulic System.....	123
Failure of.....	206
Icing on Aircraft.....	151
Inspection, External.....	30
Internal.....	36
Instrument Lights, Description.....	224
Intercooler Shutters, Function of.....	109
Interphone Equipment.....	181
Inverter Failure.....	193
Landing Gear, Description.....	22
Emergency Lowering.....	200
Hydraulic Control.....	127
Landing Table.....	82
Landings, Belly.....	99
Crosswind.....	89
Errors in.....	88
Descent for.....	80
Forced.....	99
Night.....	227
No-flap.....	101
Short-field.....	96
With Damaged Nosewheel.....	102
With Dead Engines.....	191
With One Main Wheel.....	102
Without Brakes.....	102
Leveling Off.....	68
Lights, Exterior.....	224
Instrument Panel.....	224
Limitations, Airspeed.....	74
Load Adjuster.....	243
Load Factor in Banks.....	78
Low Visibility Approach.....	98
Maximum Range Control Chart.....	259
Mean Aerodynamic Chord.....	241
Mixture Controls, Description.....	113
Navigator, Duties of.....	13
Night Flying.....	222
Nose Gear Failures.....	202
Oil Dilution.....	135

Oil System .....	133
Overspeeding Turbos .....	113
Oxygen Systems .....	154
Parking .....	94
Pilot's Controls, Illustration of .....	26
Pilot's Direction Indicator .....	167
Power Changes, Sequence of .....	117
Power Increase, Sequence for .....	118
Power-off Approach .....	96
Power Plant .....	105
Power Ratings, Definitions .....	116
Power Reduction, Sequence for .....	119
Power Settings, Climbing .....	66
Cruising .....	71
Effects of .....	249
Limits of .....	116
3-engine Cruising .....	256
Priming .....	45
Prohibited Maneuvers .....	73
Propellers, Feathering .....	196
Runway .....	194
Synchronizing .....	69
Unfeathering .....	198
Pumps, Hydraulic .....	123
Questions and Answers, General .....	261
Quick Descent for Landing .....	81
Radio Equipment .....	176
Compass .....	183
Failure, at Night .....	227
Radio Operator, Duties of .....	17
Recovery From Stalls .....	75
Running Takeoff .....	61
Securing Airplane .....	95

**RESTRICTED**

Shimmy Damper .....	130
Failure of .....	130
Signal Equipment .....	221
Specifications .....	20
Stalling Speeds, Table .....	75
Stalls .....	74
in Turns .....	77
Starting .....	44
Superchargers in Cruising .....	72
Synchronizing Propellers .....	69
Takeoff .....	58
Crosswind .....	62
High-performance .....	63
Night .....	225
Running .....	61
Taxiing .....	48
Crosswind .....	91
Night .....	225
Tire Trouble .....	103
Traffic, Engine Failure in .....	191
Trimming .....	70
Turbo-Superchargers .....	105
Electronic Control .....	105
Overspeeding .....	113
Turns .....	76
in Taxiing .....	50
With Dead Engines .....	190
Unfeathering Checklist .....	198
Ventilation System .....	160
Vision at Night .....	230
Weight and Balance .....	240
Wing Flaps, Description .....	24
Emergency Operation .....	205
Hydraulic Control .....	129